

Adtran

Quick Start Guide

BSAP 6040

4x4 AX Dual-band AP

March 2023
61700972F1-13D

P/N: 1700972F1

Overview



WARNING!

Read all warning, cautions, notes and installation instructions before installing or servicing this equipments.

This quick start describes how to install and access ADTRAN's Bluesocket 6040 access point (BSAP), a Wi-Fi 6 (802.11ax) 4x4 indoor AP designed to provide enterprise-grade performance within high-density wireless environments. This robust AP simultaneously supports four transmit and four receive streams with data rates up to 3.5 Gbps (2.4 Gbps for 5 GHz and 1.1 Gbps for 2.4 GHz) using four internal MU-MIMO antennas with up to 5 dBi peak gain, and supports zero-touch provisioning using ADTRAN's virtual wireless local area network (vWLAN) cloud-management application. The BSAP 6040 is fully functional with 802.3at Power over Ethernet (PoE+), WPA3 encryption and Wireless Intrusion Detection (W-IDS) for added security, support for the traditional DynamicRF, Neighbor Discovery, Layer 7 device fingerprinting features and the new multi-user MIMO (MU-MIMO), orthogonal frequency-division multiple access (OFDMA), basic service set (BSS) coloring, advanced 1024-QAM, and target wake time (TWT) features for Wi-Fi 6.

- ["Installing the BSAP 6040"](#) on page 2
- ["Supplying Power to the BSAP 6040"](#) on page 5
- ["Connecting to the BSAP 6040"](#) on page 5
- ["Managing the BSAP 6040"](#) on page 6
- ["BSAP 6040 LED Descriptions"](#) on page 7
- ["Product Specifications"](#) on page 8

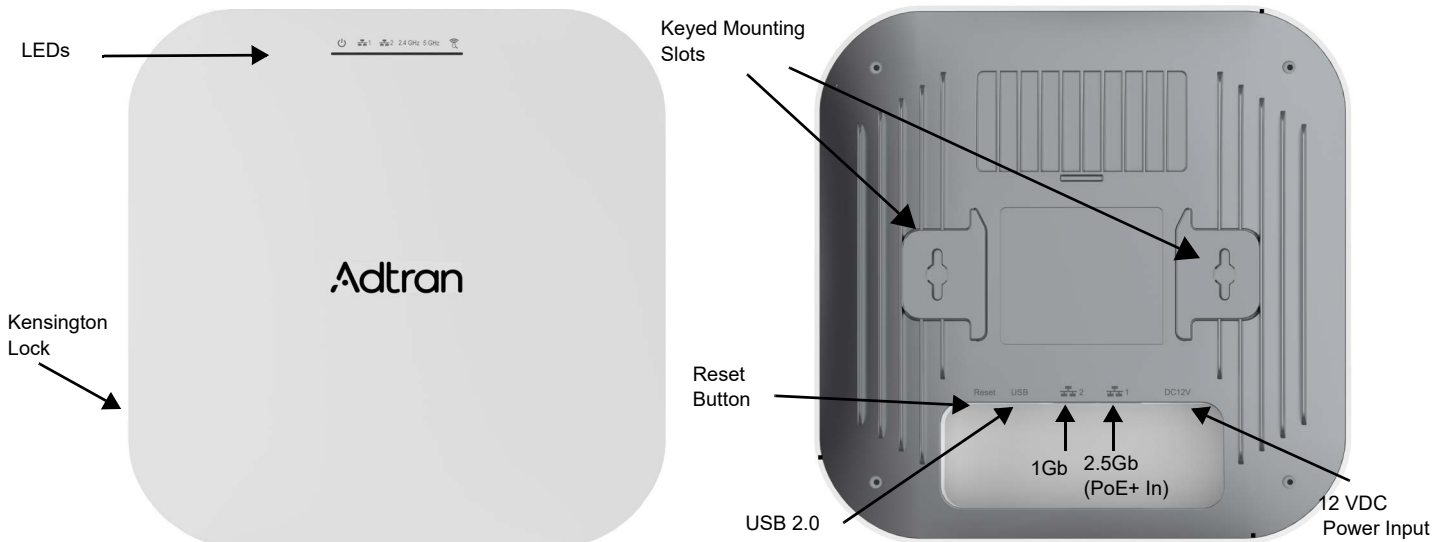

Figure 1. BSAP 6040



WARNING!

WARNING indicates a hazard which, if not avoided, could result in death, injury or serious property damage.



CAUTION!

CAUTION indicates a hazard which, if not avoided, could result in service interruption, damage to the equipment, or minor property damage.



NOTE

NOTES inform the user of additional, but important, information or features.

Installing the BSAP 6040



NOTE

Refer to the national, state and local electrical codes for the requirements for power, grounding, wiring, and installation methods.

Package Contents

- ADTRAN's BSAP 6040
- One wall/ceiling mounting hardware kit
 - ◆ Two plastic anchors (0.24" diameter (6 mm) x 0.99" long (25 mm)) and mounting screws (0.12" diameter (3 mm) x 0.63" long (16 mm)) for solid walls (such as concrete)
 - ◆ Two metal anchors (0.28" diameter (7mm) x 1.68" long (42.8 mm)) and mounting screws (0.14" diameter (3.5 mm) x 1.26" long (32 mm)) for hollow walls/ceilings (such as drywall, sheetrock, or ceiling tiles)
- Two T-rail mounting brackets (9/16" (14.29 mm) and 15/16" (23.81mm)) for recessed drop ceilings
- One pole mounting base with hardware (one hose strap and pole mounting bracket)
- Quick Start Guide



CAUTION!

The ADTRAN BSAP 6040 is intended for indoor use only. Ethernet, PoE+ cables, and attached equipment are intended for use within the same building with equipotential bonding, and not intended to be placed in separate buildings or structures. Failure to deploy as described could result in permanent damage from lightning or other electrical events and voids the warranty.

Prior to Installation

Before installing the equipment, inspect the AP. If damage has occurred during shipping, file a claim with the carrier, and then contact ADTRAN Customer Support. For more information, refer to the product warranty available online at https://adtran/wp_support_warranty.

Mounting the BSAP 6040 to a Ceiling or Wall

Position the BSAP for maximum throughput and range between other APs and wireless client devices. Complete these instructions and refer to [Figure 2](#) to mount the BSAP 6040 on an interior ceiling or wall using the enclosed ceiling/wall mounting kit:

1. Select the appropriate anchor and screw combination for the material in which you will be installing the BSAP (plastic anchors for solid walls (such as concrete), and metal anchors for hollow walls/ceilings (such as drywall, sheetrock, or ceiling tiles).
2. If using plastic anchors, using a 0.25-inch (6.35 mm) drill bit, drill two holes in the ceiling or wall 2.75 inch (69.85 mm) apart and drill an appropriate size hole (0.24" diameter (6 mm)) into each of the markings. The metal anchors are no-drill anchors and do not require a drilled hole.
3. Insert the appropriate anchors into each of the drilled holes. If using metal anchors, tap the anchors into the mounting surface in the marked location(s) until the threads are secure, and then screw them in until they are flush with the surface.
4. Drive the provided mounting screws into the anchors leaving enough of the screws exposed to ensure that the screws can be inserted into the keyed slots in the bottom of the unit.
5. Insert the screws into the keyed slots on the bottom of the BSAP and slide the BSAP forward (or backward) on the screws to securely mount it in place.
6. Optionally, protect your BSAP with a Kensington cable lock (not provided) in the security slot.

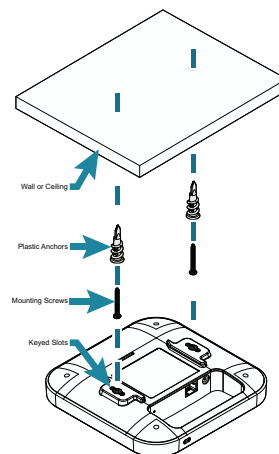

Figure 2. BSAP 6040 Ceiling or Wall Mount

Mounting the BSAP 6040 to a Dropped Ceiling

Position the BSAP 6040 for maximum throughput and range between other APs and wireless client devices. The BSAP 6040 ships with plastic flush and recessed ceiling mounting brackets (T-rail kits) to mount the BSAP on the ceiling tile separators of standard and recessed dropped ceilings. Complete these instructions and refer to [Figure 3](#) to mount the BSAP 6040 to a dropped ceiling:

1. Attach the T-Rail mounting bracket to the back of the BSAP by sliding the bracket into the recessed area behind the keyed slots until locked in place (refer to [Figure 3](#) on page 3).

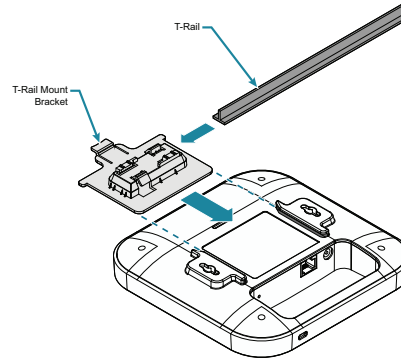

Figure 3. BSAP Ceiling Mount Brackets

2. Once the mounting bracket is attached to the BSAP, align the mounting bracket at a slight angle to the T-rail. Slide the long bracket tabs onto the T-rail and rotate slightly until the flexible bracket tabs snap into place.

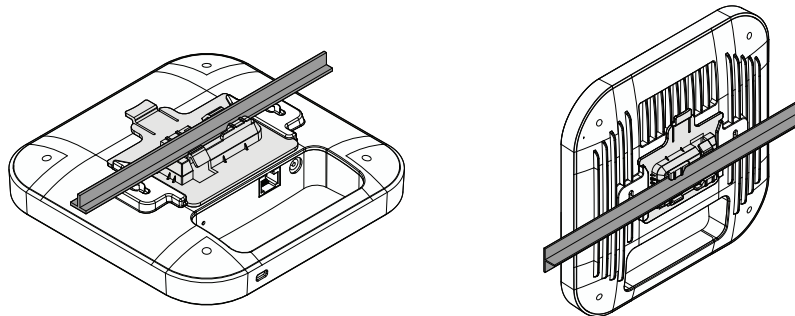

Figure 4. BSAP Dropped Ceiling Mount

3. Optionally protect your BSAP with a Kensington cable lock (not provided) inserted in the security slot.

Mounting the BSAP 6040 to a Pole

The BSAP 6040 also ships with a pole mount base and hose strap to mount the AP to a vertical or horizontal pole. BSAPs should be positioned for maximum throughput and range between other APs and wireless client devices.

Attaching the Pole Mounting Bracket to the BSAP:

1. Attach the pole mounting bracket to the back of the BSAP by sliding the bracket into the recessed area behind the keyed slots until locked in place as shown in [Figure 5](#).
2. The pole mounting bracket is attached to the BSAP in the same orientation, whether the BSAP will be mounted on the pole vertically or horizontally.

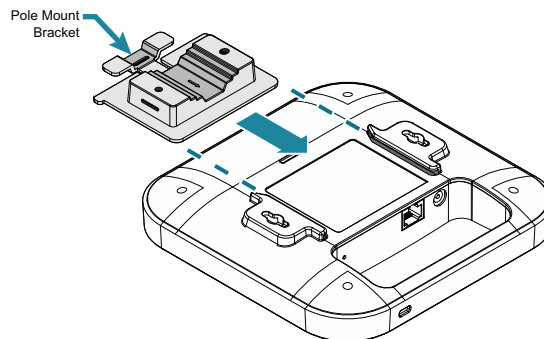

Figure 5. Attaching Pole Mount Bracket to BSAP

To mount the BSAP 6040 to a Vertical Pole:

1. Once the pole mounting bracket is attached to the BSAP, thread the hose strap through the two slots on the pole mount bracket as shown in [Figure 6](#) on page 4.

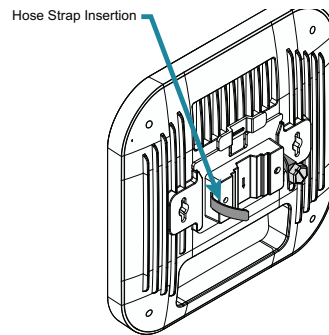

Figure 6. Attach the Pole Mounting Bracket for Vertical Mounting

2. Wrap the hose strap around the vertical mounting pole and insert the end into the strap lock. Tighten the strap lock to secure the unit to the pole as shown in [Figure 7](#).

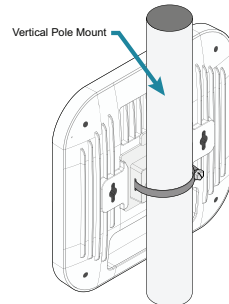

Figure 7. Vertical Pole Mounting of BSAP

Mounting the BSAP 6040 to a Horizontal Pole

1. Once the pole mounting bracket is attached to the BSAP, thread the hose strap through the two slots on the pole mount bracket as shown in [Figure 8](#).
2. Rotate the BSAP 90 degrees so that pole mount bracket and hose straps are aligned vertically (as shown in [Figure 8](#)).

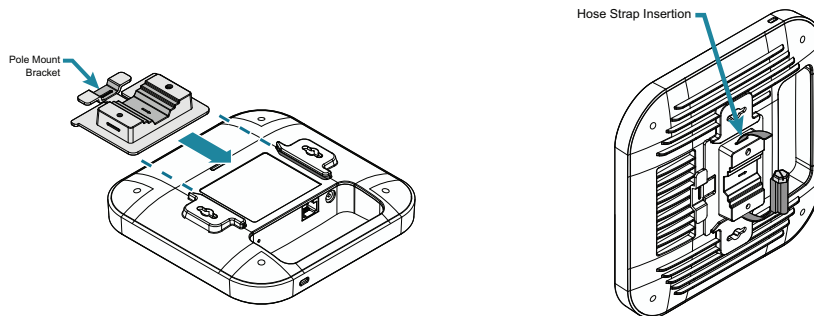

Figure 8. Attach the Pole Mounting Bracket and Straps for Horizontal Mounting

3. Wrap the hose strap around the horizontal mounting pole and insert the end into the strap lock. Tighten the lock of the hose strap to secure the unit to the pole ([Figure 9](#)).

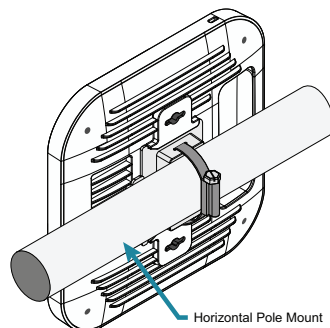

Figure 9. Horizontal Pole Mount

Mounting the BSAP 6040 to a Junction Box

The BSAP 6040 can also be mounted to a junction box using the ADTRAN junction box mounting kit. This kit is sold separately and not included with the base product shipment (PN 1700978F1 - Junction Box Mount Kit for BSAP 6040/6020). Refer to the instructions below for installation. The junction box mounting kit includes the bracket, two #6 (32 x 3/4 inch) screws, and two #8 (32 x 3/4 inch) screws.

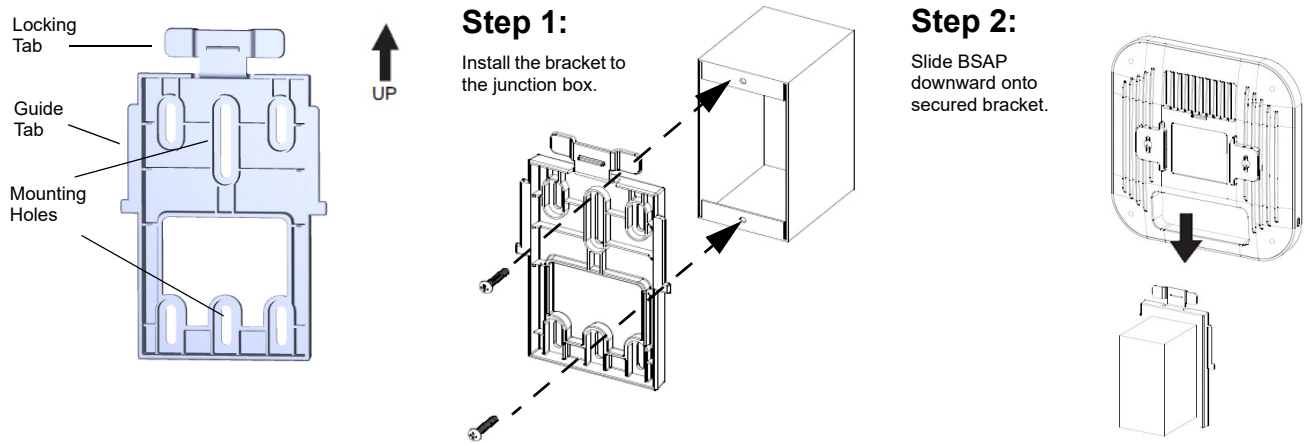

Figure 10. Mounting the BSAP to a Junction Box Bracket

Mounting the BSAP to a Junction Box

BSAPs should be positioned for maximum throughput and range between other APs and wireless client devices. Follow these instructions to mount the BSAP to an interior junction box using the enclosed mounting kit:

1. Align the mounting holes in the bracket with the mounting holes in the junction box. Make sure to keep the mounting bracket oriented so that the locking tab is at the top.
2. Drive the provided appropriate-sized screws through the mounting holes in the bracket into the mounting holes of the junction box, and ensure that the bracket is snug against the junction box.
3. Once the bracket is securely attached to the junction box, align the back of the BSAP with the mounting bracket so that the BSAP can slide downwards onto the mounting bracket with the bracket's guide tabs engaged with the BSAP's guide rails.
4. Slide the BSAP down the mounting bracket until the bottom of the BSAP aligns with the bottom edge of the mounting bracket. You should feel the mounting bosses align with the keyed slots at the back of the BSAP.
5. When the mounting bosses are fully inserted and the BSAP is resting flush against the mounting bracket, slide the BSAP downward until it snaps into place, engaging the locking tab.

Remove the BSAP from the Bracket

To remove the BSAP from the mounting bracket, follow these steps:

1. Press the locking tab away from the BSAP to disengage the locking mechanism.
2. Slowly slide the BSAP upwards to remove it from the bracket.

Supplying Power to the BSAP 6040

The BSAP 6040 does not have a power switch. It is powered when connected to a network device that supplies PoE+ based on the IEEE 802.3at standard, or optionally by the following:

- External 802.3at PoE+ injector connected to a properly grounded AC power outlet (54 VDC, 0.6A minimum PoE+ injector).
- External AC/DC power adapter connected to an AC power source (12 VDC, 2.5A minimum AC/DC power adapter).
- The PoE+ injector and AC/DC power adapter are optional accessories and sold separately by ADTRAN.



NOTE

To use PoE+ network devices for powering the BSAP 6040, connect the PoE+-based network device to the **2.5Gb PoE+** port (labeled 1 on the bottom of the unit, as shown in [Figure 1](#) on page 1).

To use the external DC power adapter, connect the adapter to the **12V DC** port on the back of the unit. The DC power adapter automatically adjusts to any voltage between 100 and 240 VAC at 50 or 60 Hz. No voltage range settings are required.



CAUTION!

This product is intended for indoor use only. Ethernet, PoE cables, and attached equipment are intended for use within the same building with equipotential bonding, and not intended to be placed in separate buildings or structures. Failure to deploy as described could result in permanent damage from lightning or other electrical events and voids the warranty.

Connecting to the BSAP 6040

Once the BSAP 6040 is installed and powered, you can connect to the AP using one of the methods described in the following section.

Connecting to the BSAP 6040 Using a Network Device

If powering the BSAP 6040 using a network device such as a switch:

1. Connect one of the BSAP 6040 Ethernet ports to the appropriate switchport.
2. Obtain the IP address of the AP from the Dynamic Host Control Protocol (DHCP) server based on the MAC address of the BSAP 6040. DHCP is enabled by default.
3. Use a Secure Shell (SSH) client to connect to the default IP address of the BSAP.

Connecting to the BSAP 6040 Using a PoE+ Injector

If powering the BSAP 6040 using a PoE+ injector:

1. Connect one of the Ethernet ports of the BSAP to the **OUT** port of the PoE+ injector.
2. Connect the Ethernet port of the computer to the **IN** port on the PoE+ injector.
3. Use a Secure Shell (SSH) client to connect to the default IP address of the BSAP.

Connecting to the BSAP 6040 Using the DC Power Adapter

If the BSAP is powered using the optional DC power adapter:

1. Connect the Ethernet port of the BSAP to the Ethernet port of the computer.
2. Use a Secure Shell (SSH) client to connect to the default IP address of the BSAP.

Managing the BSAP 6040

You can connect to and manage the BSAP 6040 using one of ADTRAN's cloud management services or by using the BSAP's command line interface (CLI). Each service offering and management method is described in the following sections.

Managing the BSAP 6040 with Express Cloud

Express Cloud is now included with the purchase of new ADTRAN Bluesocket 6040 series APs. Express Cloud can be used with the BSAP 6040, however Elite Cloud or Elite On-Premises can be purchased for access to upgraded features.

For initial setup of Express Cloud:

1. Go to <https://adtran.com/cloud> and provide the requested information to create a new account. Express Cloud access information and credentials will be sent via email within one business day.
2. After receiving e-mail confirmation, connect the BSAP to a power supply.
3. Connect the BSAP to an Internet-accessed network. The BSAP will automatically discover Express Cloud and will display in the account.

For existing Express Cloud accounts adding additional BSAPs:

1. Go to <https://adtran.com/cloud>.
2. Using the same email address as the existing Express Cloud account in the email field and the domain name in the company field.
3. If using an email address that already has an account and a domain that already exists, you will be adding additional BSAPs to that existing account and domain.
4. Confirmation that BSAPs have been added will be sent via email within one business day.
5. After receiving e-mail confirmation, connect the BSAP to a power supply.
6. Connect the BSAP to an internet-accessed network. The BSAP will automatically discover Express Cloud and will display in the account.

Express Cloud support is available in the ADTRAN interactive support community online at <https://supportcommunity.adtran.com>.



NOTE

For further details regarding Express Cloud, Elite Cloud, and Elite On-Premises, refer to the FAQ in the support community. For further information on creating an Express Cloud account, refer to the [Creating an Express Cloud Account](#) article in the support community.

Managing the BSAP 6040 with Elite Cloud

Purchasing an Elite Cloud subscription automatically creates a user cloud account. All further communication regarding the subscription will be provided via email.

For initial setup of Elite Cloud:

1. Elite Cloud access information and credentials will be sent via email within one business day.
2. After receiving e-mail confirmation, connect the BSAP to a power supply.
3. Connect the BSAP to an internet-accessed network. The BSAP will automatically discover Elite Cloud and will display in the account.

For existing Elite Cloud accounts purchasing additional BSAPs and Elite Cloud Subscriptions:

1. Confirmation that the BSAPs have been added will be sent via email within one business day.
2. After receiving e-mail confirmation, connect the BSAP to a power supply.
3. Connect the BSAP to an internet-accessed network. The BSAP will automatically discover Elite Cloud and will display in the account.

Managing the BSAP 6040 with Elite On-Premises and AP Discovery

The BSAP 6040 can be configured for use with Elite On-Premises, the Bluesocket virtual wireless local area network (vWLAN) management system. Using AP discovery to configure the BSAP with a previously-installed vWLAN instance can be achieved by allowing the BSAP to discover the vWLAN instance and receive its configuration information. This AP discovery process uses an algorithm that attempts discovery methods in this order: static configuration, Dynamic Host Control Protocol (DHCP) vendor option (43), Domain Naming System (DNS) discovery, cached vWLAN information, and Express/Elite Cloud Zero Touch discovery. If no response to the discovery request is received, the algorithm moves to the next method in the list (except when using static configuration, which never queries the other discovery methods).

Two additional network components can be configured to facilitate AP discovery:

1. An external DHCP server can be configured to assign IP addresses to the BSAPs associated with the vWLAN instance. When configuring the DHCP server, make sure to configure the Bluesocket DHCP Vendor option (**43**) on the server.
2. An external DNS server can be configured to resolve the name **apdiscovery** to the IP address of the vWLAN in the network environment. When using DNS, only the A records are needed and required to be configured.



NOTE

When running static configuration, the BSAPs will not automatically query the other AP discovery methods.

For more information on the vWLAN and AP discovery, refer to the [vWLAN AP Discovery Configuration Guide](https://supportcommunity.adtran.com) available online at <https://supportcommunity.adtran.com>.

Configuring the BSAP 6040 IP Address or Static Discovery Using the CLI

By default, DHCP is enabled on the BSAP 6040. However, if static configuration is required for the IP address or AP discovery for the BSAP, users can access the BSAP's CLI using either a VT100 terminal emulation program or an SSH client.

To access the BSAP 6040 CLI using a VT100 terminal emulation program, follow these steps:

1. Connect a DB-9 to RJ-45 serial cable (rollover cable) to the BSAP's **CONSOLE** port, and connect the other end of the serial cable to the PC.
2. Open a VT100 terminal emulation program with the following settings: **115,200** data rate, **eight** data bits, no parity bits, and **1** stop bit (no flow control).
3. Select **<Enter>** to access the CLI. At the prompt, enter the user name **adm1n** and the password **blue1socket**.

To access the BSAP CLI using an SSH client, complete these steps:

1. Ensure that the BSAP is connected to a controlling computer (using the provided RJ-45 Ethernet cable).
2. Specify that the computer's TCP/IP setting is **On** or **Enabled** by navigating to **Control Panel** and selecting **Network Connections**.
3. Double-click the connection of your network interface card and select **Internet Protocol (TCP/IP)**.
4. Select **Properties** then specify that the TCP/IP setting is enabled.
5. Set your PC to a static IP address of **192.168.190.2** with a subnet mask of **255.255.255.0**.
6. Access the BSAP's command line interface (CLI) using an SSH client.
7. Open an SSH connection using the unit's DHCP-assigned IP address and port **2335** connected to the **LAN1** port on the BSAP.
8. At the prompt, enter the user name **adm1n** and the password **blue1socket**.



















NOTE





























If DHCP is not enabled, you can connect to the BSAP using the default IP address of **192.168.190.1**. To use this method, make sure that the BSAP is in the same subnet as the PC configured in Step 5.

Configuring the Application

More detailed information about configuring the BSAP 6040, refer to the [vWLAN Administrator's Guide](https://supportcommunity.adtran.com), available online at <https://supportcommunity.adtran.com>. Additional safety and regulatory guidelines are also available in the [Bluesocket Compliance Notice](https://supportcommunity.adtran.com) available online at <https://supportcommunity.adtran.com>.

BSAP 6040 LED Descriptions

LED Array						BSAP State
 (Solid)	 (Solid)	 (Solid)	2.4 GHz (Solid)	5 GHz (Solid)	 (Solid)	Boot Loader Initialization
 (Solid)	 (Off)	 (Off)	2.4 GHz (Off)	5 GHz (Off)	 (Off)	Operating System Initialization
 (Flashing)	 (Flashing)	 (Off)	2.4 GHz (Off)	5 GHz (Off)	 (Off)	LAN Initialization
 (Solid)	 (Flashing)	 (Off)	2.4 GHz (Off)	5 GHz (Off)	 (Off)	Discovering vWLAN

LED Array						BSAP State
 (Solid)	 (Flashing)	 (Off)	2.4 GHz (N/A)	5 GHz (N/A)	 (Off)	Firmware Upgrade (Download)
 (Solid)	 (Flashing)	 (Off)	2.4 GHz (N/A)	5 GHz (N/A)	 (Off)	Firmware Upgrade (writing or verifying)
 (Solid)	 (Flashing)	 (Off)	2.4 GHz (N/A)	5 GHz (N/A)	 (Off)	Firmware Upgrade Complete
 (Solid)	 (Flashing)	 (Off)	2.4 GHz (Flashing 2.4G LED only)	5 GHz (Flashing 5G LED only)	 (Off)	Operational with No Activity on Radios (scanning radio dis- abled)
 (Solid)	 (Flashing)	 (Off)	2.4 GHz (Flashing 2.4G LED only)	5 GHz (Flashing 5G LED only)	 (Off)	Operational with Activity on Radios (scanning radio dis- abled)
 (Solid)	 (Flashing)	 (Off)	2.4 GHz (Flashing 2.4G LED only)	5 GHz (Flashing 5G LED only)	 (Flashing 5G LED only)	Operational with No Activity on Radios (scanning radio active)
 (Solid)	 (Flashing)	 (Off)	2.4 GHz (Flashing 2.4G LED only)	5 GHz (Flashing 5G LED only)	 (Flashing 5G LED only)	Operational with Activity on Radios (scanning radio active)

Product Specifications

Electrical

- Input: 802.3at Compliant PoE+ source (PoE+ Input: 54 VDC, 0.6A)
- External Power Supply: 12 VDC, 2.5A
- Power Consumption: 24W (USB excluded)

Environment

- Operating Temperature: 32°F to 104°F (0°C to 40°C)
- Storage Temperature: -40°F to 158°F (-40°C to 70°C)
- Relative Humidity: 10 to 95 percent, non-condensing



CAUTION!

Electrostatic Discharge (ESD) can damage electronic devices. When handling devices, wear an antistatic discharge wrist strap to prevent damage to electronic components. Place in antistatic packing material when transporting or storing. When installing or maintaining, always place devices on an approved antistatic mat that is electrically grounded.



CAUTION!

This product is intended for business deployment. Care should be taken to protect cables from damage or vandalism.



CAUTION!

Do not locate the product in direct sunlight or next to any thermal obstructions or source of moisture.

**NOTE**

Changes or modifications not expressly approved by ADTRAN will void the warranty.

Compliance

- Changes or modifications not expressly approved by ADTRAN could void the user's authority to operate this equipment.
- IEEE 802.3at PoE+
- FCC
 - ◆ Subpart 15 B
 - ◆ Subpart C 15.247
 - ◆ Subpart E 15.407
- CAN ICES-003 (B) / NMB-003 (B)
- UL Listed

FCC Statements

- This device complies with Part 15 of the FCC rules. Operation is subject to the following two conditions:
 - 1. This device may not cause harmful interference.
 - 2. This device must accept any interference received, including interference that may cause undesired operation.
- This equipment complies with FCC radiation exposure limits set forth for an uncontrolled environment. This equipment should be installed and operated with minimum distance 25 cm between the radiator and your body.
- This transmitter must not be co-located or operating in conjunction with any other antenna or transmitter.
- Changes or modifications not expressly approved by ADTRAN could void the user's authority to operate the equipment.

**NOTE**

This equipment has been tested and found to comply with the limits for a Class B digital device, pursuant to part 15 of the FCC Rules. These limits are designed to provide reasonable protection against harmful interference in a residential installation. This equipment generates, uses and can radiate radio frequency energy and, if not installed and used in accordance with the instructions, may cause harmful interference to radio communications. However, there is no guarantee that interference will not occur in a particular installation. If this equipment does cause harmful interference to radio or television reception, which can be determined by turning the equipment off and on, the user is encouraged to try and correct the interference by one or more of the following measures:

- Reorient or relocate the receiving antenna.
- Increase the separation between the equipment and the receiver.
- Connect the equipment into an outlet on a circuit different from that to which the receiver is connected.
- Consult the dealer or an experienced radio/TV technician for help.

ISED Statement

This device contains license-exempt transmitter(s) that comply with Innovation, Science and Economic Development Canada's license-exempt RSS(s). Operation is subject to the following two conditions:

- This device may not cause interference;
- This device must accept any interference, including interference that may cause undesired operation of the device.

L'émetteur exempt de licence contenu dans le présent appareil est conforme aux CNR d'Innovation, Sciences et Développement économique Canada applicables aux appareils radio exempts de licence. L'exploitation est autorisée aux deux conditions suivantes :

- L'appareil ne doit pas produire de brouillage;
- L'appareil doit accepter tout brouillage radioélectrique subi, même si le brouillage est susceptible d'en compromettre le fonctionnement.

Documentation for ADTRAN Network Solutions products is available for viewing and download directly from the ADTRAN Support Community website.

Go to: <https://supportcommunity.adtran.com>

ADTRAN offers training courses on our products, including customized training and courses taught at our facilities or at customer sites.

For inquiries, go to: <http://adtran.com/training>

Access additional safety information and updated product documentation using the QR code, or find additional resources from the ADTRAN Support Community website.



<https://supportcommunity.adtran.com>

Warranty: ADTRAN will replace or repair this product within the warranty period if it does not meet its published specifications or fails while in service. Warranty information can be found online at www.adtran.com/warranty-terms.

Trademarks: Brand names and product names included in this document are trademarks, registered trademarks, or trade names of their respective holders.

Copyright © 2023 ADTRAN, Inc. All Rights Reserved.



ADTRAN CUSTOMER CARE:

From within the U.S. 1.888.423.8726

From outside the U.S. +1 256.963.8716

PRICING AND AVAILABILITY 1.800.827.0807

