



Configuration Guide

Configuring Media Anchoring in AOS

This configuration guide outlines the use and configuration of the media anchoring feature in ADTRAN Operating System (AOS) products. The guide includes an overview of the media anchoring process, the steps necessary to configure media anchoring using the command line interface (CLI), and media anchoring troubleshooting information.

This guide consists of the following sections:

- *Media Anchoring Overview on page 2*
- *Hardware and Software Requirements and Limitations on page 4*
- *Configuring Media Anchoring on page 5*
- *Media Anchoring Configuration Examples on page 7*
- *Media Anchoring Configuration Command Summary on page 7*
- *Troubleshooting on page 8*

Media Anchoring Overview

Media anchoring is a feature of AOS products used to force Realtime Transfer Protocol (RTP) packets to ingress and egress the local network through the AOS device, thus providing extra security for the local network and anchoring the RTP stream to interfaces on the AOS device. In this application, all RTP packets generated in the local network are directed, through the use of Session Description Protocol (SDP), to the AOS device. When outgoing RTP packets are generated from the local network, heading for the public network, their source IP address and port number are modified to be sourced from the AOS device. In addition, the original destination IP address and port of the RTP packet (the IP address and port of the AOS device), are modified to be destined for the public network. When incoming RTP packets are received from the public network, heading for the local network, their source IP address and port are modified to be sourced from the AOS device, and their destination IP address and port are modified to be destined to the IP PBX or phone on the local network. This modification of RTP packet source and destination IP addresses and ports occurs by modifying the SDP attributes and the IP header of the RTP packets. *Figure 1* describes the RTP packet flow through a network with media anchoring enabled on the AOS device.

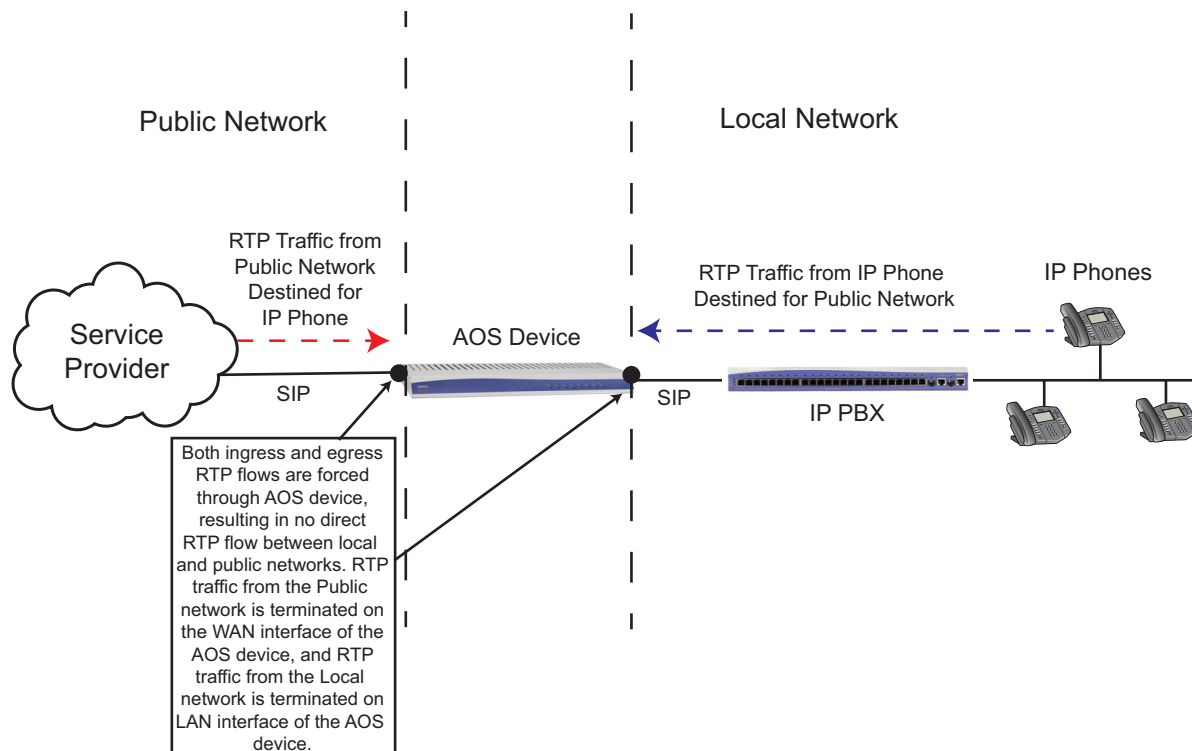

Figure 1. RTP Packet Traffic on a Network with Media Anchoring

How Media Anchoring Works

When calls that require anchoring are generated, media anchoring entries are created (or updated) and stored. As RTP streams flow, the source and destination of the packets is encoded with the translated IP addresses and ports.

When media anchoring is enabled, the SDP connection information (IP address and media description port(s)) are changed so that the AOS device becomes the destination for the RTP packets. The media anchoring feature determines the appropriate IP address to place in the SDP based on the interface to which the RTP is destined. Ports are chosen from the media anchoring port range, for both RTP and Realtime Transport Control Protocol (RTCP). These changes are made in both the SDP offer and answer. In addition, when calls are anchored, an association is formed between the media anchoring entries stored by the feature. This association allows the RTP flow to proceed. The media anchoring entries become associated with the RTP flow once a packet from each side of the AOS device has been received (when performing SDP override using the remote phone functionality) or once the first RTP packet from either side is received. This allows the destination IP and port of each media anchoring entry to be updated with the source IP and port from the RTP of the associated entry when SDP override is in use by the remote phone functionality.



For more information about the remote phone functionality, and its configuration, refer to the configuration guide [Remote Phone Configuration for AOS SIP Gateway](http://supportforums.adtran.com), available online at <http://supportforums.adtran.com>.

In addition to changing SDP connection information for the RTP packet, media anchoring also manipulates the IP header of the RTP packet. When a packet arrives, if its User Datagram Protocol (UDP) port is within the range of ports used for media anchoring, then the original IP address and UDP port number are substituted with the destination address and port that are associated with the source address and port of the incoming packet.

The Media Anchoring Process

When media anchoring is enabled, the AOS device acts as a gate between the public network and the local network for RTP streams. For example, suppose a local Voice over IP (VoIP) phone makes a call from the local side of the network to the public network, and the local network is configured to have all Session Initiation Protocol (SIP) messages routed through the AOS device. The AOS device receives the SIP message with an SDP offer from the IP phone when it attempts to make the call, and based on the SDP offer, determines the egress interface for relaying the SDP message to the public network. The media gateway IP address of that interface is substituted for the connection information IP address contained in the original SDP offer, and the port number is replaced with a port number in the media anchoring range of ports. The modified SDP offer is then relayed to the device on the public network called by the phone using the appropriate outbound SIP trunk, which causes any return RTP traffic from the public network to be routed through the AOS device, rather than directly to the calling IP phone.

When the AOS device receives the SDP answer from the destination endpoint, the SDP connection information IP address and media description UDP port numbers are replaced with the media gateway IP address of the interface to which the SDP answer was originally destined (the interface on which the VoIP phone can be reached) and a second port number within the media anchoring UDP port range. This action causes RTP streams from the VoIP phone and the PSTN to be routed to the AOS device instead of directly between the two endpoints.

Once the substitutions are made, and both endpoints use the AOS device to relay communications, an RTP session begins and packets inbound from the public network will have the far-end IP address as the source and the AOS device as the destination. The media anchoring feature replaces the source address with the egress (to the IP phone) interface's IP address and the destination address with that of the VoIP phone. The same operations occur with packets inbound from the IP phone to the AOS device. These packets have the

IP phone's source IP address and UDP port as their source and the AOS device as the destination. The source IP address is changed to that of the egress (to the public network) interface's media gateway, and the port is changed to the media anchoring port established when the SDP offer was originally manipulated. The destination IP address and UDP port are changed to that of the public endpoint. These operations are the same whether the call originates from the public network, an IP PBX, or a remote phone.

Figure 2 describes the SDP process, source and destination substitutions, and IP address and port associations formed when media anchoring is enabled.

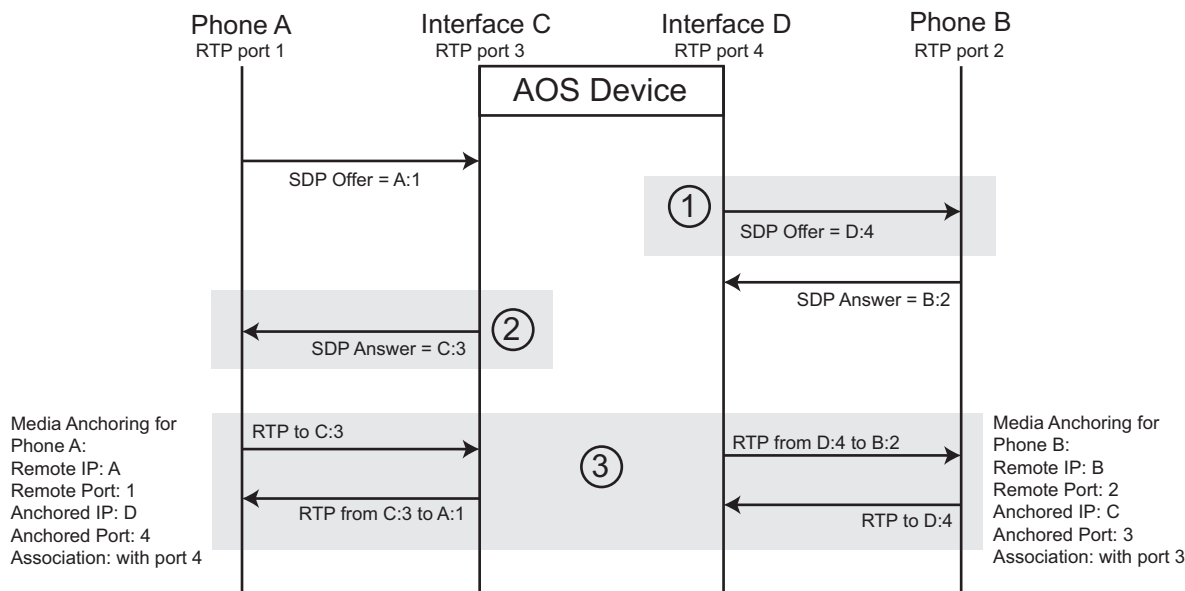

Figure 2. SDP Processes, Associations, and Media Anchoring Call Flows

Media Anchoring Time to Live (TTL)

Each media anchoring entry stored by the AOS device contains a TTL value that is decremented by a background timer. The TTL is initialized at the point the entry is activated by media anchoring. The TTL of the current entry (and its associated entry) is refreshed by RTP activity, ensuring that both flows remain active. The TTL for media anchoring entries is user configurable.

Hardware and Software Requirements and Limitations

The media anchoring feature is available on AOS products as outlined in the *AOS Feature Matrix*, available online at <http://supportforums.adtran.com>.

Media anchoring can be configured on a global basis to act upon all SIP calls, or no SIP calls. When enabled, media anchoring anchors RTP, RTCP, and UDP Transport Layer (UDPTL) (for T.38) packets and all media streams associated with a call. Anchoring does not interfere with back-to-back user agents (B2BUAs) for calls where one endpoint is a Time-division Multiplexing (TDM) endpoint, and it is interoperable with SIP proxy.

There is a maximum number of calls that can be anchored, depending on the AOS product. Refer to the *AOS Feature Matrix*, available online at <http://supportforums.adtran.com>, to find the maximum number of supported media anchoring calls for your particular platform.

The source address for outbound anchored RTP packets is not configurable, and it defaults to the media gateway IP address of the egress interface.

Media anchoring can be used to anchor media from a remote phone.

This feature functions with your choice of beginning port number for the general RTP port range. The AOS firewall cannot use ports reserved for media anchoring as source ports for any other use.

Configuring Media Anchoring

Media anchoring is configured using the CLI following these steps:

1. Access the CLI.
2. Enable media anchoring.
3. Specify the media anchoring port range (optional).
4. Specify the TTL of media anchoring entry associations (optional).
5. Specify the RTP symmetric filtering settings (optional).

Step 1: Accessing the CLI

To access the CLI on your AOS unit, follow these steps:

1. Boot up the unit.
2. Telnet to the unit (**telnet** <ip address>), for example:

telnet 10.10.10.1.



If during the unit's setup process you have changed the default IP address (10.10.10.1), use the configured IP address.

3. Enter your user name and password at the prompt.



*The AOS default user name is **admin** and the default password is **password**. If your product no longer has the default user name and password, contact your system administrator for the appropriate user name and password.*

4. Enable your unit by entering **enable** at the prompt as follows:
>enable
5. If configured, enter your Enable mode password at the prompt.
6. Enter the unit's Global Configuration mode as follows:

#configure terminal
(config)#

Step 2: Enabling Media Anchoring

Enable media anchoring using the **ip rtp media-anchoring** command from the Global Configuration mode. This command enables media anchoring on a global basis for all RTP calls. By default, media anchoring is disabled. Using the **no** form of this command disables the media anchoring feature.

To enable media anchoring, enter the command as follows from the Global Configuration mode:

```
(config)#ip rtp media-anchoring
(config)#
```

Step 3: Specifying the Media Anchoring Port Range (Optional)

RTP packets are sent through the AOS unit towards either the digital signal processor (DSP) within the AOS unit (on products that contain a DSP), or to the media anchoring feature. Media anchoring port ranges begin immediately after the end of the DSP port range. For RTP streams to be anchored, they must pass through a media anchoring port. This means you must configure the RTP port range correctly to accommodate both DSP and media anchoring RTP ports. You can specify the beginning RTP port by entering the **ip rtp udp <number>** command from the Global Configuration mode prompt. The *<number>* parameter is the beginning port. Valid beginning port range is **1026** to **60000**. By default, RTP streams use port **10000** as a beginning port. Using the **no** form of this command returns the beginning UDP port used by RTP to the default port.

To specify a beginning UDP port for RTP other than the default, enter the command as follows from the Global Configuration mode:

```
(config)#ip rtp udp 20000
(config)#
```

Step 4: Specifying the TTL of Media Anchoring Entry Associations

After you have enabled media anchoring, you can specify the TTL for media anchoring entry associations using the **ip rtp session timeout <value>** command. This command allows you to specify the TTL, in seconds, of an anchoring association after the associated RTP flow ends. This is beneficial in cases where an RTP call is not torn down by normal methods. The *<value>* is the timeout period, which has a valid range of **32** to **900** seconds. By default, the TTL of media anchoring associations is **45** seconds. Using the **no** form of this command returns the TTL to the default value.

To change the TTL for media anchoring entry associations, enter the command as follows from the Global Configuration mode:

```
(config)#ip rtp session timeout 90
(config)#
```

Step 5: Specifying RTP Symmetric Filtering Settings (Optional)

Media anchoring honors the configured settings for RTP symmetric filtering. This parameter filters nonsymmetric RTP packets, and is disabled by default. If this feature is enabled, media anchoring will drop RTP packets destined to a particular port that are sourced from an unexpected IP address or port. To enable the RTP symmetric filtering feature, use the **ip rtp symmetric-filter** command. Use the **no** form of this command to disable the feature.

To enable RTP symmetric filtering, enter the command as follows from the Global Configuration mode:

```
(config)#ip rtp symmetric-filter
(config)#
```

Media Anchoring Configuration Examples

The example scenarios contained within this section are designed to enhance understanding of media anchoring configurations on AOS products. The examples describe some of the common real-world media anchoring configurations. All configurations provided in this section use the command line interface (CLI).



The configuration parameters entered in these examples are sample configurations only. These applications should be configured in a manner consistent with the needs of your particular network. CLI prompts have been removed from the configuration examples to provide a method of copying and pasting configurations directly from this configuration guide into the CLI. These configurations should not be copied without first making the necessary adjustments to ensure they will function properly in your network.

In the following example, media anchoring is configured on an AOS device with an RTP port range beginning at port **20000**, a TTL value of **90** seconds, and with RTP symmetric filtering.

```
!
ip rtp udp 20000
ip rtp media-anchoring
ip rtp session timeout 90
ip rtp symmetric-filter
!
```

Media Anchoring Configuration Command Summary

The following table summarizes the commands used to configure media anchoring in AOS products.

Table 1. Media Anchoring Command Summary

Prompt	Command	Description
(config)#	[no] ip rtp udp <value>	Sets the beginning port for the RTP port range in the AOS device. The media anchoring port range begins immediately after the end of the DSP port range. Valid range is 1026 to 60000 . By default, the RTP port range begins at port 10000 .

Table 1. Media Anchoring Command Summary (Continued)

Prompt	Command	Description
(config)#	[no] ip rtp media-anchoring	Enables media anchoring on a global basis for all RTP to RTP calls. By default, media anchoring is disabled.
(config)#	[no] ip rtp session timeout <value>	Specifies the default TTL (in seconds) of an anchoring association after the associated RTP flow ends. Valid range is 32 to 900 seconds, with a default value of 45 seconds.
(config)#	[no] ip rtp symmetric-filter	Enables filtering of received nonsymmetric RTP packets. When enabled, media anchoring drops packets destined to a particular port that are sourced from an unexpected IP address or port. By default, symmetric filtering is disabled.

Troubleshooting

The following **show** and **debug** commands can be used to view all media anchoring associations, the number of relayed packets per association, and to enable debug messages for media anchoring. These commands are all entered from Enable mode.

Use the **show ip rtp media sessions** command to display all of the anchored RTP flow associations and the number of relayed packets per association currently active in an anchored RTP flow. In addition, the TTL and the session type (digital signal processing (DSP), media-anchored, or transcoded) for the association is displayed.

To display media information, enter the command as follows:

>enable

#show ip rtp media sessions

Call ID	Anchored Address	Remote Address	TTL	Packets	Ovrrd	Type	Session
7	10.10.10.1:40008	10.10.10.2:2230	45	108062	No	Audio	DSP
7	10.17.250.12:40010	10.17.250.14:10262	45	108063	No	Audio	DSP
7	10.10.10.1:40009	10.10.10.2:2231	44	432	No	Audio	DSP
7	10.17.250.12:40011	10.17.250.14:10263	44	432	No	Audio	DSP

Use the **debug ip rtp media-anchoring** command to enable debug messaging for media anchoring activity. Debug messages are generated for media anchoring functions, such as the beginning and ending of anchoring sessions, and the creation and destruction of associations. To enable media anchoring debug messages, enter the command as follows:

>enable

#debug ip rtp media-anchoring



Turning on a large amount of debug information can adversely affect the performance of your unit.