



DSU III AR
Data Service Unit

User Manual
Part Number
1202011L1

Trademark Information

Open View is a registered trademark of Hewlett-Packard Company.
SunNet Manager is a registered trademark of Sun Microsystems, Inc.
Netview is a registered trademark of IBM.
IQ View is a trademark of ADTRAN, Inc.
Hayes is a trademark of Hayes Microcomputer Products, Inc.

This product includes software developed by the University of California, Berkeley,
and its contributors.



901 Explorer Boulevard
P.O. Box 140000
Huntsville, AL 35814-4000
(256) 963-8000

© 2001 ADTRAN, Inc.
All Rights Reserved.
Printed in U.S.A.

The following conventions are used in this manual.



Notes provide additional useful information.



Cautions signify information that could prevent service interruption.



Warnings provide information that could prevent damage to the equipment or endangerment to human life.

FCC regulations require that the following information be provided in this manual:

1. This equipment complies with Part 68 of the FCC rules. On the bottom of the equipment housing is a label that shows the FCC registration number and Ringer Equivalence Number (REN) for this equipment, if applicable. If required, this information must be given to the telephone company.
2. The following information may be required when applying to the local telephone company for leased line facilities.

Service Type	Digital Facility Interface Code	Service Order Code	Network Jacks
2.4 kbps Digital Interface	04DU5-24	6.0F	RJ-48S
4.8 kbps Digital Interface	04DU5-48	6.0F	RJ-48S
9.6 kbps Digital Interface	04DU5-96	6.0F	RJ-48S
19.2 kbps Digital Interface	04DU5-19	6.0F	RJ-48S
38.4 kbps Digital Interface	04DU5-38	6.0F	RJ-48S
56 kbps Digital Interface	04DU5-56	6.0F	RJ-48S
64 kbps Digital Interface	04DU5-64	6.0F	RJ-48S

3. An FCC compliant telephone cord with a modular plug may be provided with this equipment. This equipment is designed to be connected to the telephone network or premises wiring using a compatible modular jack, which is FCC Part 68 compliant. See installation instructions for details.
4. If this equipment causes harm to the telephone network, the telephone company may temporarily discontinue service. If possible, advance notification is given; otherwise, notification is given as soon as possible. The telephone company will advise the customer of the right to file a complaint with the FCC.
5. The telephone company may make changes in its facilities, equipment, operations, or procedures that could affect the proper operation of this equipment. If this happens, the telephone company will provide advance notification and the opportunity to make the necessary modifications to maintain uninterrupted service.
6. If experiencing difficulty with this equipment, please contact ADTRAN for repair and warranty information. If the equipment is causing harm to the network, the telephone company may request this equipment to be disconnected from the network until the problem is resolved or it is certain that the equipment is not malfunctioning.
7. This unit contains no user serviceable parts.
8. The FCC recommends that the AC outlet to which equipment requiring AC power is to be installed is provided with an AC surge arrester.

Federal Communications Commission Radio Frequency Interference Statement

This equipment has been tested and found to comply with the limits for a Class A digital device, pursuant to Part 15 of the FCC Rules. These limits are designed to provide reasonable protection against harmful interference when the equipment is operated in a commercial environment. This equipment generates, uses, and can radiate radio frequency energy and, if not installed and used in accordance with the instruction manual, may cause harmful interference to radio frequencies. Operation of this equipment in a residential area is likely to cause harmful interference in which case the user will be required to correct the interference at his own expense.

Shielded cables must be used with this unit to ensure compliance with Class A FCC limits.



Change or modifications to this unit not expressly approved by the party responsible for compliance could void the user's authority to operate the equipment.

Affidavit Requirements for Connection to Digital Services

- An affidavit is required to be given to the telephone company whenever digital terminal equipment without encoded analog content and billing protection is used to transmit digital signals containing encoded analog content which are intended for eventual conversion into voice band analog signal and transmitted on the network.
- The affidavit shall affirm that either no encoded analog content or billing information is being transmitted or that the output of the device meets Part 68 encoded analog content or billing protection specification.
- End use/customer will be responsible to file an affidavit with the local exchange carrier when connecting unprotected CPE to a 1.544 Mbps or subrate digital service.
- Until such time as subrate digital terminal equipment is registered for voice applications, the affidavit requirements for subrate services are waived.

CANADIAN EQUIPMENT LIMITATIONS

Notice: The Canadian Industry and Science Canada label identifies certified equipment. This certification means that the equipment meets certain telecommunications network protective, operational, and safety requirements. The Department does not guarantee the equipment will operate to the user's satisfaction.

Before installing this equipment, users should ensure that it is permissible to be connected to the facilities of the local telecommunications company. The equipment must also be installed using an acceptable methods of connection. In some cases, the company's inside wiring associated with a single line individual service may be extended by means of a certified connector assembly (telephone extension cord). The customer should be aware that compliance with the above limitations may not prevent degradation of service in some situations.

Repairs to certified equipment should be made by an authorized Canadian maintenance facility designated by the supplier. Any repairs or alterations made by the user to this equipment, or equipment malfunctions, may give the telecommunications company cause to request the user to disconnect the equipment.

Users should ensure for their own protection that the electrical ground connections of the power utility, telephone lines and internal metallic water pipe system, if present, are connected together. This precaution may be particularly important in rural areas.

WARNING

Users should not attempt to make such connections themselves, but should contract the appropriate electric inspection authority, or an electrician, as appropriate.

The Load Number (LN) assigned to each terminal device denotes the percentage of the total load to be connected to a telephone loop which is used by the device, to prevent overloading. The termination on a loop may consist of any combination of devices subject only to the requirement that the total of the Load Numbers of all devices does not exceed 100.

CANADIAN EMISSIONS REQUIREMENTS

This digital apparatus does not exceed the Class A limits for radio noise emissions from digital apparatus as set out in the interference-causing equipment standard entitled "Digital Apparatus," ICES-003 of the Department of Communications.

Cet appareil numérique respecte les limites de bruits radioélectriques applicables aux appareils numériques de Class A prescrites dans la norme sur le matériel brouilleur: "Appareils Numériques," NMB-003 édictée par le ministre des Communications.

IMPORTANT SAFETY INFORMATION

When using your telephone equipment, please follow these basic safety precautions to reduce the risk of fire, electrical shock, or personal injury:

1. Do not use this product near water, such as near a bath tub, wash bowl, kitchen sink, laundry tub, in a wet basement, or near a swimming pool.
2. Avoid using a telephone (other than a cordless-type) during an electrical storm. There is a remote risk of shock from lightning.
3. Do not use the telephone to report a gas leak in the vicinity of the leak.
4. Use only the power cord, power supply, and/or batteries indicated in the manual. Do not dispose of batteries in a fire. They may explode. Check with local codes for special disposal instructions.

SAVE THESE INSTRUCTIONS

**Affidavit for Connection of Customer Premises Equipment to 1.544 MBPS and/
or Subrate Digital Services**

For the work to be performed in the certified territory of _____ (telco name)

State of _____

County of _____

I, _____ (name), _____ (business address),
_____ (telephone number) being duly sworn, state:

I have the responsibility for the operation and maintenance of the terminal equipment to be connected to 1.544 Mbps and/or _____ subrate digital services. The terminal equipment to be connected complies with Part 68 of the FCC rules except for the encoded analog content and billing protection specification. With respect to encoded analog content and billing protection:

- () I attest that all operations associated with the establishment, maintenance and adjustment of the digital CPE with respect to encoded analog content and billing protection information continuously complies with Part 68 of the FCC rules and Regulations.
- () The digital CPE does not transmit digital signals containing encoded analog content or billing information which is intended to be decoded within the telecommunications network.
- () The encoded analog content and billing protection is factory set and is not under the control of the customer.

I attest that the operator(s) maintainer(s) of the digital CPE responsible for the establishment, maintenance and adjustment of the encoded analog content and billing information has (have) been trained to perform these functions by successfully having completed one of the following (check appropriate blocks):

- () A. A training course provided by the manufacturer/grantee of the equipment used to encode analog signals; or
- () B. A training course provided by the customer or authorized representative, using training materials and instructions provided by the manufacturer/grantee of the equipment used to encode analog signals; or

() C. An independent training course (e.g., trade school or technical institution) recognized by the manufacturer/grantee of the equipment used to encode analog signals; or

() D. In lieu of the preceding training requirements, the operator(s)/maintainer(S) is (are) under the control of a supervisor trained in accordance with _____ (circle one) above.

I agree to provide _____ (telco's name) with proper documentation to demonstrate compliance with the information in the preceding paragraph, if so requested.

_____ Signature

_____ Title

_____ Date

Subscribed and sworn to before me

This _____ day of _____, 20__

Notary Public

My commission expires: _____

LIMITED PRODUCT WARRANTY

ADTRAN warrants that for five (5) years from the date of shipment to Customer, all products manufactured by ADTRAN will be free from defects in materials and workmanship. ADTRAN also warrants that products will conform to the applicable specifications and drawings for such products, as contained in the Product Manual or in ADTRAN's internal specifications and drawings for such products (which may or may not be reflected in the Product Manual). This warranty only applies if Customer gives ADTRAN written notice of defects during the warranty period. Upon such notice, ADTRAN will, at its option, either repair or replace the defective item. If ADTRAN is unable, in a reasonable time, to repair or replace any equipment to a condition as warranted, Customer is entitled to a full refund of the purchase price upon return of the equipment to ADTRAN. This warranty applies only to the original purchaser and is not transferable without ADTRAN's express written permission. This warranty becomes null and void if Customer modifies or alters the equipment in any way, other than as specifically authorized by ADTRAN.

EXCEPT FOR THE LIMITED WARRANTY DESCRIBED ABOVE, THE FOREGOING CONSTITUTES THE SOLE AND EXCLUSIVE REMEDY OF THE CUSTOMER AND THE EXCLUSIVE LIABILITY OF ADTRAN AND IS IN LIEU OF ANY AND ALL OTHER WARRANTIES (EXPRESSED OR IMPLIED). ADTRAN SPECIFICALLY DISCLAIMS ALL OTHER WARRANTIES, INCLUDING (WITHOUT LIMITATION), ALL WARRANTIES OF MERCHANTABILITY AND FITNESS FOR A PARTICULAR PURPOSE. SOME STATES DO NOT ALLOW THE EXCLUSION OF IMPLIED WARRANTIES, SO THIS EXCLUSION MAY NOT APPLY TO CUSTOMER.

In no event will ADTRAN or its suppliers be liable to Customer for any incidental, special, punitive, exemplary or consequential damages experienced by either Customer or a third party (including, but not limited to, loss of data or information, loss of profits, or loss of use). ADTRAN is not liable for damages for any cause whatsoever (whether based in contract, tort, or otherwise) in excess of the amount paid for the item. Some states do not allow the limitation or exclusion of liability for incidental or consequential damages, so the above limitation or exclusion may not apply to Customer.

Customer Service, Product Support Information, and Training

ADTRAN will replace or repair this product within five years from the date of shipment if the product does not meet its published specification, or if it fails while in service.

A return material authorization (RMA) is required prior to returning equipment to ADTRAN. For service, RMA requests, training, or more information, see the toll-free contact numbers given below.

Presales Inquiries and Applications Support

Please contact your local distributor, ADTRAN Applications Engineering, or ADTRAN Sales:

Applications Engineering (800) 615-1176

Sales (800) 827-0807

Post-Sale Support

Please contact your local distributor first. If your local distributor cannot help, please contact ADTRAN Technical Support and have the unit serial number available.

Technical Support (888) 4ADTRAN

The Custom Extended Services (ACES) program offers multiple types and levels of service plans which allow you to choose the kind of assistance you need. For questions, call the ACES Help Desk.

ACES Help Desk (888) 874-2237

Repair and Return

If ADTRAN Technical Support determines that a repair is needed, Technical Support will coordinate with the Custom and Product Service (CAPS) department to issue an RMA number. For information regarding equipment currently in house or possible fees associated with repair, contact CAPS directly at the following number:

CAPS Department (256) 963-8722

Identify the RMA number clearly on the package (below address), and return to the following address:

ADTRAN Customer and Product Service
901 Explorer Blvd.
Huntsville, Alabama 35806

RMA # _____

Training

The Enterprise Network (EN) Technical Training Department offers training on our most popular products. These courses include overviews on product features and functions while covering applications of ADTRAN's product lines. ADTRAN provides a variety of training options, including customized training and courses taught at our facilities or at your site. For more information about training, please contact your Territory Manager or the Enterprise Training Coordinator.

Training - phone (800) 615-1176, ext. 7500
Training - fax (256) 963 7941
Training - email training@adtran.com

Table of Contents

List of Figures	xix
------------------------------	------------

List of Tables	xxi
-----------------------------	------------

Chapter 1. Introduction

Product Overview	1-1
DDS Overview.....	1-2
4-Wire Switched 56 Overview.....	1-2

Chapter 2. Installation

Unpack, Inspect, Power Up	2-1
ADTRAN Shipments Include.....	2-1
Customer Provides	2-1
Power Up.....	2-2
Rear Panel	2-3
Network Interface Connection.....	2-4
DTE Data Connection/Primary DTE.....	2-4
Secondary Channel Connection.....	2-4

Chapter 3. Operation

Front Panel Menu Structure	3-1
Main Menu.....	3-1
Status	3-2
Test	3-2
Configuration (Config)	3-2
Dial	3-2
Basic Menu Travel.....	3-3
Enter	3-3
Up Arrow	3-3
Down Arrow	3-3

Cancel	3-3
Front Panel	3-5
LCD Window	3-5
Enter	3-5
Numeric Keypad	3-5
Up and Down Arrows	3-5
Cancel	3-5
Shift	3-6
Quick	3-6
LED Descriptions	3-6

Chapter 4. Configuration Overview

Local And Remote Configuration	4-1
Configuration Methods.....	4-2
VT-100 Connection.....	4-5
AT Commands.....	4-6
V.25 Bis Commands.....	4-7
SDLC Option	4-7
Character Format	4-7
Command Structure	4-7
Bi-Sync Option	4-7
Character Format	4-7
Command Structure	4-7
Asynchronous Option	4-8
Character Format	4-8
Command Structure	4-8
Command Descriptions	4-8
Syntax and Possible Responses	4-9
CIC (Connect Incoming Call)	4-9
CNL (Configuration Local)	4-10
CNR (Configuration Remote)	4-10
Switched 56 Operation	4-10
CRN (Call Request with Number)	4-10
CRS (Call Request Using Stored Number)	4-11
DIC(Disregard Incoming Call)	4-11
PRN (Program Number)	4-11
RLN (Request List of Numbers)	4-12

Chapter 5. Network Configuration

Network Options	5-1
Loop Rate.....	5-1

Network Address.....	5-3
Remote Configuration.....	5-4
Network Type.....	5-5
Clock Source	5-6
Chapter 6. Configuring DTE Options	
DTE Options	6-1
DTE Rate.....	6-2
Connector Type.....	6-5
Data Format	6-6
DTE Command Option	6-7
Transmit Clock	6-8
CS Options	6-10
Anti-Stream.....	6-12
Carrier Detect (CD) Options.....	6-13
TR Options	6-14
SR Options	6-15
Auxiliary Port	6-16
Chapter 7. Configuring Test Options	
Test Options	7-1
Test Time-out.....	7-1
Remote Digital Loopback	7-2
EIA Local Loopback.....	7-3
EIA Remote Loopback.....	7-4
Chapter 8. Configuring Dial Options	
Dial Options	8-1
Phone Number	8-1
Auto Answer.....	8-2
Chapter 9. Manual Command	
Manual Command	9-1
Using the Front Panel to Enter a Manual Command	9-2
Chapter 10. Dial Selection	
dial Options	10-1
Dial Stored Number.....	10-2
Enter Dial Number.....	10-2
Redial Last Number.....	10-2

Chapter 11. Testing and Troubleshooting

TEST OVERVIEW 11-1

- Initiating a Test 11-2
- Test Status Display 11-3
- Exiting a Test 11-3

Troubleshooting 11-5

- Messages from the DSU/CSU 11-5
- Troubleshooting New Installs 11-6
 - Test Sequence for Troubleshooting New Installs or Existing Circuits 11-8

Local Unit diagnostics 11-10

- DTE and Loop (LL) 11-12
 - Test Description 11-12
 - Test Purpose 11-12
 - Initiating 11-13
 - Interpreting Test Results 11-13
- Loop Only (RT) 11-14
 - Test Purpose 11-14
 - Initiating 11-15
 - Interpreting Test Results 11-15
- DTE Only 11-16
 - Test Purpose 11-16
 - Initiating 11-17
 - Interpreting Test Results 11-17
- DTE With Test Pattern 11-18
 - Test Purpose 11-18
 - Initiating 11-19
 - Interpreting Test Results 11-19
- Test Pattern 11-20
 - Test Purpose 11-20
 - Initiating 11-21
 - Interpreting Test Results 11-21
- Self Test 11-22
 - Test Purpose 11-22
 - Initiating 11-22
 - Interpreting Test Results 11-22

Remote Unit Diagnostics 11-23

- Test Purpose 11-24
- Initiating 11-24
- Test Results 11-24
- Interpreting Test Results 11-25

Chapter 12. Viewing Status Information

STATUS display	12-1
DSU Operational Status	12-2
DDS Network Status.....	12-3
Network Rate.....	12-4
DTE Rate/Mode.....	12-4
DTE Control Leads and Status.....	12-4
Appendix A. Pinouts	A-1
Appendix B. AT Commands	B-1
Appendix C. Default Configuration Profiles	C-1
Appendix D. EIA-232 Connector.....	D-1
Appendix E. DSU to DSU Tail Circuit.....	E-1
Appendix F. Specifications Summary.....	F-1
Appendix G. Acronyms/Abbreviations	G-1
Appendix H. Glossary	H-1
Index	Index-1

List of Figures

Figure 1-1. Sample Point-to-Point Application for DSU III AR.....	1-2
Figure 2-1. DSU III AR Rear View	2-3
Figure 3-1. Main Menu LCD Display	3-1
Figure 3-2. Example of Basic Menu Travel.....	3-4
Figure 3-3. DSU III AR Front View	3-5
Figure 4-1. Complete Configuration Menu	4-3
Figure 4-2. Configuration Menu with DTE Options	4-4
Figure 5-1. Setting Loop Rate Options	5-2
Figure 5-2. Setting the Network Address.....	5-3
Figure 5-3. Enabling/Disabling Remote Configuration	5-4
Figure 5-4. Setting Network Type Options.....	5-5
Figure 5-5. Setting the Clock Source	5-6
Figure 6-1. DTE Rates for 56 or 64 kbps Loop Rate with No Secondary Channel....	6-2
Figure 6-2. DTE Rates for 56 kbps Secondary Channel and 64 kbps Loop Rates	6-3
Figure 6-3. Selecting the Connector Type.....	6-5
Figure 6-4. Selecting Asynchronous or Synchronous Data Format	6-6
Figure 6-5. Selecting DTE Command Option.....	6-7
Figure 6-6. Transmit Clock Options.....	6-8
Figure 6-7. Selecting CS Options.....	6-10
Figure 6-8. Anti-Stream Options	6-12
Figure 6-9. Selecting CD Options.....	6-13
Figure 6-10. Selecting TR Options.....	6-14
Figure 6-11. Setting SR Options.....	6-15
Figure 6-12. Setting the Secondary Rate.....	6-16
Figure 7-1. Setting Test Time-out Option	7-1
Figure 7-2. Remote Digital Loopback.....	7-2

Figure 7-3. EIA Local Loopback Options	7-3
Figure 7-4. EIA Remote Loopback Options	7-4
Figure 8-1. Editing Stored Phone Numbers	8-1
Figure 8-2. Enabling/Disabling the Auto Answer Function.....	8-2
Figure 9-1. Menu Path for Manual Command	9-1
Figure 10-1. Dial Options Menu	10-1
Figure 10-2. Path to Storing Numbers Option.....	10-2
Figure 11-1. Normal Operation Before Initiating Loopback Test	11-1
Figure 11-2. Initiating a Test.....	11-2
Figure 11-3. Sample Test Status Displays.....	11-3
Figure 11-4. Complete Test Menu.....	11-4
Figure 11-5. DTE & Loop Test.....	11-12
Figure 11-6. Initiating a DTE & Loop Test.....	11-13
Figure 11-7. Loop Only Test	11-14
Figure 11-8. Initiating a Loop Only Test.....	11-15
Figure 11-9. DTE Only Test Diagram.....	11-16
Figure 11-10. Initiating a DTE Only Test	11-17
Figure 11-11. DTE with Test Pattern.....	11-18
Figure 11-12. Initiating a DTE Test with Test Pattern.....	11-19
Figure 11-13. Test Pattern Only.....	11-20
Figure 11-14. Initiating a Test Using a Test Pattern.....	11-21
Figure 11-15. Initiating a Self Test	11-22
Figure 11-16. V.54 RDL with Test Pattern.....	11-23
Figure 11-17. Initiating a Remote Test	11-24
Figure 12-1. Examples of Status Displays	12-1
Figure D-1. EIA-232 Connector.....	D-1
Figure E-1. DDS Tail Circuit	E-2
Figure E-2. Standard EIA-232-D Crossover Cable	E-3

List of Tables

Table 4-1.	Configuration Methods	4-2
Table 5-1.	Loop Rate Commands	5-2
Table 5-2.	Network Address Command	5-3
Table 5-3.	Remote Configuration Commands.....	5-4
Table 5-4.	Network Type Commands.....	5-5
Table 5-5.	Setting the Clock Source	5-6
Table 6-1.	DTE Rate AT Commands	6-2
Table 6-2.	Scrambler On/Off AT Commands	6-3
Table 6-3.	Data Format Commands	6-6
Table 6-4.	Transmit Clock AT Commands.....	6-8
Table 6-5.	CS Options AT Commands.....	6-11
Table 6-6.	Short and Long Delays at Different Operating Speeds.....	6-11
Table 6-7.	Anti-Stream AT Commands	6-12
Table 6-8.	CD Options AT Commands.....	6-13
Table 6-9.	TR Options AT Commands.....	6-14
Table 6-10.	SR Options AT Commands.....	6-15
Table 6-11.	Auxiliary Port AT Commands.....	6-17
Table 6-12.	DSU III AR Network Throughput	6-17
Table 7-1.	Test Timeout AT Commands.....	7-2
Table 7-2.	Remote Digital Loopback AT Commands.....	7-2
Table 7-3.	EIA Local Loopback AT Commands	7-3
Table 7-4.	EIA Remote Loopback AT Commands	7-4
Table 8-1.	AT Command for Storing Phone Numbers.....	8-2
Table 8-2.	AT Commands for Auto Answer	8-2
Table 9-1.	Manual Commands.....	9-3

Table 11-1. Messages from the DSU/CSU	11-5
Table 11-2. Troubleshooting New Installs.....	11-7
Table 11-3. AT Commands	11-9
Table 11-4. Test AT Commands.....	11-10
Table 11-5. DTE With Test Pattern Commands.....	11-11
Table 11-6. Remote Tests and AT Commands.....	11-23
Table A-1. RJ-48S Telco Connector Pinouts	A-1
Table A-2. Primary EIA-232 Connector Pinouts.....	A-2
Table A-3. Primary V.35 Connector Pinouts.....	A-3
Table A-4. Auxiliary EIA-232 Connector Pinouts	A-4
Table B-1. AT Commands	B-2
Table B-2. Loop Rate Commands.....	B-3
Table B-3. Network Address Command.....	B-3
Table B-4. Remote Configuration Commands	B-3
Table B-5. Network Type Commands.....	B-4
Table B-6. Clock Source Commands.....	B-4
Table B-7. DTE Rate AT Commands	B-4
Table B-8. Scrambler On/Off AT Commands.....	B-5
Table B-9. Data Format Commands.....	B-5
Table B-10. Transmit Clock AT Commands	B-5
Table B-11. CS Options AT Commands	B-6
Table B-12. Anti-Stream AT Commands	B-6
Table B-13. CD Options AT Commands	B-7
Table B-14. TR Options AT Commands	B-7
Table B-15. SR Options AT Commands	B-7
Table B-16. Secondary Rate AT Commands.....	B-8
Table B-17. Test Time-out AT Commands	B-8
Table B-18. Remote Digital Loopback AT Commands	B-8
Table B-19. EIA Local Loopback AT Commands	B-9
Table B-20. EIA Remote Loopback AT Commands	B-9
Table B-21. AT Command for Storing Phone Numbers.....	B-9
Table B-22. AT Commands for Auto Answer	B-9
Table B-23. Test AT Commands.....	B-10

Table B-24. DTE With Test Pattern Commands.....	B-11
Table B-25. Remote Tests and AT Commands.....	B-11
Table C-1. User Profiles	C-1
Table C-2. Default Configuration Profiles	C-2

Chapter 1 Introduction

PRODUCT OVERVIEW

The ADTRAN DSU III AR provides a reliable, high speed data connection for customer Data Terminal Equipment (DTE) through Digital Data Service (DDS) lines, DDS secondary channel services (DDSII), or 4-wire Switched 56 network (SW56) lines. The DSU III AR supports both synchronous and asynchronous data communication over the DDS or 4-wire Switched 56 networks.

This unit is an all rate DSU/CSU, supporting services from 2.4 to 64 kbps including 19.2 and 38.4 kbps services. The DSU III AR may be used in either point-to-point or multi-point circuits.

The DSU III AR provides both V.35 and EIA-232 electrical and physical DTE interfaces to accommodate a variety of applications. A second EIA-232 interface is provided for use on DDS lines with secondary channel services.

To ensure a reliable connection, the unit features an extended receiver capability which permits operation over long loops (3.4 miles or 5.5 km of 26 AWG at 56 kbps).

In addition to DDS, the unit supports Switched 56 (4-wire) service with dialing accomplished from the front panel. This model is compatible with AT&T Accunet and Sprint SW56 type services.

Figure 1-1 on page 1-2 shows a sample point-to-point application for the DSU III AR.

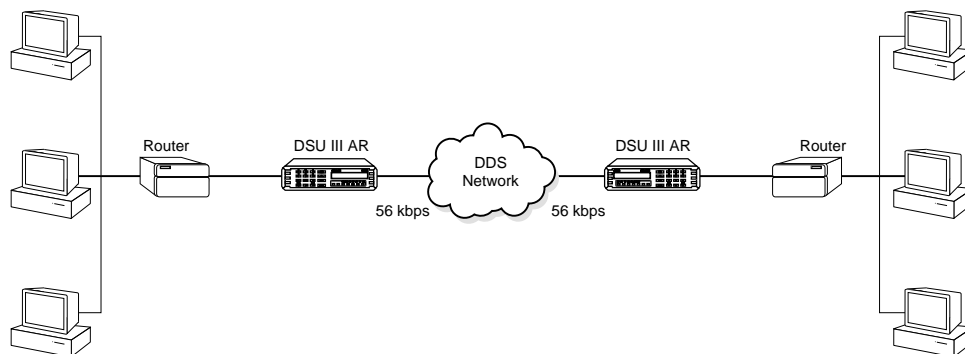

Figure 1-1. Sample Point-to-Point Application for DSU III AR

DDS Overview

Digital Data Service (DDS) is a nationwide service that allows interconnection and transport of data at speeds up to 64 kbps. The local exchange carriers provide the local loop service to DDS customers and may provide data for routing Inter-LATA to an interexchange carrier. In DDS mode, the DSU III AR supports all DDS service rates yielding DTE rates of 2.4, 4.8, 9.6, 19.2, 38.4 (sync or async), 56 and 64 kbps (synchronous). An additional rate of 57.6 kbps is available in async mode. At the DDS service rates of 56 kbps and 64 kbps, the unit can be configured to run slower DTE rates (async or sync). Secondary channel operation is supported at all service rates up to 56 kbps, providing terminal rates of 75, 150, 300, 600, 1200, and 2400 bps. The secondary rates available depend on the DDS service rate configured.

4-Wire Switched 56 Overview

This switched, 4-wire Digital Data Service allows customers to pay for data connection only for the time the unit is active. The regional operating companies provide the 4-wire local loop service to SW56 customers. In SW56 mode the DSU III AR supports DTE rates of 2.4, 4.8, 9.6, 19.2, 38.4 (asynchronous or synchronous) and 56 kbps (synchronous). An additional DTE rate of 57.6 kbps is available in asynchronous modes.

Chapter 2 Installation

UNPACK, INSPECT, POWER UP

Carefully inspect the DSU III AR for any shipping damages. If damage is suspected, file a claim immediately with the carrier and contact ADTRAN Customer Service. If possible, keep the original shipping container for use in shipping the DSU III AR for repair or for verification of damage during shipment.

ADTRAN Shipments Include

The following items are included in ADTRAN shipments of the DSU III AR:

- DSU III AR unit
- An 8-position modular to 8-position modular cable
- The DSU III AR User Manual

Customer Provides

- Male EIA-232 (standard 25-pin D-type), or
- Male V.35 interface cable.

Pinouts for the rear connectors are included in Appendix A, *Pinouts* on page A-1.

Power Up

Each DSU III AR unit is provided with a captive 8-foot power cord, terminated by a three-prong plug which connects to a grounded 115 VAC power receptacle. A telco connector is also provided for interface to the network.



Power to the DSU must be provided from a grounded 115 VAC, 60 Hz receptacle.

REAR PANEL

The rear panel contains three DTE connectors which provide primary channel V.35 or EIA-232, and a secondary channel EIA-232 port (auxiliary EIA-232). An 8-pin telco jack, a captive power cord, and a power switch are also located on the rear panel. Pin assignments for the DTE and network connections are listed in Appendix A, *Pinouts* on page A-1. The DSU III AR rear panel is shown in Figure 2-1.

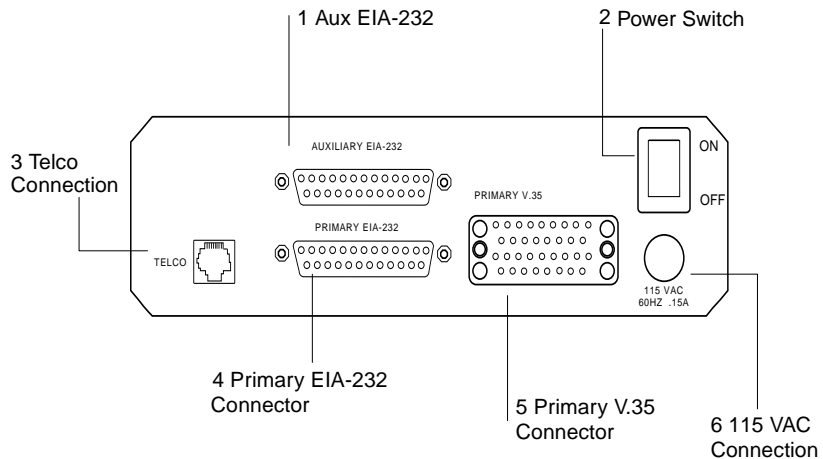

No.	Item	Function
1	Auxiliary EIA-232	Secondary channel services
2	Power Switch	Used to turn power on or off
3	Telco Connection	Connection to the dedicated circuit
4	Primary EIA-232	DTE interface
5	Primary V.35	High speed DTE interface
6	115 VAC Connection	Power cord connection

Figure 2-1. DSU III AR Rear View

Network Interface Connection

The DSU III AR has an eight-position modular jack labeled **TELCO**. The connector is used for connecting to the network when the unit is configured for either dedicated or switched operation. The pin assignments for the telco connector are listed in Table A-1 on page A-1.

DTE Data Connection/Primary DTE

The primary DTE rate is configured from the front panel. The primary DTE can operate in asynchronous or synchronous modes

The primary DTE should be connected to either the EIA-232 DTE connector or the CCITT V.35 DTE connector.

The maximum cable lengths recommended are 50 feet for the EIA-232. The pin assignments for the primary EIA-232 connector are shown in Table A-2 on page A-2. The EIA-232 connector works up to 56 kbps with a low capacitance cable or with the external transmit clock option selected.

For the CCITT V.35, the maximum cable lengths are 100 feet. The pin assignments for the V.35 are shown in Table A-3 on page A-3.

The V.35 connector is recommended for use with data rates above 19.2 kbps.



To prevent possible radio frequency interference emissions, a shielded cable is required.

Secondary Channel Connection

If used, the secondary DTE should be connected to the auxiliary EIA-232 connector. The pinout for the connector is shown in Table A-4 on page A-4.

Chapter 3 **Operation**

FRONT PANEL MENU STRUCTURE

The DSU III AR uses a multilevel menu approach to access its many features. All menu operations are displayed in the LCD window.

The opening menu is the access point for all other operations. There are four Main menu branches: Status, Test, Configuration and Dial.

Each main menu item has several functions and submenus to identify and access specific parameters.

Main Menu

The following paragraphs briefly describe the main menu's four branches, displayed on the front panel LCD (see Figure 3-1). Detailed information is provided in the individual chapters for each menu branch.

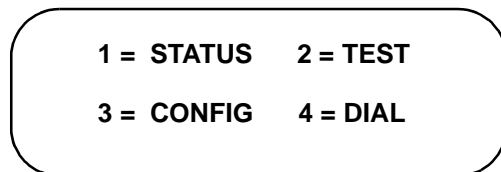

Figure 3-1. Main Menu LCD Display

Status

Status is used to display all relevant information for the network and DTE interfaces. It displays the current operating mode, loop status, rate of service from the network, DTE data rate and format, and TR, SR, LL, and RL DTE interface lead status. The display returns to the status menu when the front panel is not accessed. See Chapter 12, *Viewing Status Information* on page 12-1 for more detailed information.

Test

Test is used to control local and remote testing. Select local or remote testing, and select the type of test and test pattern when required. For more information see Chapter 7, *Configuring Test Options* on page 7-1.

Configuration (Config)

Configuration is used to select network and DTE operating parameters. This menu branch is divided into several chapters for easier reference. The division includes a brief overview chapter followed by a separate chapter for each of the five submenus of the CONFIG branch: *Network Configuration* on page 5-1, *Configuring DTE Options* on page 6-1, *Configuring Test Options* on page 7-1, *Configuring Dial Options* on page 8-1, and *Manual Command* on page 9-1.

Dial

Dial provides manual dialing functions. Key in a number to dial, select one of the ten stored numbers, or redial the last dialed number. This menu is available for use only when AT&T/MCI SW56 or US SPRINT SW56 is the selected network type. See Chapter 10, *Dial Selection* on page 10-1 for more information.

**NOTE**

The DIAL option is only available when the unit is configured for a Switched 56 network type. For more information, see Chapter 10, Dial Selection on page 10-1.

Basic Menu Travel

Four function keys on the left side of the DSU III AR keypad allow the various menu branches to be entered, exited, and scrolled through. The four function keys are defined below.

Enter

Selects a displayed item.

Up Arrow

Scrolls up the submenu items.

Down Arrow

Scrolls down the submenu items.

Cancel

Exits (back one level) from the current branch of the menu.

To choose a menu item, press the corresponding number or alpha character on the keypad (press **Shift** to activate alpha characters). The item flashes on and off to show it is the currently selected (active) choice. Press the up and down arrow keys to scroll through the available menu items. Press **Enter** to select the flashing item.

The following Step/Action Table and Figure 3-2 illustrate how to select the DSU III AR Loop Rate option.

Step	Action
1	To select CONFIGURATION (CONFIG) , press 3 ; then Enter .
2	To select LOCAL or REMOTE test, press the corresponding number; then press Enter .
3	Use the up and down arrows to view submenu items.
4	Choose an item on the submenu such as NETWORK OPTIONS (NETWORK OPT) .
5	Press 1 to select NETWORK OPT ; then press Enter .
6	Press 1 to select LOOP RATE options; then press Enter .
7	When the current network loop rate flashes, you can scroll up or down to view possible options.
8	To select a new loop rate, press the corresponding number; then press Enter .

			1=LOOP RATE
	1=LOCAL	1=NETWORK OPT.	2=NETWORK ADDR
3=CONFIG		2=DTE OPTIONS	3=REMOTE CONFIG.
	2=REMOTE	3=TEST OPTIONS	4=NETWORK TYPE
		4=DIAL OPTIONS	5=CLOCK SOURCE
		5=MANUAL COMMAND	

Figure 3-2. Example of Basic Menu Travel

FRONT PANEL

The DSU III AR faceplate is shown in Figure 3-3. Descriptions of each part of the front panel follow the figure.

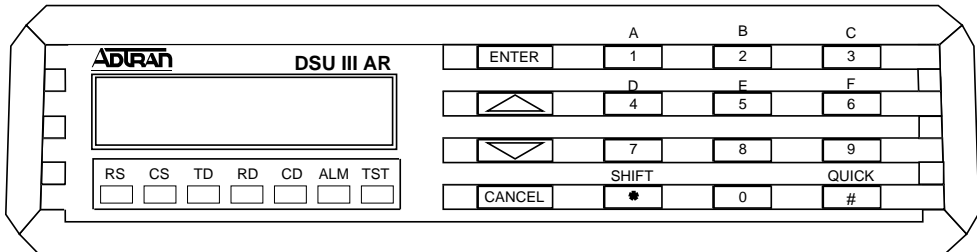

Figure 3-3. DSU III AR Front View

LCD Window

Displays menu items and messages in 2 lines by 16 characters.

Enter

Selects active menu items. To activate a menu item, press the number of the item. The menu item flashes, indicating it is the active selection. Press **Enter** to select the menu item.

Numeric Keypad

The numeric keypad contains the numbers 0 through 9 and alpha characters A through F, which are used to activate menu items and enter parameters.

Up and Down Arrows

Use the up and down arrows to scroll through the submenu items in the current menu. Submenu items appear two at a time in a circular or wrapping fashion. The submenu items are displayed in either a forward or reverse pattern.

Cancel

The **Cancel** key stops the current activity and returns to the previous menu. Repeat until the desired menu level is reached.

Shift

To enter alpha characters, press **Shift** before each desired character.

To activate a menu item designated by an alpha character rather than a number, press **Shift**, then the letter. The menu item flashes, indicating which parameter is activated. Press **Enter** to select the item.

If a key is pressed without using **Shift**, the numbered item becomes active instead of the alpha item.

Quick

During most operations, the **Quick** key returns the display to the main menu. During a test, the **Quick** key returns to the top of the Test menu. In SW56 operation, if the unit is not in test, the **Quick** key returns to the **DIAL** menu.

LED Descriptions

The DSU III AR has seven LED indicators, which are described below.

RS	REQUEST TO SEND
CS	CLEAR TO SEND
TD	TRANSMIT DATA
RD	RECEIVE DATA
CD	CARRIER DETECT
ALM	ALARM INDICATION
TST	TEST MODE MANUAL

Chapter 4 Configuration Overview

LOCAL AND REMOTE CONFIGURATION

The DSU III AR can be configured locally using the front panel or remotely by establishing communications with another DSU. The front panel of the local DSU can then be used to configure the remote DSU. During remote configuration, the DSU III AR prompts for the remote address before continuing to the **CONFIGURATION** (CONFIG) menus.

The **CONFIGURATION** menu consists of a group of five submenus relating to a specific interface or function of the DSU III AR that requires setup.

1=Network Opt.	Network Interface Parameters
2=DTE Options	DTE Interface Parameters
3=Test Options	Unit Test Options
4=Dial Options	Unit Dialing Options
5=Manual Command	ADTRAN Specific Commands

The DSU III AR contains four different user profiles (sets of configurations options) that are stored in read-only memory (see Appendix C, *Default Configuration Profiles* on page C-1). The unit is shipped from the factory with profile number 1 (default configuration) loaded into the current (nonvolatile configuration) memory. If profile 1 matches requirements for the system, then no

additional configuration is required to put the unit into service. If profile 1 does not match system requirements, it can be modified, or one of the other profiles that more closely matches the system requirements can be loaded into current memory. When a different profile is loaded, or the existing profile is modified, it is stored in the current (nonvolatile configuration) memory. The DSU III AR is then configured with that profile every time power is turned on or until the unit is reset.

For detailed information on configuration see Chapter 5, *Network Configuration* on page 5-1, Chapter 6, *Configuring DTE Options* on page 6-1, Chapter 7, *Configuring Test Options* on page 7-1, Chapter 8, *Configuring Dial Options* on page 8-1, and Chapter 9, *Manual Command* on page 9-1.

Configuration Methods

The DSU III AR responds to the following methods of configuration:

- VT-100 Compatible Terminal
- AT Commands
- V.25 Commands
- Front Panel Commands
- Remote Commands from another DSU running SLIP/PPP protocol.

The DSU III AR provides methods for both local and remote configuration. These methods are shown in Table 4-1.

Table 4-1. Configuration Methods

Method	Stand Alone	
	Local	Remote
AT Commands	Yes	Yes
V.25 Commands	Yes	Yes
Front Panel	Yes	Yes
DATAMATE	No	Yes
VT-100	Yes	Yes

A complete Configuration menu is shown in Figure 4-1; the Configuration menu tree with DTE options is shown in Figure 4-2 on page 4-4.

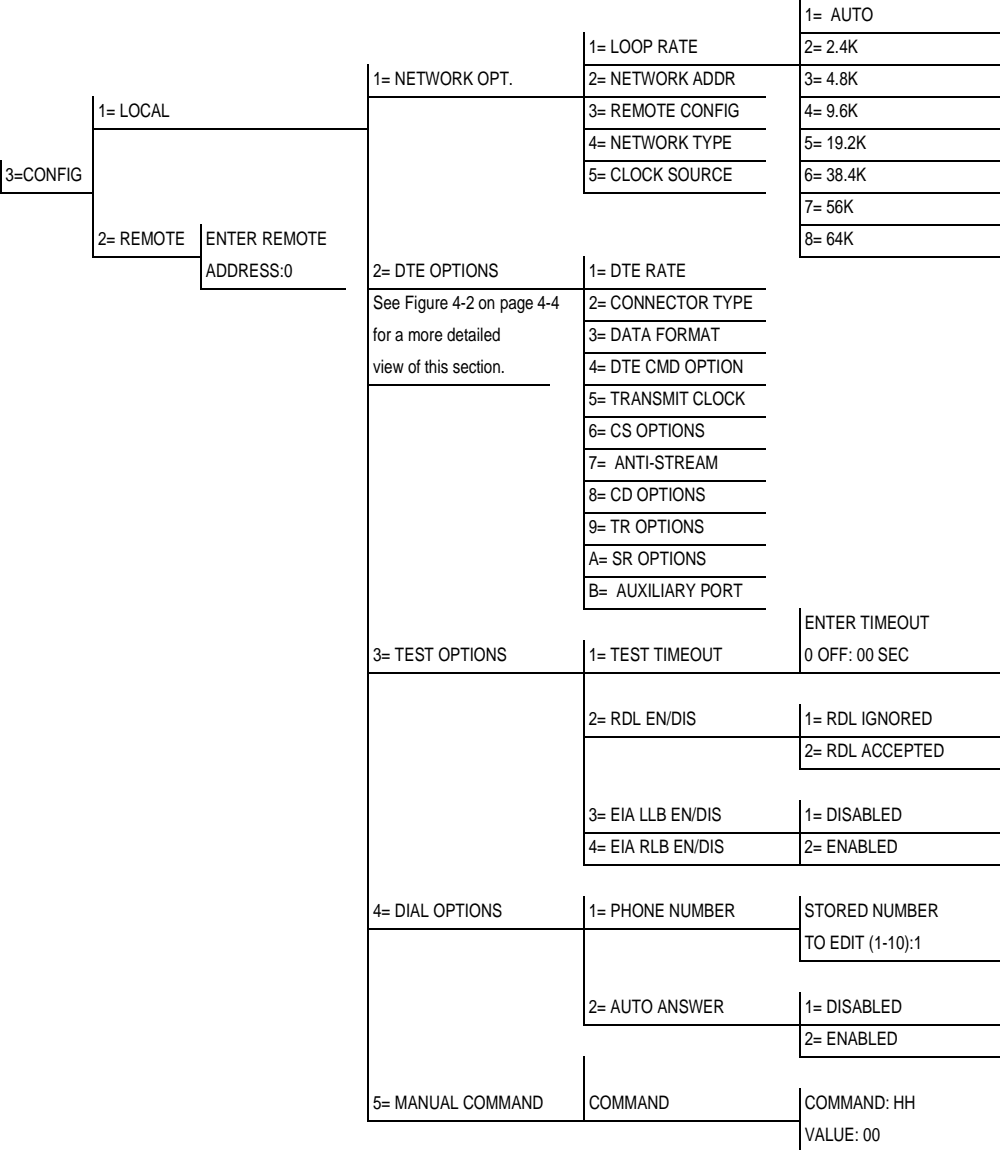

Figure 4-1. Complete Configuration Menu

2= DTE OPTIONS	1= DTE RATE	Options vary according to loop rate.	
	2= CONNECTOR TYPE	1= RS-232	
		2= V.35	
	3= DATA FORMAT	1= ASYNCHRONOUS	1= ASYNC 9 BITS
		2= SYNCHRONOUS	2= ASYNC 10 BITS
			3= ASYNC 11 BITS
	4= DTE CMD OPTION	1= DISABLED	
		2= AT COMMAND SET	
		3= V.25 SYNC	
		4= V.25 BSC/ASYNC	
5= TRANSMIT CLOCK		1= NORMAL	
		2= EXTERNAL	
6= CS OPTIONS	1= FORCED ON		
	2= FOLLOWS RS		
	3= FOLLOWS CD		
	4= FOLLOWS RS+ CD		
	5= OFF WITH LOCD	1= TIMER OFF	
7= ANTI-STREAM		2= TIME 10 SECONDS	
		3= TIME 30 SECONDS	
		4= TIME 60 SECONDS	
8= CD OPTIONS		1= FORCED ON	
		2= NORMAL	
		3= OFF WITH LOCD	
9= TR OPTIONS	1= IGNORED		
	2= IDLE WHEN OFF	1= FORCED ON	
	3= OFF>ON DIAL #1	2= OFF OOS ONLY	
	4= OFF>ON DIAL #2	3= OFF LOCD ONLY	
A= SR OPTIONS		4= OFF TEST ONLY	
		5= OFF TEST +OOS	
		6= OFF TEST + LOCD	
B= AUXILIARY PORT	1= EIA-232		
	2= V.35		

Figure 4-2. Configuration Menu with DTE Options

VT-100 Connection

The DSU III AR can be configured and controlled over a direct EIA-232 connection to the Auxiliary Port located on the back of the unit. To set up the DSU III AR for a VT-100 terminal session, the following steps are required:

Step **Action**

1. From the front panel set the connection baud rate. Follow the menu below to display the appropriate configuration parameters. Select one of the **CONTROL** baud rates.

3= CONFIG	1= LOCAL	2= DTE OPTIONS	1= DTE RATE	
			2= CONNECTOR TYPE	
			3= DATA FORMAT	1= 1.2K AT_CMD
	2=REMOTE	ENTER ADDRESS	4= DTE CMD OPTION	2= 75 SEC
			5=TRANSMIT CLOCK	3= 150 SEC
			6= CS OPTIONS	4= 300 SEC
			7= ANTI-STREAM	5= 600 SEC
			8= CD OPTIONS	6= 1.2K SEC
			9= TR OPTIONS	7= 2.4K SEC
			A= SR OPTIONS	8= OFF
			B= AUXILIARY PORT	9= 300 CONTROL
				A= 1.2K CONTROL
				B= 2.4K CONTROL
				C= 9.6K CONTROL

2. After the baud rate is selected, a passcode prompt is displayed. Enter the desired passcode, or press **Enter** to accept the 123 default.
3. Configure the VT-100 emulator with the appropriate baud rate, **8 DATA BITS, No PARITY BITS, 1 STOP BIT, and No FLOW** control (8N1). Refer to the VT-100 emulator documentation for details on configuration.
4. Connect the VT-100 terminal to the female RS-232 connector, labeled **AUXILIARY PORT**, located on the back of the unit.
5. Press **<Enter>** on the VT-100 terminal and a passcode prompt is displayed. Enter the passcode from step 2.

AT Commands

The DSU III AR can be configured and controlled with in-band AT commands from an asynchronous DTE port just as modems are.

To exit the data mode and enter the command mode, the asynchronous DTE device must transmit a proper escape sequence or three pluses (+++) to the DSU III AR. A specified time delay must occur between the last data character and the first escape sequence character. This is the guard time delay, and it can be changed by writing a value to the S12 register. The default value for the guard time is one second. For a valid escape sequence to occur, the DTE must transmit the escape code character three times in succession with delay between each character being less than the guard time.

Once the command mode is entered, AT commands can be transmitted to the DSU III AR to configure most of the options or initiate tests to check both the DSU III AR and the network connections. All command lines must begin with the AT attention code in either capital or lower case letters. The command that follows must match the case of the attention code.

The command line may contain a single command or a series of commands after the AT attention code. When a series of commands is used, the individual commands may be separated with spaces for readability. The maximum length for a command line is 40 characters. Each command line is executed by the DSU III AR upon receipt of a terminating character. The default terminating character is a carriage return (ASCII 013), but it can be changed by writing a different value to register S3.

Before the terminating character is transmitted, the command line can be edited by using the backspace character (ASCII 008) to erase errors so the proper commands can be entered.

Valid AT commands for the DSU III AR are listed in Appendix B, *AT Commands* on page B-1.

V.25 Bis Commands

When configured for the V.25 bis option, the DSU III AR accepts in-band dialing and configuration commands from both synchronous and asynchronous DTE ports.

The V.25 bis option supports the following protocols:

- SDLC (Synchronous Data Link Control)
- BI-SYNC
- ASYNCHRONOUS

SDLC Option

Character Format

- Data bits - 8
- Parity bit - Ignored

Command Structure

```
[F][A][C][V.25 bis COMMAND][FCS][F]
```

The address field [A] is FFH. The control field [C] is set to 13H except for cases of multi-frame responses. For this case, the control field is set to 03H in all but the last frame. The 03H in the control field indicates that other frames are to follow while the 13H in the control field indicates the final frame.

Bi-Sync Option

Character Format

- Data bits - 7
- Parity bit - Odd

Command Structure

```
[SYN][SYN][STX][V.25 bis COMMAND][ETX]
```

Asynchronous Option

Character Format

Start bit - 1
Data bits - 7
Parity bit - Even
Stop bit - 1

Command Structure

```
[V.25 bis COMMAND][CR][LF]
```

Command Descriptions

The ADTRAN V.25 bis command set is a subset of the CCITT V.25 bis command set. In addition to the CCITT commands supported, ADTRAN has added configuration commands for both local and remote DSUs.

The ADTRAN V.25 bis command set follows:

CIC	Connect incoming call
CNL	Configuration local
CNR	Configuration remote
CRN	Call request with number
CRS	Call request using stored number
DIC	Disregard incoming call
PRN	Program number
RLN	Request list of numbers

The following list contains possible responses to V.25 bis commands:

VAL	Valid V.25 command processed
CFIET	Call failed on switched network - busy detected
CFIDE	Call failed on switched network - no wink detected
CFINS	Call failed - no dial string in specified register
INVCU	Unknown command detected
INVPS	Invalid parameter syntax
INVPV	Invalid parameter value
INVBL	Invalid local password
INVBM	Invalid remote password
INC	Incoming call
CNX	Call connected

If verbose responses are disabled (ATV0), the following list of three-character responses are the only ones returned:

VAL	Valid V.25 command processed
INV	Invalid command received
CFI	Call failed
INC	Incoming call
CNX	Call connected

Syntax and Possible Responses

CIC (Connect Incoming Call)

This command causes the DSU to go on-line. For dial backup units, this command hangs up the dial backup line and initiates an attempt to reestablish the main (DDS) line. There are no parameters associated with this command. Possible indications include VAL, CNX, and CFIdx.

CNL (Configuration Local)

This command is used to pass AT commands to the local modem via the V.25 bis command processor. This allows the DSU III AR to be configured with AT commands via a synchronous interface. The command has the following format:

```
CNL[LOCAL PASSWORD;]AT[ONE OR MORE AT COMMANDS]
```

A local password may not be required, depending on the present configuration of the unit. Responses to CNL commands are returned in the data format currently configured. Possible responses include VAL and INVn.

CNR (Configuration Remote)

This command is used to pass AT commands over the network to the remote DSU via the V.25 bis command processor. This allows a remote DSU III AR to be configured from a synchronous interface. The command's format is as follows:

```
CNR[REMOTE PASSWORD;]AT[ONE OR MORE AT COMMANDS]
```

The remote password may or may not be required depending on the present configuration of the remote unit. Responses to the CNR commands are returned in the data format currently configured. Possible responses include VAL and INVn.

Switched 56 Operation**CRN (Call Request with Number)**

When the DSU III AR is configured for SW56 operation, the CRN command causes the DSU to dial the supplied number. The command's format follows:

```
CRN[NUMBER TO BE DIALED]
```

If no number is included in the command, the number stored in dial register number 1 is dialed. If no number is provided and no number is stored in dial register number 1, the DSU III AR responds with the call failure indication CFINS (Call Failure Indication Not Stored).

For a DBU unit, this command initiates dialing on the backup circuit. If the number supplied contains non-dialable digits, they

are ignored and only the dialable digits are dialed. Possible responses include VAL, CNX, and CFIXx.

CRS (Call Request Using Stored Number)

The CRS command causes the DSU III AR to dial the number stored in the specified register. The format of this command is as follows:

```
CRS [OPTIONAL SPACE][REGISTER NUMBER 1-10]
```

If this command is issued without the register number parameter, the INVPS (Invalid Parameter Syntax) response is issued. If this command is issued and the register parameter is not in the valid range for dialing registers, the INVPV (Invalid Parameter Value) response is returned. Other responses include VAL, CNX, and CFIXx.

DIC(Disregard Incoming Call)

This command causes the V.25 bis processor to return to command mode even if there is an incoming call pending. This allows local commands to be issued and incoming calls to be ignored. There are no parameters associated with this command. The DSU responds with VAL.

PRN (Program Number)

This command stores the supplied number into the specified register. The command has the following format:

```
PRN REGISTER NUMBER;[NUMBER TO BE STORED]
```

If this command is entered with no parameters, the INVPS response is returned. If no register number is included in the command or if it is invalid, the INVPV response is returned. This response is also returned if the number to be stored contains invalid characters. The characters 1, 2, 3, 4, 5, 6, 7, 8, 9, 0, P, T, and & are valid dial characters. If no digits are issued with this command, the specified register is cleared. The DSU responds with VAL.

RLN (Request List of Numbers)

This command causes the DSU III AR to return the number stored in the specified register. The format of this command follows:

```
RLN [REGISTER NUMBER]
```

If the register number is invalid, the INV PV response is returned. When a correct register number is entered, the following response is returned:

```
LSN [REGISTER NUMBER]; [NUMBER STORED]VAL
```

If no register number is present in the command, the DSU III AR responds with a list of all the registers and the stored numbers. This list is followed by the VAL response.

Chapter 5 Network Configuration

NETWORK OPTIONS

The **NETWORK OPTIONS** configuration parameters control the loop operation of the DSU III AR.

Once a parameter is set, **COMMAND ACCEPTED** is displayed briefly before returning to the active menu.

Loop Rate

The Loop Rate option sets the loop operating speed. The unit should be set to the rate required by the DDS Service. The DSU III AR also supports subrate DTE data over a 56 kbps or 64 kbps loop. The loop rate must be set independently of the DTE rate.

The default factory setting is **AUTO**. When configured to **AUTO**, the DSU will automatically attempt to adapt to the loop rate. Since 64k and 56k secondary channels look identical on the network, the DSU III will adapt to 56k secondary channel for either loop rate. If the loop rate is known, select the rate from the menu. The various loop rates and format selections are listed in Figure 5-1 on page 5-2. The equivalent AT commands that perform the same configuration functions are shown in Table 5-1 on page 5-2.

Eight loop rate selections are available (shown in Figure 5-1). After selecting any loop rate other than **AUTO** or **64 KBPS** the option for a secondary channel is available. The secondary channel rate is determined by the current loop rate.

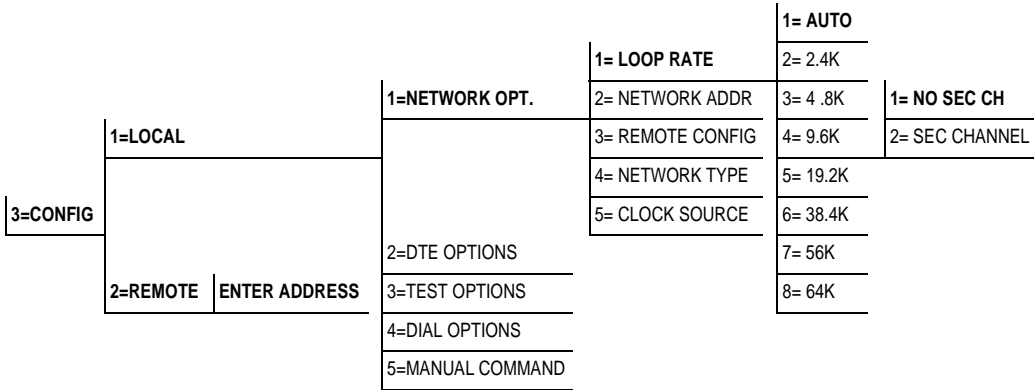

Figure 5-1. Setting Loop Rate Options

Table 5-1. Loop Rate Commands

Front Panel	AT Command
AUTO	%B0
2.4K with no secondary channel	%B1
4.8K with no secondary channel	%B2
9.6K with no secondary channel	%B3
19.2K with no secondary channel	%B4
38.4K with no secondary channel	%B5
56K with no secondary channel	%B6
64K clear channel	%B7
2.4K with secondary channel	%B9
4.8K with secondary channel	%B10
9.6K with secondary channel	%B11
19.2K with secondary channel	%B12
38.4K with secondary channel	%B13
56K with secondary channel	%B14

Network Address

A two-digit decimal address can be assigned to each DSU III AR. This addressing capability makes it possible to perform remote configuration and testing in point-to-point and multi-drop networks. Figure 5-2 shows the menu path used to change the network address. The factory default address setting is 0. Table 5-2 shows the AT commands used to set the network address.

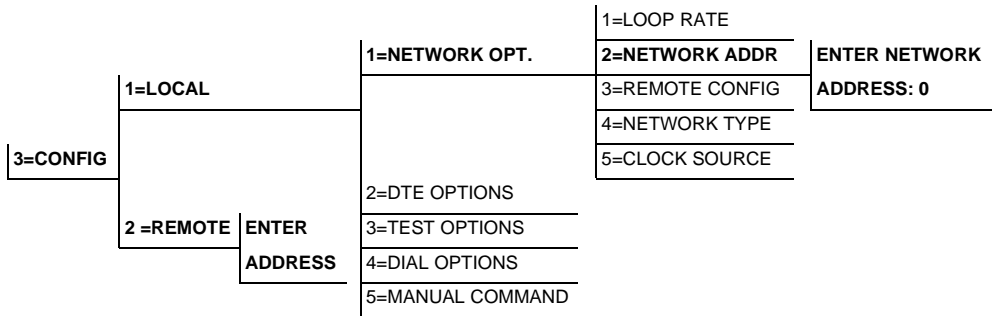

Figure 5-2. Setting the Network Address

Table 5-2. Network Address Command

Front Panel	AT Command	Description
XX (Decimal)	_N=xx	Assigns a 2-digit Network Address

Remote Configuration

This option sets up the DSU III AR to accept or reject remote configuration commands. Figure 5-3 shows the menu path for enabling/disabling remote configuration. The factory default setting is **ENABLED**.

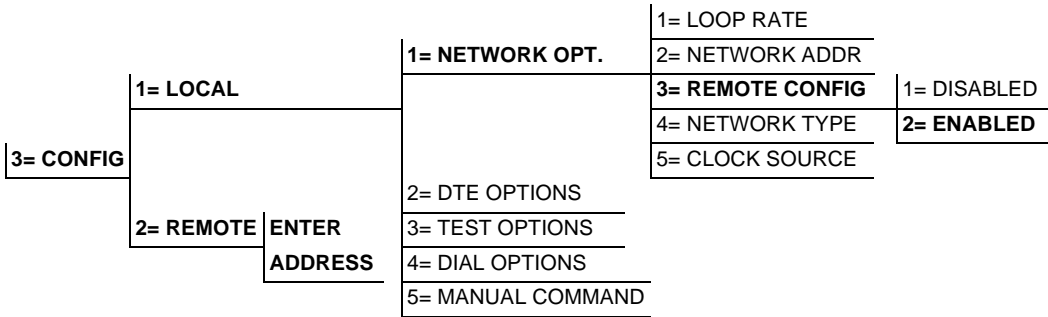

Figure 5-3. Enabling/Disabling Remote Configuration

Table 5-3 shows the equivalent AT commands used to enable or disable remote configuration.

Table 5-3. Remote Configuration Commands

Front Panel	AT Command	Description
1=DISABLE	&P4	Disable Remote Configuration
2=ENABLE	&P5	Enable Remote Configuration

Network Type

This option configures the DSU III AR for the specific type of network being used. The choices are **DEDICATED**, **AT&T/MCI SW56**, and **US SPRINT SW56**. The factory default setting is **DEDICATED** (see Figure 5-4).

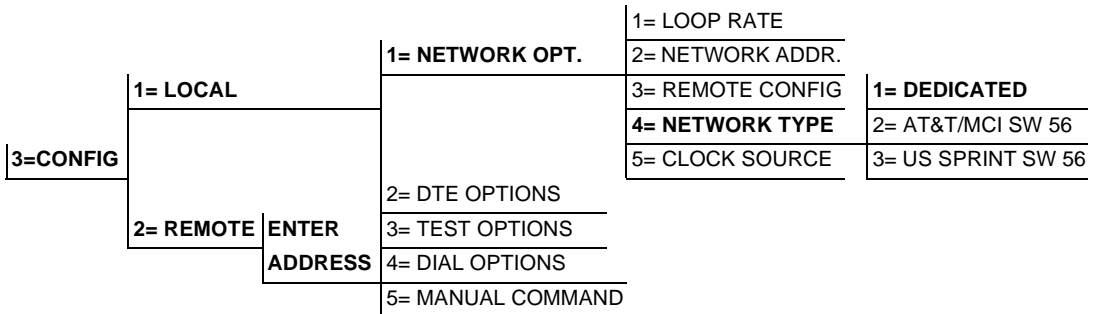

Figure 5-4. Setting Network Type Options

When **AT&T/MCI SW56** or **US SPRINT SW56** is selected, the Main menu displays the **DIAL** selection.

Table 5-4 shows the equivalent AT commands that perform the same configuration functions.

Table 5-4. Network Type Commands

Front Panel	AT Command	Description
1=DEDICATED	&L0	Any 4-wire DDS Network
2=AT&T/MCI	&L1	AT&T/MCI Switched 56 Service
3=US SPRINT	&L2	US SPRINT Switched 56 Service

Clock Source

The **CLOCK SOURCE** options specify the timing source for the DSU III AR internal circuitry. The choices are **FROM NETWORK** and **MASTER**. The factory default setting is **FROM NETWORK** (see Figure 5-5).

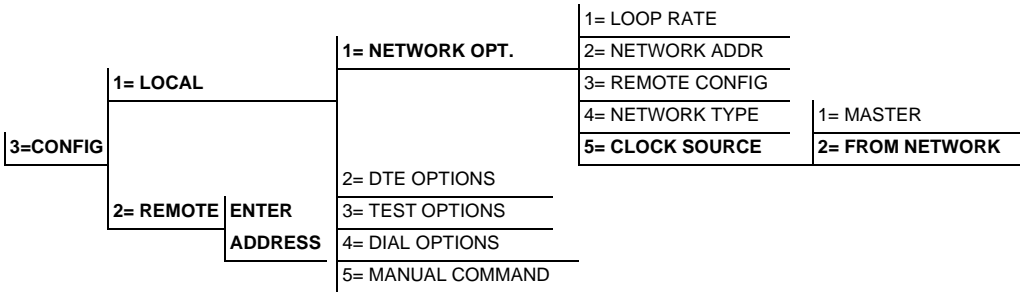

Figure 5-5. Setting the Clock Source

When operating on a DDS network, the timing should be from the most stable clock source, usually **FROM NETWORK**. On a point-to-point private network, one DSU III AR must be set for **MASTER** and the other set for **FROM NETWORK**. Table 5-5 shows the equivalent AT commands for setting the clock source.

When the DSU III AR is set as the master clock source, it will default to its internal oscillator as the clock reference. To enable the External DTE port as the reference clock for the circuit, see Chapter 6, *Configuring DTE Options* on page 6-1.

Table 5-5. Setting the Clock Source

Front Panel	AT Command	Description
1=MASTER	_X0	DSU is the master timing source
2=FROM NETWORK	_X1	Network RX Signal is timing source

Chapter 6 **Configuring DTE Options**

DTE OPTIONS

The **DTE OPTIONS** menu is used to select the configuration parameters that control the operation of the DSU III AR's DTE Interface such as the DTE rate, connector type, data format, DTE command options, transmit clock, CS options, anti-stream, and CD options.

DTE Rate

The selectable DTE rates over a 56 or 64 kbps loop with no secondary channel are shown in Figure 6-1. If a slower loop rate is selected, then the DTE rate automatically matches the loop rate. If an attempt is made to set the DTE rate for loop rates slower than 56 kbps, the DSU III AR briefly displays **DTE RATE SAME AS THE NETWORK** before returning to the status screen. The factory default setting is **SAME AS LOOP**.

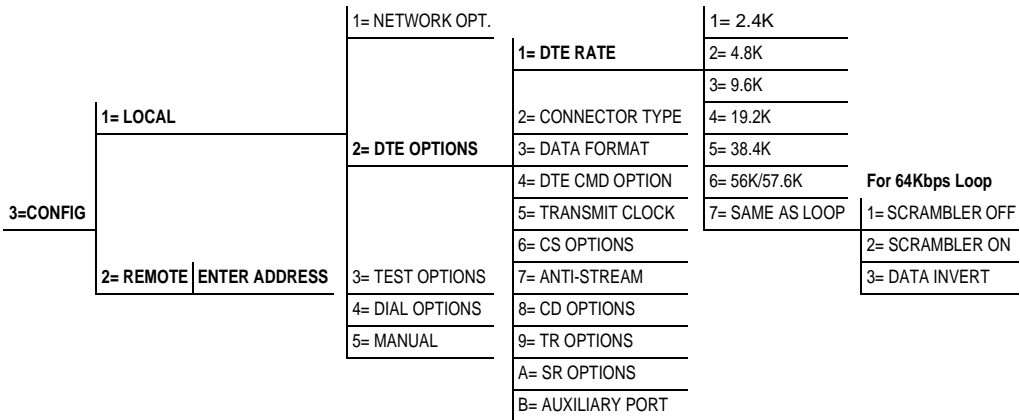

Figure 6-1. DTE Rates for 56 or 64 kbps Loop Rate with No Secondary Channel

The equivalent AT commands for setting the DTE rate for a 56 kbps loop rate with no secondary channel are shown in Table 6-1.

Table 6-1. DTE Rate AT Commands

Front Panel	AT Command	Description
1=DTE 2.4K	%K3	DTE rate 2.4K sync and async
2=DTE 4.8K	%K4	DTE rate 4.8K sync and async
3=DTE 9.6K	%K5	DTE rate 9.6K sync and async
4=DTE 19.2K	%K6	DTE rate 19.2K sync and async
5=DTE 38.4K	%K7	DTE rate 38.4K sync and async
6=DTE 56K/57.6K	%K8	DTE rate 56K sync or 57.6K async
7=SAME AS LOOP	%K9	DTE rate same as loop speed

If the DSU III AR is set for a loop rate of 56 kbps with secondary channel, then **SCRAMBLER ON/OFF** options are available as shown in Figure 6-2. The factory default setting is **SCRAMBLER OFF**.

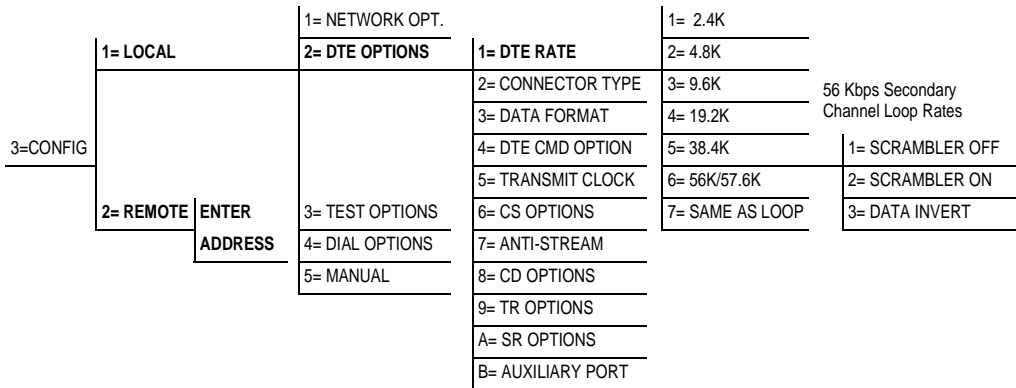

Figure 6-2. DTE Rates for 56 kbps Secondary Channel and 64 kbps Loop Rates

Table 6-2 shows the equivalent AT commands for setting **SCRAMBLER ON/OFF** for loop rates of 56 kbps with secondary channel and 64 kbps.

Table 6-2. Scrambler On/Off AT Commands

Front Panel	AT Command	Description
1=SCRAMBLER OFF	_F0	DTE data scrambler disabled
2=SCRAMBLER ON	_F1	DTE data scrambler enabled
3=DATA INVERT	_F2	DTE data invert enabled (56 kbps secondary channel Loop Rate only). LBE codes from DTE suppressed (64 kbps only).



*For point-to-point operation at 56 kbps with secondary channel, the network requires that the primary and secondary channel data not be all zeros simultaneously. For HDLC protocol applications, this constraint can be eliminated by selecting either the **DATA INVERT** option or the **SCRAMBLER ON** option. The factory default setting is **SCRAMBLER OFF**.*



*For 64 kbps clear channel operation, there is a possibility that the DTE data sequences might mimic network loop maintenance functions and erroneously cause other network elements to activate loopbacks. To prevent this, the **SCRAMBLER ON** or **SUPPRESS LBE** option should be selected for both the local and remote DSU III AR.*

Connector Type

The **CONNECTOR TYPE** option is used to specify which of the primary channel connectors is used to connect to the DTE. Figure 6-3 shows the menu path used to set the connector type. The factory default setting is V.35. There are no AT commands available to set the connector type.

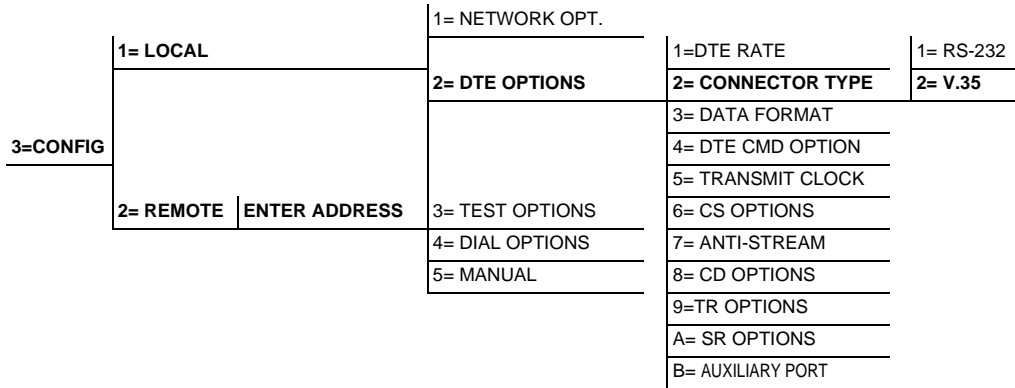

Figure 6-3. Selecting the Connector Type

Data Format

The **DATA FORMAT** option is used to select either the **SYNCHRONOUS** or **ASYNCHRONOUS** mode of operation for the DTE interface. The factory default setting is **SYNCHRONOUS** (see Figure 6-4). If **ASYNCHRONOUS** is chosen, the length of the data bytes must be selected.

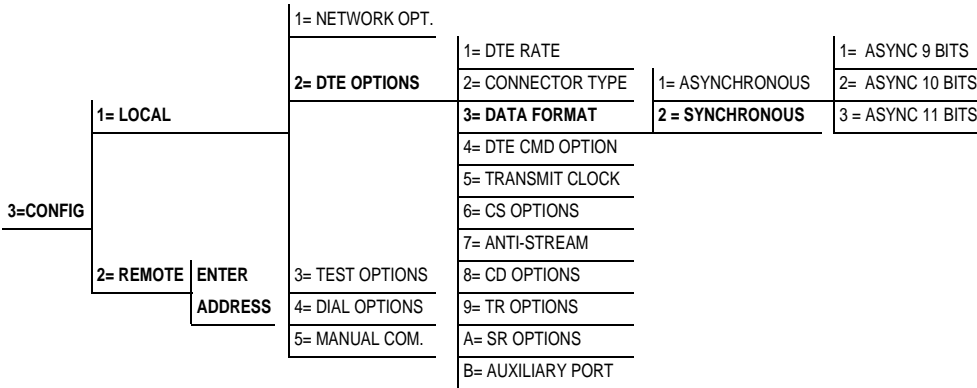

Figure 6-4. Selecting Asynchronous or Synchronous Data Format

Table 6-3 shows the AT commands that can be used to set the **DATA FORMAT**.

Table 6-3. Data Format Commands

Front Panel	AT Command	Description
1=ASYNCHRONOUS	&Q0	Always asynchronous
2=SYNCHRONOUS	&Q2	Always synchronous
For asynchronous options, select the length of the data bytes.		
1=ASYNC 9 BITS	N/A	9 bits including start, stop, parity
2=ASYNC 10 BITS	N/A	10 bits including start, stop, parity
3=ASYNC 11 BITS	N/A	11 bits including start, stop, parity

DTE Command Option

The **DTE COMMAND** option is used to enable AT commands from the DTE, enable V.25 bis SDLC (Synchronous Data Link Control) commands, enable V.25 (Bisync and Async), or disable all DTE command modes (see Figure 6-5).

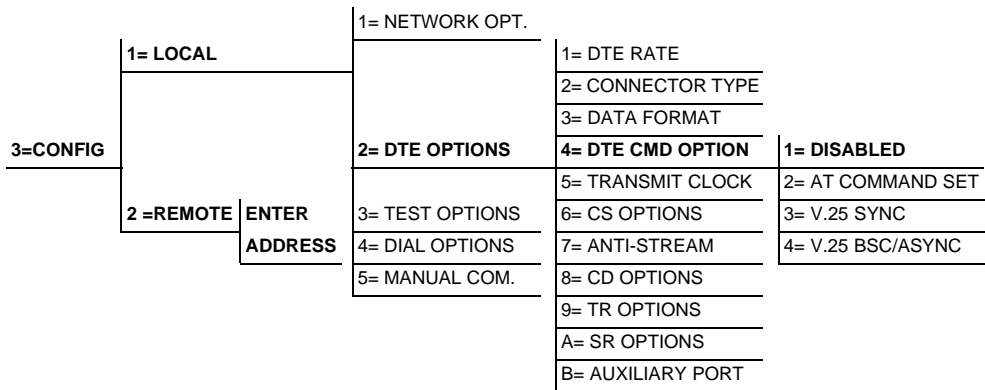

Figure 6-5. Selecting DTE Command Option



NOTE

When the unit is in **DTE CMD OPTION** mode (idle in **SW56** mode, forced with **TR** option, or from escape sequence in **AT** mode) with **AT COMMAND SET** or **V.25 SYNC** selected, the **DTE** format is independent of the **DATA FORMAT** option. However, if **V.25 BSC/ASYNC** is selected, the unit will use **V.25 BISYNC (BSC)** commands for synchronous data format or **V.25 ASYNC** commands for asynchronous data format.

Transmit Clock

The **TRANSMIT CLOCK** option is used to select the source of the clock used to transfer data from the DTE into the DSU III AR. Figure 6-6 shows the menu path used to set the **TRANSMIT CLOCK** option. The factory default is **NORMAL**.

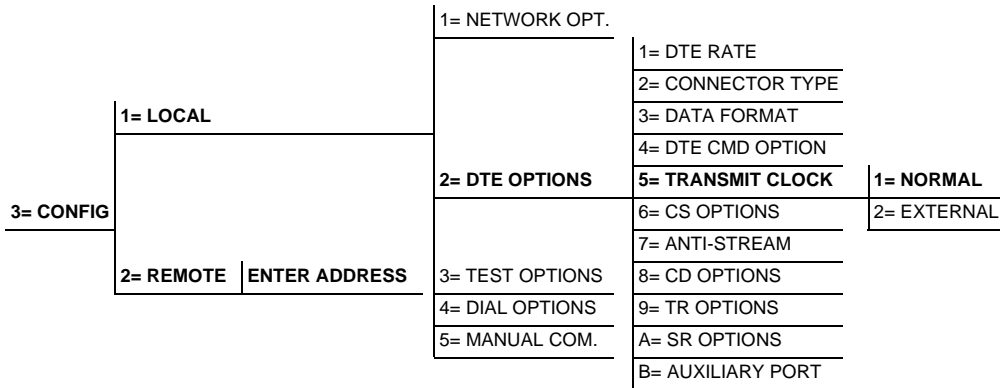

Figure 6-6. Transmit Clock Options

Table 6-4 shows the AT commands used to set the **TRANSMIT CLOCK** option.

Table 6-4. Transmit Clock AT Commands

Front Panel	AT Command	Description
1=NORMAL	&X0	TX clock from DSU selected
2=EXTERNAL	&X1	ETC clock from DTE selected

The **EXTERNAL CLOCK** option allows the DSU III AR to accept **MASTER CLOCK** timing from the External DTE Port as defined under DTE Options connector type. The **CLOCK SOURCE** under **NETWORK OPTIONS** must also be set to **MASTER** as noted in *Network Configuration* on page 5-1.

The **EXTERNAL CLOCK** option is normally used in modem tail circuit applications. See Appendix E, *DSU to DSU Tail Circuit* on page E-1 for information about the DSU to modem interconnect diagram for this application.

The **EXTERNAL CLOCK** option is also recommended when the **EIA-232** connector is used for 56 kbps and 64 kbps applications. A special DSU cable diagram for this application is shown in Appendix D, *EIA-232 Connector* on page D-1. Using this option and special cable eliminates data errors caused by excessive delays in the DTE transmit clock receiver and transmit data driver.

CS Options

The **CLEAR TO SEND (CS OPTIONS)** menu is used to select one of five different control modes for the CS lead. Figure 6-7 shows the menu path used to access the **CS OPTIONS** menu. The default factory setting is **FOLLOWS RS** with **CS DELAY SHORT**.

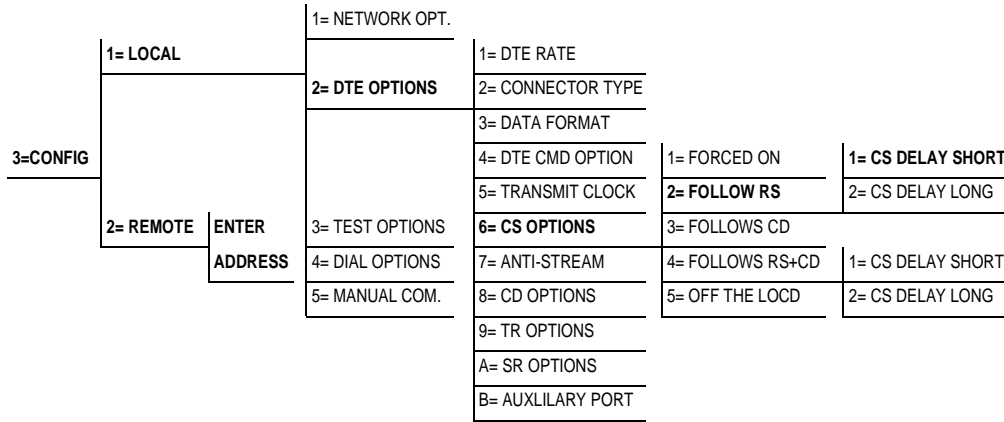

Figure 6-7. Selecting CS Options

If one of the options chosen involves request to send (RS), then the delay from RS to CS must be selected. Table 6-5 on page 6-11 shows the **AT COMMANDS** used to set the **CS OPTIONS**.

Table 6-5. CS Options AT Commands

Front Panel	AT Command	Description
1=FORCED ON	&R0	CS always on.
2=FOLLOWS RS	&R1	CS on with RS after delay; off when RS or if DSU cannot pass data.
3=FOLLOWS CD	&R2	CS off when CD goes off or if DSU cannot pass data.
4=FOLLOWS RS+CD	&R3	CS follows RS after delay and also off if CD off. If CD goes off after RS is on, DSU III AR will turn off CS but continue to pass data until RS goes off. CS also off if DSU cannot pass data.
5=OFF WITH LOCD	&R4	Off 5 sec after LOCD. Valid only in SW56 mode. CS is forced on but will turn off for 5 seconds after a call is disconnected.
For RS options, select the RS to CS delay length.		
1=CS DELAY SHORT	_D0	Short Delay from RS to CS selected.
2=CS DELAY LONG	_D1	Long Delay from RS to CS selected.

Specified times for the short and long delays at the different operating speeds are shown in Table 6-6.

Table 6-6. Short and Long Delays at Different Operating Speeds

Rate	Short Option	Long Option	Tolerance	Add to Maximum Time for Secondary Channel
64K	1.1ms	16.1ms	±.4ms	
56K	1.1ms	16.1ms	±.4ms	.33ms
38.4K	1.5ms	16.5ms	±.4ms	.63ms
19.2K	1.5ms	16.5ms	±.4ms	1.25ms
9.6K	1.5ms	16.5ms	±.4ms	2.5ms
4.8K	1.9ms	16.9ms	±.7ms	5.0ms
2.4K	3.8ms	18.8ms	±1.3ms	10.0ms

Anti-Stream

The **ANTI-STREAM** option is used to select the anti-stream time-out. The anti-stream time-out is the maximum time the DSU III AR transmits data into the network from the DTE. This feature prevents one DTE device on a multi-drop network from continuously tying up the transmit circuit back to the master DSU. Figure 6-8 shows the menu path used to access the **ANTI-STREAM** options menu.

The anti-stream timer is reset to zero when RS changes to the active state and is updated every second while RS is active. When the anti-stream time-out expires, the DSU III AR stops transmitting DTE data into the network but continues to accept data from it. This condition exists until the DTE deactivates the RS input.

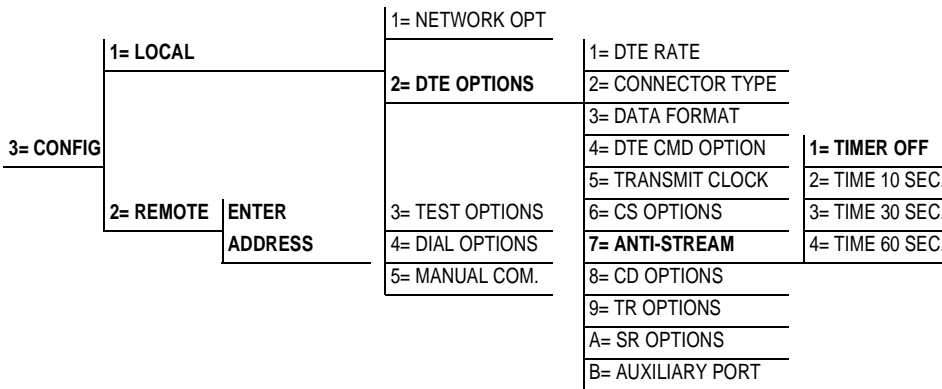

Figure 6-8. Anti-Stream Options

The factory default setting is **TIMER OFF**. Table 6-7 shows the available options and their AT commands.

Table 6-7. Anti-Stream AT Commands

Front Panel	AT Command	Description
1=TIMER OFF	%T0	Anti-stream timer disabled
2=TIME 10 SEC.	%T1	Time-out equal 10 seconds
3=TIME 30 SEC.	%T2	Time-out equal 30 seconds
4=TIME 60 SEC.	%T3	Time-out equal 60 seconds

Carrier Detect (CD) Options

The **CARRIER DETECT (CD) OPTIONS** menu is used to select one of three different control modes for the receive line signal detector (CD) lead. The default factory setting is **NORMAL** (see Figure 6-9).

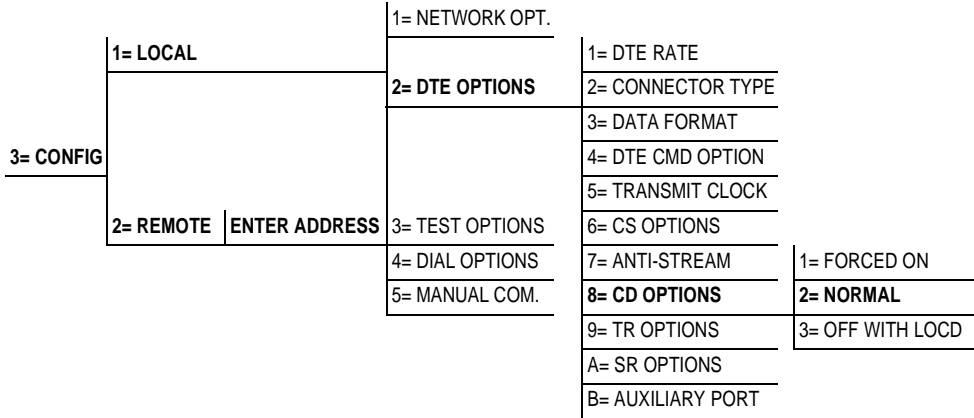

Figure 6-9. Selecting CD Options

Table 6-8 shows the equivalent AT commands for setting CD options.

Table 6-8. CD Options AT Commands

Front Panel	AT Command	Description
1=FORCED ON	&C0	On all the time
2=NORMAL	&C1	On only when data present on loop.
3=OFF WITH LOCD	&C2	On except after disconnect in Switched 56 application

TR Options

The **TR OPTIONS** menu is used to select the DSU III AR response to the data terminal ready (TR) lead. The factory default setting is **IGNORED** (see Figure 6-10).

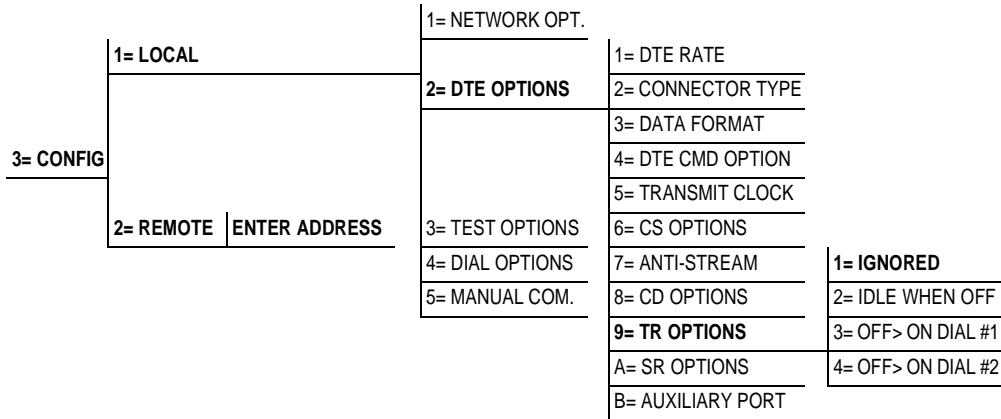

Figure 6-10. Selecting TR Options

Table 6-9 shows the equivalent AT commands for setting **TR OPTIONS**.

Table 6-9. TR Options AT Commands

Front Panel	AT Command	Description
1=IGNORE	&D0	Ignore the TR input.
2=IDLE WHEN OFF	&D2	See the following note.
3=OFF>ON DIAL #1	&D3	Dial Stored #1: TR goes off to on (SW56 only).
4=OFF>ON DIAL #2	&D4	Dial Stored #2: TR goes off to on (SW56 only).

NOTE *For **IDLE WHEN OFF** option: In SW56 mode, TR off will cause the DSU to go On Hook (Idle). The unit also will not dial out if TR is off. In dedicated mode, the DSU will go into DTE command mode when TR goes off. When TR goes on, if the DSU does not receive a command in the number of seconds set in S40, the DSU will go into data mode.*

SR Options

The **SR OPTIONS** menu is used to select the operating mode for the data set ready (SR) lead. From the DTE options menu, press **Shift + A** to activate the **SR OPTIONS** submenu; then press **ENTER** to select. The factory default setting is **OFF TEST ONLY** (see Figure 6-11).

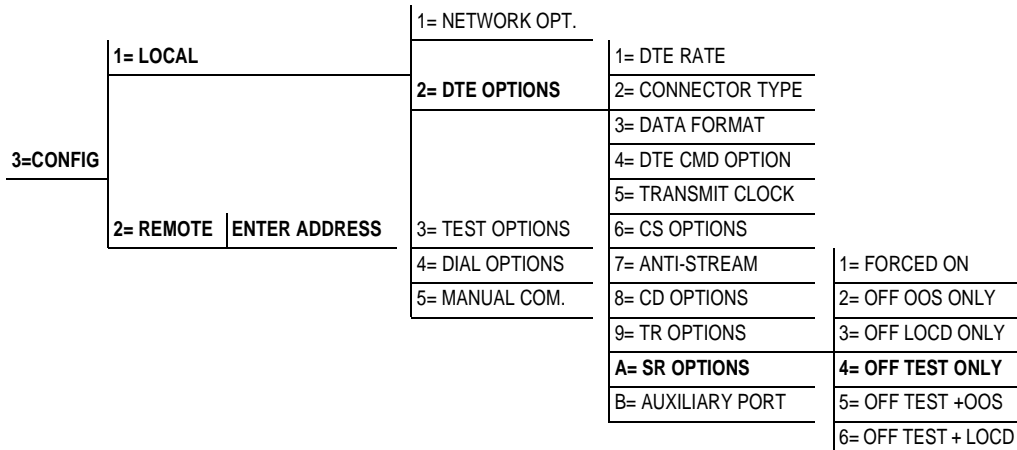

Figure 6-11. Setting SR Options

Table 6-10 shows the AT commands for setting **SR OPTIONS**.

Table 6-10. SR Options AT Commands

Front Panel	AT Command	Description
1=FORCED ON	&S0	Always on
2=OFF OOS ONLY	&S1	Off when network Out Of Service (OOS)
3=OFF LOCD ONLY	&S3	Off 5 seconds after disconnect (SW56 only)
4=OFF TEST ONLY	&S0_C0	Off when unit is in test
5=OFF TEST +OOS	&S1_C0	Off in test or OOS
6=OFF TEST +LOCD	&S5	Off 5 seconds after disconnect or test

Auxiliary Port

The **AUXILIARY PORT** option is used to select the operating speed for the secondary channel if the secondary channel option was selected during setup of the **NETWORK OPTIONS** (see Figure 6-12). From the DTE options menu, press **Shift + B** to activate the **AUXILIARY PORT** submenu and press **Enter** to select. The factory default is **OFF**.

The **AUXILIARY PORT** has an internal 256 byte buffer. If the secondary channel speed is higher than the throughput in the network, CTS flow control is activated. If the secondary DTE does not respond to CTS flow control, care should be taken to prevent the **AUXILIARY PORT** internal buffer from overflowing. The **AUXILIARY PORT** option may also be used to provide VT-100 menu access through the EIA-232 interface. For more details on this option, refer to *VT-100 Connection* on page 4-5.

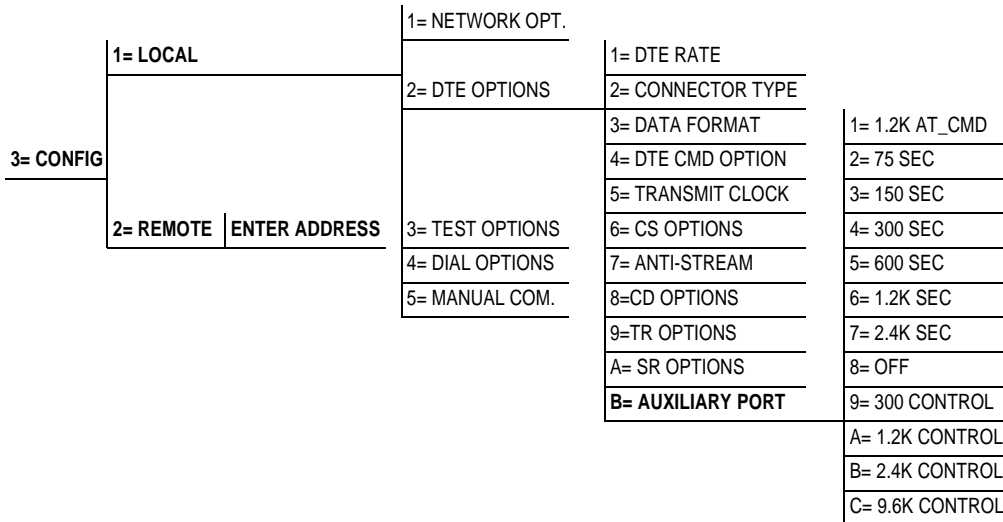

Figure 6-12. Setting the Secondary Rate

Table 6-11 shows the equivalent AT commands for setting the secondary rate option. Network throughput is shown in Table 6-12.

Table 6-11. Auxiliary Port AT Commands

Front Panel	AT Command	Description
1=OFF	_Y0	No secondary channel selected
2=75	_Y1	Secondary channel rate: 75 bps
3=150	_Y2	Secondary channel rate 150 bps
4=300	_Y3	Secondary channel rate: 300 bps
5=600	_Y4	Secondary channel rate 600 bps
6=1.2K	_Y5	Secondary channel rate 1200 bps
7=2.4K	_Y6	Secondary channel rate: 2400 bps

Table 6-12. DSU III AR Network Throughput

Loop Rate	Secondary Channel Throughput
2.4k	78
4.8k	156
9.6k	312
19.2k	627
38.4k	1.25k
56k No Scrambler	1.83k
56k Scrambler	2.4k

Chapter 7 Configuring Test Options

TEST OPTIONS

The **TEST OPTIONS** menu enables or disables different test modes and specifies the maximum test time allowed.

Test Time-out

The **TEST TIME-OUT** option sets the length of time a DSU III AR remains in a test mode before automatically returning to the data mode. Enter the time-out from 0 to 255 seconds. The factory default setting is off (0). Figure 7-1 shows the menu path used to access **TEST TIME-OUT**.

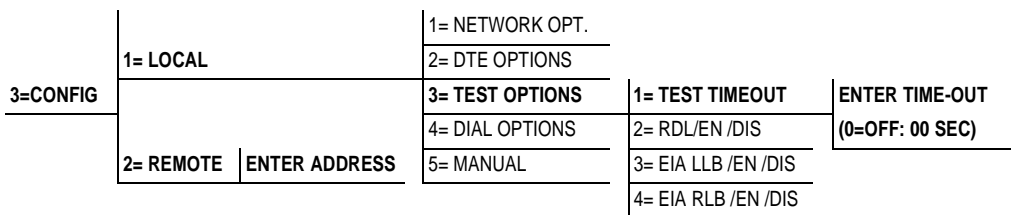

Figure 7-1. Setting Test Time-out Option

Table 7-1 shows the equivalent AT commands for setting the **TEST TIME-OUT**.

Table 7-1. Test Timeout AT Commands

Front Panel	AT Command	Description
ENTER TIMEOUT	S18=x	Specify 0 - 255 seconds test time-out

Remote Digital Loopback

The **REMOTE DIGITAL LOOPBACK (RDL)** option specifies whether the DSU III AR responds to an RDL request from the far end of the circuit. The factory default setting is **RDL ACCEPTED**. Figure 7-2 shows the menu path used to access this option.

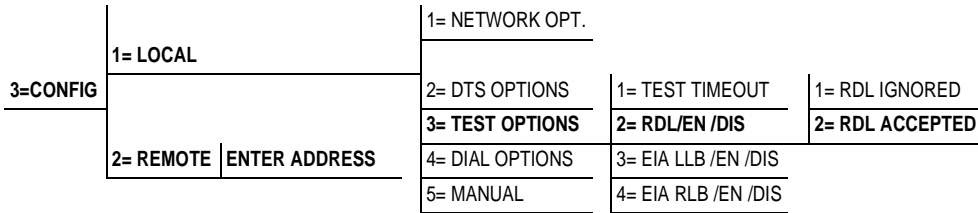

Figure 7-2. Remote Digital Loopback

Table 7-2 shows the equivalent AT commands for setting the **RDL OPTION**.

Table 7-2. Remote Digital Loopback AT Commands

Front Panel	AT Command	Description
1=RDL IGNORED	&T5	RDL request from remote DSU ignored
2=RDL ACCEPTED	&T4	RDL request accepted

EIA Local Loopback

The **EIA LLB** (Electronics Industries Association Local Loopback) option specifies whether the DSU III AR responds to the LLB input from the DTE. The factory default setting is **DISABLED**. Figure 7-3 shows the menu path used to access the **EIA LLB** option.

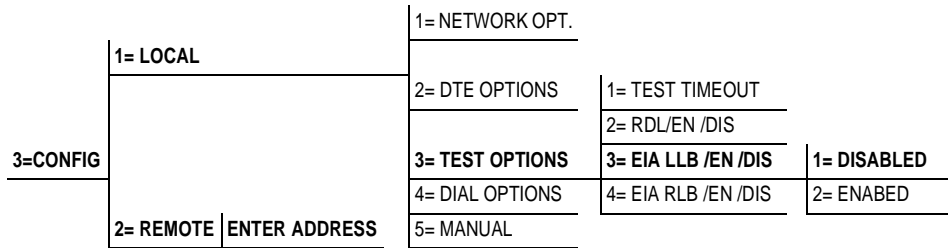

Figure 7-3. EIA Local Loopback Options

Table 7-3 shows the equivalent AT commands for setting the **EIA LLB** options.

Table 7-3. EIA Local Loopback AT Commands

Front Panel	AT Command	Description
1=DISABLED	_A0	EIA LLB disabled
2=ENABLED	_A1	EIA LLB enabled

EIA Remote Loopback

The **EIA RLB** (Electronics Industries Association Remote Loopback) option specifies whether the DSU III AR responds to the RLB input from the DTE. The factory default setting is **DISABLED**.

Figure 7-4 shows the menu path for the **EIA RLB** options.

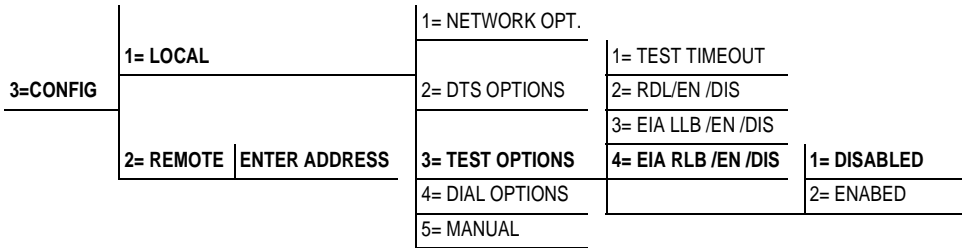

Figure 7-4. EIA Remote Loopback Options

Table 7-4 shows the equivalent AT commands for setting the **EIA RLB** options.

Table 7-4. EIA Remote Loopback AT Commands

Front Panel	AT Command	Description
1=DISABLED	_R0	EIA RLB disabled
2=ENABLED	_R1	EIA RLB enabled

Chapter 8 Configuring Dial Options

DIAL OPTIONS

The **DIAL OPTIONS** menu stores up to ten phone numbers and defines the **AUTO ANSWER** operation of the DSU III AR when it is configured for Switched 56 operation.

Phone Number

The DSU III AR stores up to 10 numbers of 36 digits each. Edit a phone number by reentering the entire number. This process overwrites the previously stored number. Figure 8-1 shows the menu path used to access the **PHONE NUMBER** option.

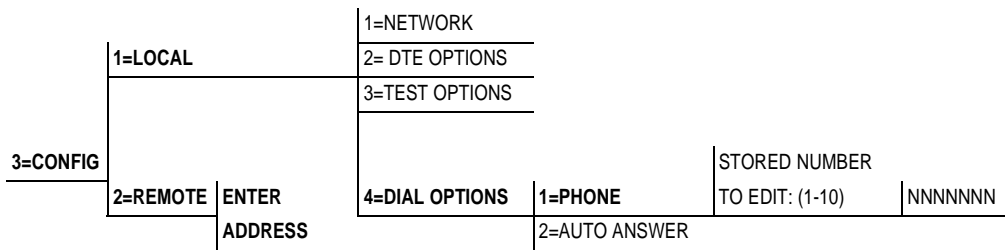

Figure 8-1. Editing Stored Phone Numbers

Table 8-1 shows the AT Command for storing phone numbers.

Table 8-1. AT Command for Storing Phone Numbers

AT Command	Description
&Zn=	Store Phone Number

Auto Answer

The **AUTO ANSWER** option is used to specify how incoming calls are to be answered. If **ENABLED**, incoming calls are automatically answered by the DSU III AR. If **DISABLED**, an incoming call can be answered manually by an AT or V.25 command from the DTE, or by raising TR from the DTE. Figure 8-2 shows the menu path used to enable or disable this option.

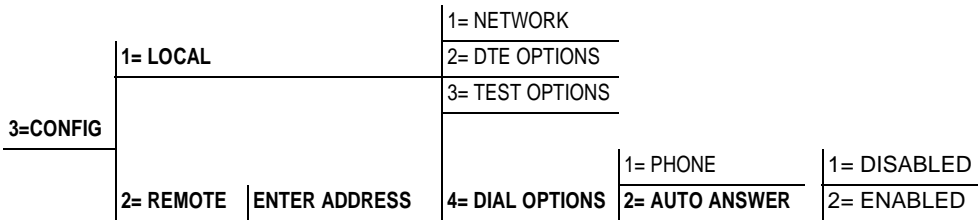

Figure 8-2. Enabling/Disabling the Auto Answer Function

Table 8-2 shows the AT Commands available for the **AUTO ANSWER** option.

Table 8-2. AT Commands for Auto Answer

Front Panel	AT Command	Description
1=DISABLED	_J0	Auto Answer disabled
2=ENABLED	_J1	Auto Answer enabled

Chapter 9 Manual Command

MANUAL COMMAND

The **MANUAL COMMAND** option is a shortcut method for entering configuration and control commands for the DSU III AR.

The first display prompts the user to enter the command number.

COMMAND : 00

Figure 9-1 shows the menu path for **MANUAL COMMAND**.

The available manual commands are listed in Table 9-1 on page 9-3.

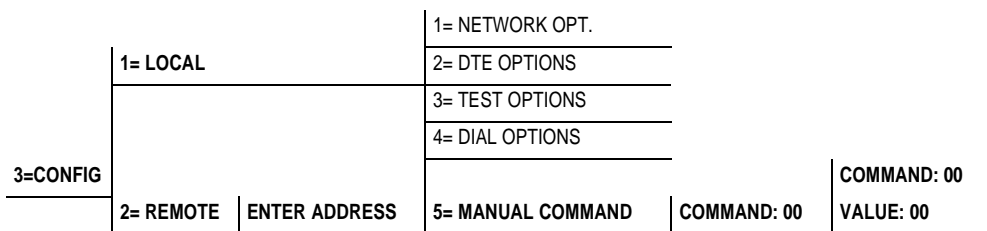

Figure 9-1. Menu Path for Manual Command

Using the Front Panel to Enter a Manual Command

When using the front panel, perform the following steps to enter a manual command.

Step	Action	Explanation
1	Use the number keys to enter the hexadecimal command number. Press Enter to complete.	When the command number is entered, the display shows both the command number and the present value or setting for the command.
2	The command value can be edited or reissued with the existing value. COMMAND: XX VALUE: 00	
3	Use the number keys to enter the hexadecimal value.	
4	Press Enter to complete.	The system briefly displays COMMAND ACCEPTED and returns to the active menu.

Table 9-1. Manual Commands

Command Description	Command	Value
AT Command Echo		
Disable	82	00
Enable	82	01
AT Result code		
Enable	85	00
Disable	85	01
AT Long or Short code		
Short form	86	00 to FF
Long form	86	00 to FF
AT Escape Character	2	00 to FF
AT CR Character	3	00 to FF
AT LF Character	4	00 to FF
AT BS Character	5	00 to FF
AT Escape Char. Timer	0C	00 to FF
Abort Call Timer	7	00 to FF
DTR Recognize Delay (x 2.5ms)	19	00 to FF
DTR Initiated Command Time-out (seconds)	28	00 to FF
Load Factory Opt.		
Option Set #1	8A	00
Option Set #2	8A	01
Option Set #3	8A	02
Option Set #4	8A	03
Store User Profile		
Save to Profile 0	91	00
Save to Profile 1	91	01
Select User Profile		
Power Up Profile 0	93	00
Power Up Profile 1	93	01
Network Address Lock		
Network Addr. Unlock	C3	00
Network Addr. Lock	C3	01

Chapter 10 Dial Selection

DIAL OPTIONS

The **DIAL** selection available in the **MAIN** menu (**DIAL**) includes options for manual dialing, redialing, and dialing stored numbers. The **DIAL** selection is available for use only if **AT&T/MCI SW56** or **US SPRINT SW56** is the selected **NETWORK TYPE**. See *Network Type* on page 5-5 in Chapter 5.

Figure 10-1 below shows the menu path used to access these options.

4=DIAL	1= DIAL STORED #	Select Stored Number 1-A
	2= ENTER DIAL #	NNNNNNN
	3= REDAIL LAST #	

Figure 10-1. Dial Options Menu

Dial Stored Number

This option allows a stored number to be dialed. The numbers are stored within the **CONFIG** selection.

Figure 10-2 below shows the **CONFIG** menu path used to access the dial options and store phone numbers.

See Chapter 8 *Configuring Dial Options* on page 8-1 for more information.

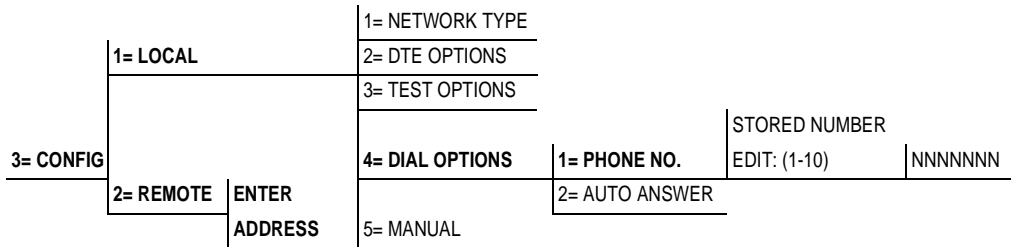

Figure 10-2. Path to Storing Numbers Option

Enter Dial Number

This option allows you to enter a phone number of up to 36 digits for the DSU III AR to dial.

Redial Last Number

Selecting this option redials the last phone number entered.

Chapter 11 Testing and Troubleshooting

TEST OVERVIEW

The DSU III AR performs a variety of diagnostic functions that isolate portions of the circuit to identify the problem source. Tests may be initiated and terminated from the front panel or the DTE interface. In asynchronous mode, AT commands can control the testing from the DTE interface. For synchronous operation, V.25 bis commands can provide test control.

The unit also responds to standard DDS network tests initiated from telco test centers. In addition, it can run several tests such as local and remote loopbacks to aid in problem isolation. See Figure 11-1.

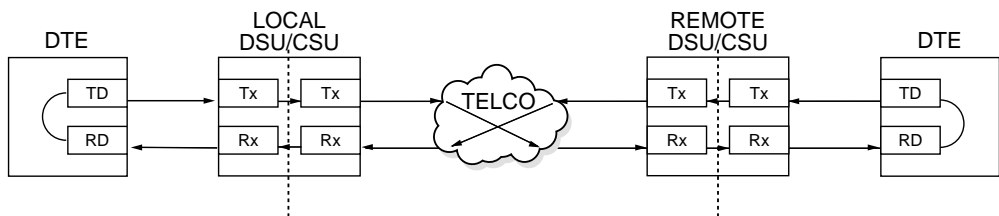

Figure 11-1. Normal Operation Before Initiating Loopback Test



All diagnostic tests disrupt data flow.

Initiating a Test

To initiate tests, perform the following steps:

Step	Action
1	To select TEST from the main menu, press 2; then press Enter .
2	Specify LOCAL , REMOTE , or AR testing by selecting the corresponding number; then press Enter .
3	Use the up and down arrows to view test options.
4	Select a test from the available options by pressing the corresponding number and then Enter .

The example in Figure 11-2 shows the menu path for initiating a local DTE and Loop test.

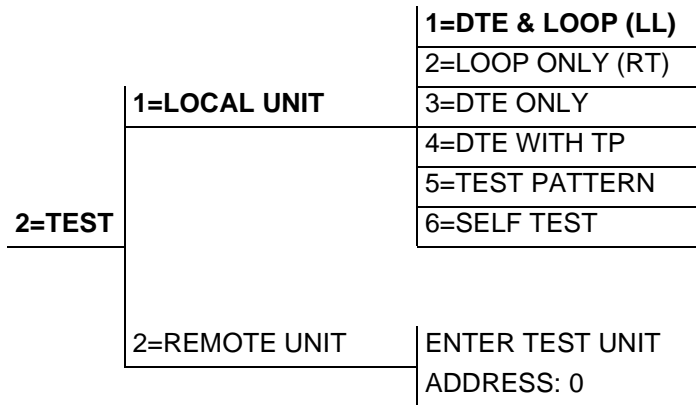

Figure 11-2. Initiating a Test

Once a test is initiated **PLEASE WAIT** displays briefly and is followed by the status screen.

Test Status Display

The **TEST STATUS** display appears automatically during a test. The **TEST STATUS** display is similar to the status screen described in Chapter 12, *Viewing Status Information* on page 12-1 with additional prompts for the type of test and the number of errors (for tests with a test pattern).

Figure 11-3 shows an example of a **TEST STATUS DISPLAY** for a DTE test with a test pattern. Figure 11-4 on page 11-4 shows the complete test menu.

DTE WITH TEST PATTERN TST ERR = 00	<p>While this menu is on the display: Press 1 to clear errors. Press 2 to inject an error.</p> <p>Use the up and down arrows to display other status screens.</p>
LOOP 56K DTE 56K SYNC	
TR SR LLB RLB OFF OFF OFF OFF	
UNIT IN TEST LOOP IS NORMAL	

Figure 11-3. Sample Test Status Displays

Exiting a Test

During a test, press the **Quick** key to access the **EXIT TEST/DISPLAY STATUS** menu or press **Cancel** to return to the Main menu. The **EXIT TEST/DISPLAY STATUS** menu provides the following options, which are available only after a test has been initiated:

- Exit Test** Exits the current test and returns to the Main menu.
- Display Status** Reenters test display.

TEST	1=LOCAL UNIT	1=DTE & LOOP (LL)	STATUS DISPLAY	1=EXIT TEST	
				2=DISPLAY STATUS	
		2=LOOP ONLY (RT)	STATUS DISPLAY	1=EXIT TEST	
				2=DISPLAY STATUS	
		3=DTE ONLY	STATUS DISPLAY	1=EXIT TEST	
				2=DISPLAY STATUS	
	2=REMOTE UNIT	4=DTE WITH TP	1=2047 PATTERN		
			2=511 PATTERN		1=EXIT TEST
			3=STRESS PTRN #1	STATUS DISPLAY	2=DISPLAY STATUS
			4=STRESS PTRN #2		
			5=STRESS PTRN #3		
			6=STRESS PTRN #4		
5=TEST PATTERN		1=2047 PATTERN			
		2=511 PATTERN			
		3=STRESS PTRN #1			1=EXIT TEST
		4=STRESS PTRN #2	STATUS DISPLAY	2=DISPLAY STATUS	
		5=STRESS PTRN #3			
		6=STRESS PTRN #4			
6=SELF TEST	STATUS DISPLAY				
ENTER TEST UNIT ADDRESS: 0	1=2047 PATTERN			1=EXIT TEST	
	2=511 PATTERN	STATUS DISPLAY	2=DISPLAY STATUS		
	3=STRESS PTRN #1				
	4=STRESS PTRN #2				
	5=STRESS PTRN #3				
	6=STRESS PTRN #4				
	7=DATA FROM DTE				

Figure 11-4. Complete Test Menu

When the **STATUS DISPLAY** is active, press the **Quick** key to access the **EXIT TEST** menus.

TROUBLESHOOTING

This section is intended to provide a quick and easy means of diagnosing suspected problems associated with local or remotely attached ADTRAN DSU/CSUs. Two separate troubleshooting sections are provided; one focuses on new installs, the other on existing circuits.

Messages from the DSU/CSU

The DSU III AR displays messages on the LCD display and LEDs concerning the status of the unit and the local loop. If the Alarm LED is **ON**, at least one of the messages shown in Table 11-1 will be displayed on the LCD.



NOTE

*The **STATUS** menu must be selected in order for the unit to display status messages. Press the **Quick** key to return to the main menu, where **STATUS** can be selected.*

Table 11-1. Messages from the DSU/CSU

Message	Meaning	Probable Cause	Action
LOOP IS NORMAL	Good local loop signal being received from the telco.	Indicates good local loop.	No action required; unit properly connected to telco circuit.
OPEN LOOP	Unit not receiving a signal from the telco.	Bad telco cable from the DSU to telco jack or bad circuit to telco.	Replace telco cable from DSU to wall jack. If a problem persists, contact telco provider.
NO RX SIGNAL	Unit detects sealing current but no data signal from telco.	Bad conductor in telco cable from DSU to telco jack or bad circuit to telco.	Replace telco cable from DSU to wall jack. If a problem persists, contact telco provider.
OOS/OOF FROM NET	Unit detects an Out of Service or Out of Frame condition from the telco.	Telco is having problems with DDS circuit or remote unit is turned off or disconnected.	Check remote unit. Contact telco service provider. If a problem persists, contact telco provider.

Table 11-1. Messages from the DSU/CSU (Continued)

Message	Meaning	Probable Cause	Action
CHECK TELCO LINE	Transmit/receive pair reversal detected.	Telco wall jack wired incorrectly.	Switch wire pairs in wall jack or contact telco service provider.
TEST FROM TELCO	Telco activated a loopback to test the DDS circuit.	Telco is testing circuit.	Wait until test is complete or contact telco service provider.

Troubleshooting New Installs

Before initiating diagnostics on a newly installed unit and/or DDS circuit and before contacting ADTRAN Technical Support, please check the items in Table 11-2 to ensure the unit is configured properly.

After verifying the items listed in Table 11-2 on page 11-7, the unit should operate properly and display the following:

DATA MODE
LOOP IS NORMAL

If a status message other than **DATA MODE LOOP IS NORMAL** is shown, begin performing diagnostics described in the section *Test Sequence for Troubleshooting New Installs or Existing Circuits* on page 11-8.

Table 11-2. Troubleshooting New Installs

Configuration Item to Check	Option Selection	Action
DTE Type	EIA-232 or V.35	Select the type of DTE interface option to connect to the DSU/CSU from the configuration menu.
Loop Rate	Auto, 2.4 to 64 kbps	Select the DDS loop rate of the DDS circuit from the configuration menu.
Data Format	Async or Sync	Select the type of data to be used from the configuration menu.
DTE Cable	N/A	Verify DTE cable connection to the proper DTE connector on the DSU/CSU.
Telco Cable	N/A	Verify the telco cable is securely connected to the DSU/CSU and wall jack.
Power the unit Off and then On.	N/A	Verify the unit passes self test during power-up (displayed on the LCD).

Test Sequence for Troubleshooting New Installs or Existing Circuits

If your DSU...	Do this...
seems to be having problems	Perform a Self Test to determine if the unit is operational
is receiving excessive data errors	Perform a DTE with Test Pattern requiring retransmission to determine if the unit's internal transmitter and receiver is operating error free
is receiving excessive errors requiring retransmission of data and the remote unit is error free	Perform a Remote Test to verify the connection between the local and remote unit is error free. Run the test using all available test patterns



If an external BERT tester is available, these additional tests may be performed: DTE & Loop Test, DTE Only Test, and Loop Only Test.

If the unit fails any of these tests or the problem has not been determined, contact ADTRAN Technical Support (see page xi in the front section of this manual).

The DSU III AR unit diagnostics tests can be initiated through AT Commands from the DTE interface. These commands are listed in Table 11-3 on page 11-9.

Table 11-3. AT Commands

Command	Title	Default
A/	Re-execute Command	none
ATA	Answer	none
ATDn	Dial Number	none
ATE	Echo Command	1
ATH	Hang Up Call	none
ATO	Go Online	none
ATQn	Result Code Display	0
ATSn?	Read S-Register	none
ATSn=x	Write to S-Register	none
ATVn	Result Code From	1
ATZ	Reset	none
AT&Cn	DCD Option	0
AT&Dn	DTR Option	0
AT&Fn	Restore Factory Options	none
AT&Kn	Flow Control	none
AT&Ln	Network Type	0
AT&Qn	DTE Data Format	0
AT&Rn	CS Options	0
AT&Sn	SR Options	0
AT&Tn	Test Commands	0
AT&V	View Current Configuration	none
AT&Wn	Store User Profile	0

LOCAL UNIT DIAGNOSTICS

The local DSU III AR can perform six different tests. These tests can be initiated through AT Commands from the DTE Interface. See Table 11-4 for a list of the AT Commands.

Table 11-4. Test AT Commands

Front Panel Display	AT Command	Description
DTE & Loop (LL)	&T10	TD/RD and RX/TX Loopbacks
Loop Only (RT)	&T11	RX/TX Loopback at Network Interface
DTE Only	&T1	TX/RX Loopback at DTE Interface
DTE with TP	&T8	RX/RX Loopback with Test Pattern
Test Pattern	&T9	Transmit/Receive Test Pattern
Self Test	Z	Check Internal Components (Resets Unit)
Exit Test	&T0	Stops test, returns to data mode
TD = Customer Transmit Data RD = Customer Receive Data TX = Network Transmit Data RX = Network Receive Data		

The test patterns shown in Table 11-5 on page 11-11 are available for the DTE with Test Pattern and Test Pattern tests.

Table 11-5. DTE With Test Pattern Commands

Front Panel	AT Command	Description
1=2047 PATTERN	_T0&T8	Standard 2047 random data pattern.
2=511 PATTERN	_T1&T8	Standard 511 random data pattern.
3=STRESS PTRN #1	_T2&T8	Stress pattern with alternating high and low ones densities. Repeated pattern of 100 octets: 1111 1111; followed by 100 octets: 0000 0000.
4=STRESS PTRN #2	_T3&T8	Stress pattern with alternating medium and low ones densities. Repeated pattern of 100 octets: 0111 1110; followed by 100 octets: 0000 0000.
5=STRESS PTRN #3	_T4&T8	Stress pattern with medium ones density. Continuous series of octets: 0011 0010.
6=STRESS PTRN #4	_T5&T8	Stress pattern with low ones density. Continuous series of octets: 0100 0000.

DTE and Loop (LL)

Test Description

The **DTE & LOOP** test splits the DSU III AR into two separate DTE and loop interface sections and then loops the receive data of each interface back to its respective transmit data. The **DTE & LOOP** test provides a bidirectional loopback at the DSU/CSU.

Figure 11-5 illustrates the loopback points and the signal paths for this test.

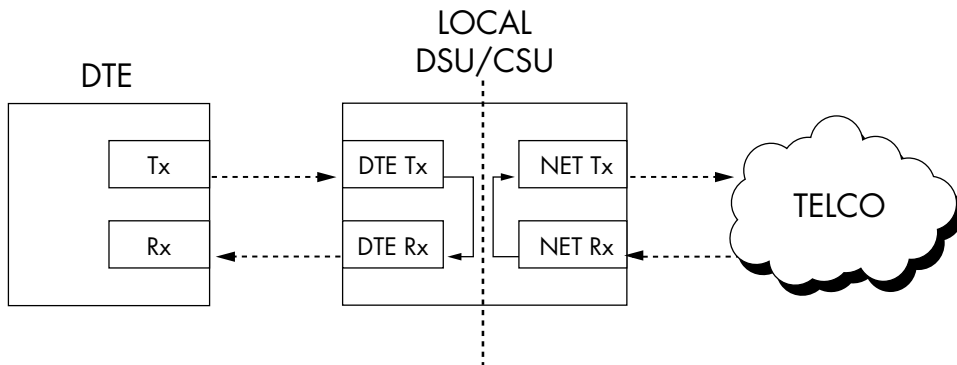

Figure 11-5. DTE & Loop Test

Test Purpose

The DTE & Loop test is used for the following purposes:

- Verify integrity of the DTE interface and cable.
- Provide a loopback for network tests.

Initiating

Follow the menu path outlined in Figure 11-6 to initiate a **DTE & LOOP TEST**.

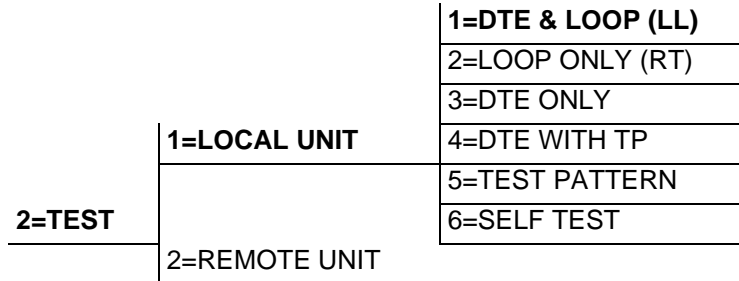

Figure 11-6. Initiating a DTE & Loop Test

Interpreting Test Results

A BERT tester must be used to interpret the test results of a DTE & Loop test because the BERT originates external to the local DSU.

Loop Only (RT)

The **LOOP ONLY (RT)** test allows the loop interface and a major portion of the DTE interface for the local DSU III AR to be tested from the remote site over the actual communication circuit.

Figure 11-7 illustrates the loopback point and the signal paths for this test.

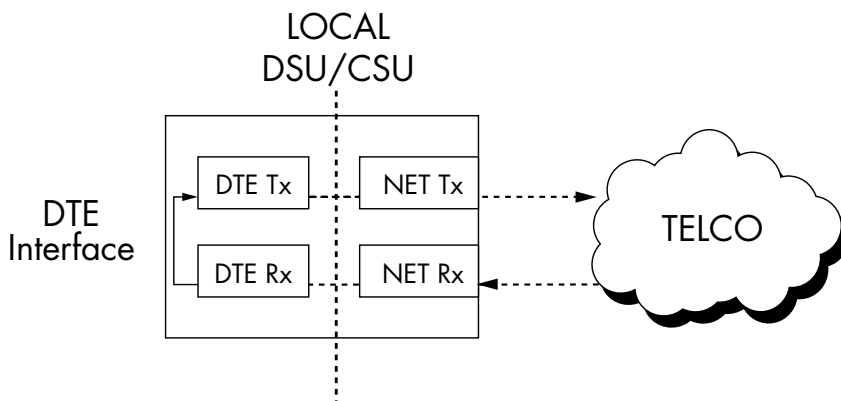

Figure 11-7. Loop Only Test

Test Purpose

The **LOOP ONLY** test is used to provide a loopback for network tests.

Initiating

Follow the menu path outlined in Figure 11-8 to initiate a **LOOP ONLY** test.

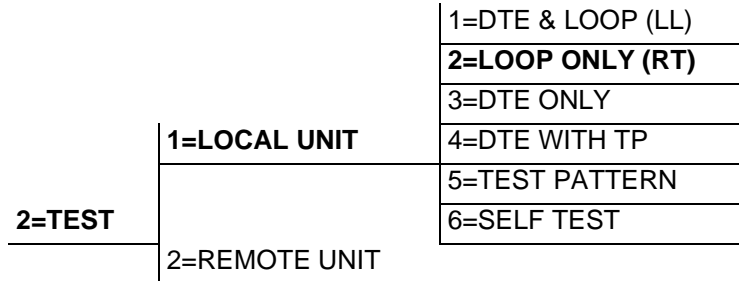

Figure 11-8. Initiating a Loop Only Test

Interpreting Test Results

The **LOOP ONLY** test is used for looping the DDS circuit back to the telco. No test results are available from the local DSU III AR.

DTE Only

The **DTE ONLY** test provides a method for testing both the DTE interface drivers and receivers of the local DSU III AR plus its loop transmitter and receiver. For this test, the loop transmit data is connected to the loop receive data at a point close to the physical network interface. This test can be used to verify proper operation between the local DTE and the local DSU III AR. See Figure 11-9.

NOTE *When this test is implemented, the far unit receives an **OOS/OOF** message from the network and enters an alarm state.*

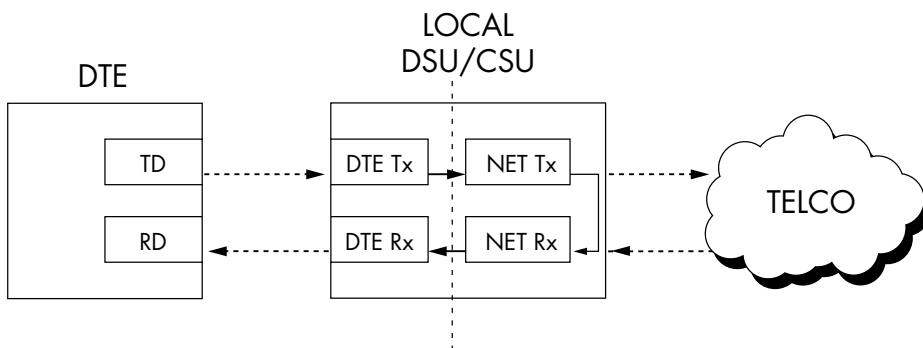

Figure 11-9. DTE Only Test Diagram

Test Purpose

The **DTE ONLY** test is used for the following purposes:

- To verify the integrity of the DTE interface.
- To verify the integrity of connection between DTE and DSU III AR.

Initiating

Follow the menu path outlined in Figure 11-10 to initiate a **DTE ONLY** test.

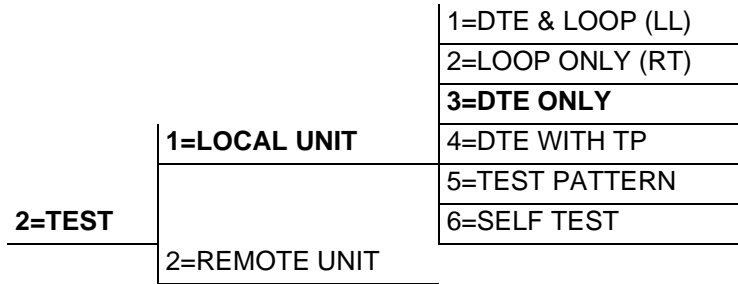

Figure 11-10. Initiating a DTE Only Test

Interpreting Test Results

A BERT tester must be used to interpret the test results of a **DTE ONLY** test because the BERT originates external to the local DSU.

DTE With Test Pattern

The DTE with TP (test pattern) test is similar to the **DTE ONLY** test described previously except the test pattern is generated in the DSU using the DSU/CSU internal test pattern generator. This test can be used to detect deficiencies within the internal drivers and receivers of the DSU III AR. Figure 11-11 illustrates the loopback point and the data paths for this test.

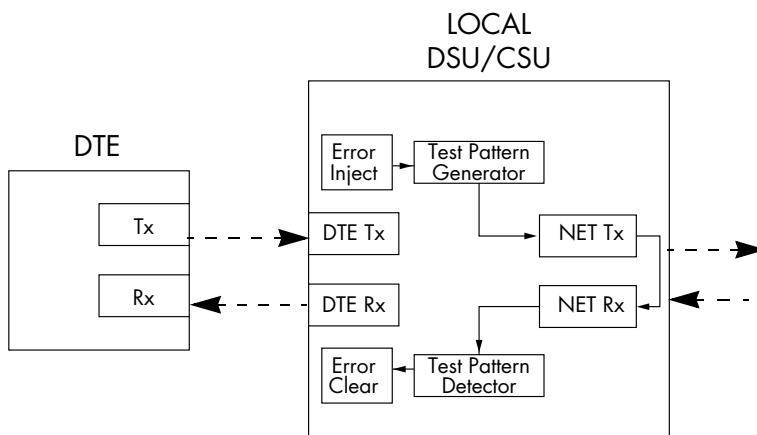

Figure 11-11. DTE with Test Pattern

Test Purpose

A DTE test using a test pattern is used for the following purposes:

- Verify integrity of the DTE interface.
- Verify integrity of connection between DTE and DSU III AR.

Initiating

Follow the menu path outlined in Figure 11-12 to initiate a DTE Test using a 511 Test Pattern.

		1= DTE & LOOP (LL)	1= 2047 PATTERN
		2= LOOP ONLY (RT)	2= 511 PATTERN
		3= DTE ONLY	3= STRESS PTRN #1
	1=LOCAL UNIT	4= DTE WITH TP	4= STRESS PTRN #2
		5= TEST PATTERN	5= STRESS PTRN #3
		6= SELF TEST	6= STRESS PTRN #4
2=TEST			
	2=REMOTE UNIT		

Figure 11-12. Initiating a DTE Test with Test Pattern

Interpreting Test Results

If the unit is functioning properly, the DSU III AR displays:

```
DTE WITH TP
TST ERR=0000
```

The first line of the display indicates the type of test being performed, while the second line of the display indicates the number of errors accumulated by the test pattern detector.

If errors occur during this test, the test error count can be reset to zero by pressing **1** on the keypad.

To verify proper operation of this test, single bit errors can be injected into the transmitted test pattern by pressing **2**. These errors appear on the **TEST ERR** display.

Keypad	Effect
1	Zeros error counter
2	Injects single Error

Test Pattern

The **TEST PATTERN** option converts the local DSU III AR into a BERT tester for the purpose of testing the DDS circuit. When this test is used, the remote DSU/CSU must be in loopback or transmitting a test pattern. Figure 11-13 illustrates the data paths for this mode.

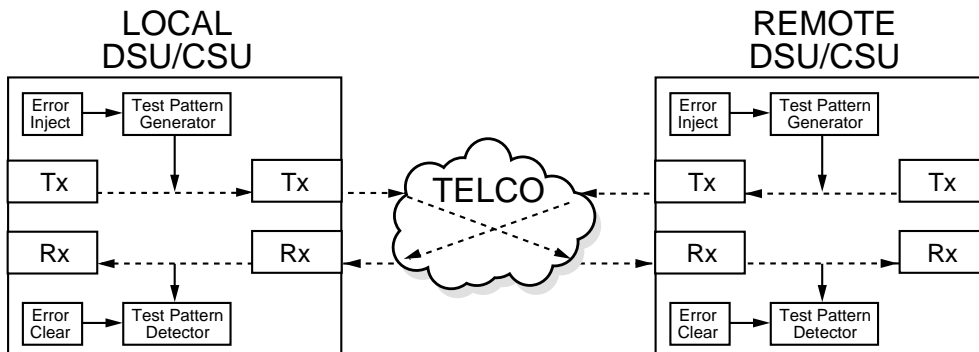

Figure 11-13. Test Pattern Only

Test Purpose

Testing by using a test pattern is used for the following purposes:

- Transmits user selected test pattern using an internal test pattern generator, and compares the received data using internal test pattern detector to detect whether there are any errors on the DDS circuit
- Injects errors and verifies the unit transmits data across the communication circuit to the remote unit.
- Helps determine from which direction the circuit is receiving errors.

Initiating

Follow the menu path outlined in Figure 11-14 to initiate a test using a 511 test pattern.

		1= DTE & LOOP (LL)	1= 2047 PATTERN
		2= LOOP ONLY (RT)	2= 511 PATTERN
		3= DTE ONLY	3= STRESS PTRN #1
	1= LOCAL UNIT	4= DTE WITH TP	4= STRESS PTRN #2
		5= TEST PATTERN	5= STRESS PTRN #3
		6= SELF TEST	6= STRESS PTRN #4
2=TEST	2= REMOTE UNIT		

Figure 11-14. Initiating a Test Using a Test Pattern

Interpreting Test Results

If the unit is functioning properly, the display should show the following:

```
TEST PATTERN
TST ERR = 0000
```

The first line of the display indicates the type of test being performed while the second line of the display indicates the number of errors accumulated by the test pattern detector.

If errors occur during this test, the test error count can be reset to zero by pressing **1** on the keypad.

To verify proper operation of this test, single bit errors can be injected into the transmitted test pattern by pressing **2**. These errors appear on the **TEST ERR** display.

Keypad	Effect
1	Zeros error counter
2	Injects single Error

Self Test

The **SELF TEST** verifies current operation of the DSU III AR. It can be performed at any time and is recommended if there is any question about the DSU's health.

Test Purpose

To determine if the DSU is functioning properly.

Initiating

Follow the menu path outlined in Figure 11-15 to initiate a test using a test pattern.

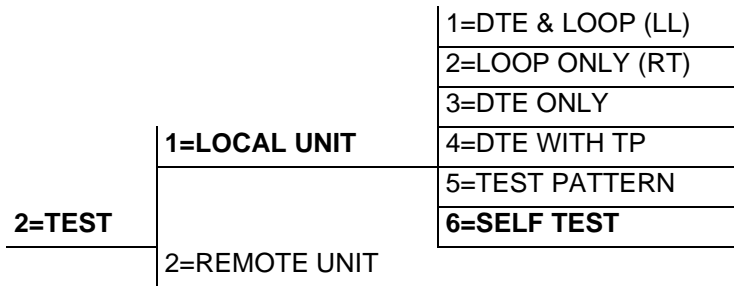

Figure 11-15. Initiating a Self Test

Interpreting Test Results

Once **SELF TEST** is activated, the LEDs cycle on and off as the system runs the self test. A pass or fail status will be displayed on the LCD along with a checksum indicating the current firmware revision.

REMOTE UNIT DIAGNOSTICS

A remote DSU III AR can perform seven different tests; see Table 11-6.

Table 11-6. Remote Tests and AT Commands

Front Panel	AT Command	Description
1=2047 PATTERN	_T0&T7	Standard 2047 random data pattern
2=511 PATTERN	_T1&T7	Standard 511 random data pattern
3=STRESS PTRN #1	_T2&T7	DDS Stress Pattern #1
4=STRESS PTRN #2	_T3&T7	DDS Stress Pattern #2
5=STRESS PTRN #3	_T4&T7	DDS Stress Pattern #3
6=STRESS PTRN #4	_T5&T7	DDS Stress Pattern #4
7=DATA FROM DTE	&T6	Data from DTE

The **REMOTE UNIT** submenu allows a remotely installed DSU to be placed into loopback. There are six test patterns to choose from or **DATA FROM THE DTE** may be selected. See Figure 11-16.

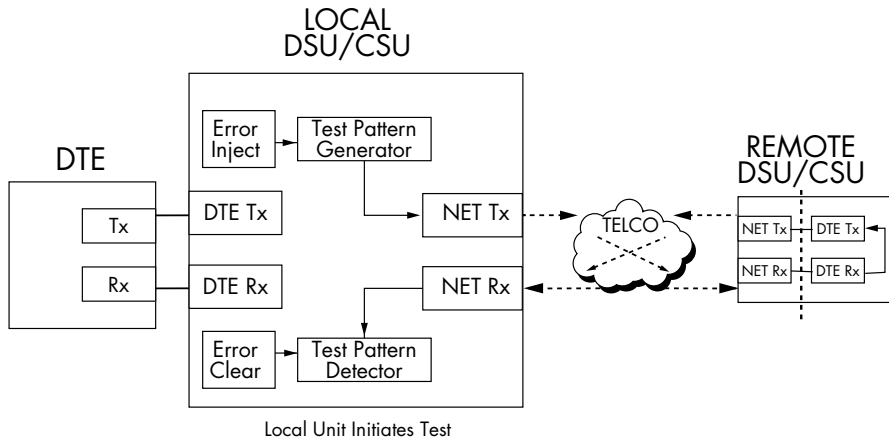

Figure 11-16. V.54 RDL with Test Pattern

Test Purpose

Test the local DSU, the DDS circuit, and remote DSU.

Initiating

Follow the menu path outlined in Figure 11-17 to place a remote DSU III AR into loopback.

			1= 2047 PATTERN
			2= 511 PATTERN
			3= STRESS PTRN #1
			4= STRESS PTRN #2
			5= STRESS PTRN #3
			6= STRESS PTRN #4
			7= DATA FROM DTE
	1= LOCAL UNIT		
2= TEST		ENTER TEST UNIT	
	2= REMOTE UNIT	ADDRESS: 0	

Figure 11-17. Initiating a Remote Test

After selecting **REMOTE UNIT** from the menu, the following prompt is displayed for entering the address for the remote unit:

```
Enter Test Unit
Address:0
```

Use the number keys to type the address of the remote DSU; then press **Enter**. The test pattern selections are displayed. After a test pattern is selected, the system briefly displays **PLEASE WAIT**.

Test Results

If the test is successful the status menu is displayed. If not, **UNABLE TO EXECUTE TEST** is displayed.

Interpreting Test Results

If the unit is functioning properly, the display should show:

TST ERR = 0000

The keypad buttons can be used to manually inject errors and clear the error count.

Keypad	Effect
1	Zeros error counter
2	Injects single Error

Chapter 12 Viewing Status Information

STATUS DISPLAY

The **STATUS** selection displays two lines at a time of the current operational status of the network and the DTE interfaces.

After 30 seconds of no front panel operation, the DSU III AR automatically reverts to the status display. Examples of possible status displays are shown in Figure 12-1.

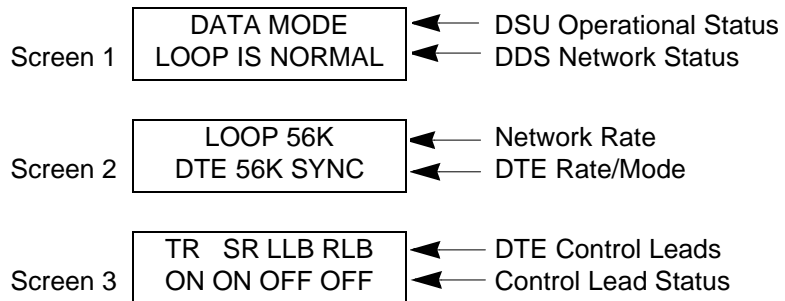

Figure 12-1. Examples of Status Displays

DSU Operational Status

Possible messages include:

Message	Description
DATA MODE	The unit is ready to pass data if network status is normal.
UNIT IN TEST	The unit is in test. Scroll to next status menu for test type.
DTE COMMAND MODE	The unit is in command mode from the DTE (AT or V.25 bis).
In SW56 mode the following messages are possible:	
IDLE	The unit is idle, waiting for a call or a dial command.
INCOMING CALL	The unit has detected an incoming call.
DIALING	The unit is dialing a number.

DDS Network Status

This line of the display shows the current status of the dedicated network interface. Possible messages include:

Message	Description
LOOP IS NORMAL	The DSU III is connected to the dedicated line. No line irregularity detected.
OPEN LOOP	The DDS physical connection has been broken.
NO RX SIGNAL	The DSU III detects sealing current but no receive signal.
CHECK TELCO LINE	The DSU III detects a possible reversal in the Rx and Tx pairs.
OOS/OOF FROM NET	The DSU III detects an abnormal condition code from the network.
NO FRAME SYNC	The DSU III cannot sync on the signal from the telco (64k or secondary channel mode only).
TEST FROM TELCO	The DSU III is in a test initiated from the telco. Scroll to next status menu for test type.
RATE ADAPTING	The DSU III is attempting to determine the loop rate provided from the telco.
In SW56 mode the following messages are possible:	
ANSWERING CALL	The DSU III is answering an incoming call.
NO WINK FROM CO	The DSU III did not see a proper signal from the network during dialing.
CALL DISCONNECT	The SW56 was terminated.

Network Rate

The message displayed on this line of the **STATUS** display screen indicates the rate of the service configured for the network.

DTE Rate/Mode

The message displayed on this line of the **STATUS** display screen indicates the DTE data rate and format.

DTE Control Leads and Status

Four additional DTE interface leads are displayed with their current status (on or off) displayed below them. The leads are identified as follows:

- TR - Data terminal ready
- SR - Data set ready
- LLB - Local loopback
- RLB - Remote loopback

Appendix A Pinouts

Table A-1. RJ-48S Telco Connector Pinouts

Pin	Name	Description
1	R1	Transmit Data from DSU to Network-Ring 1
2	T1	Transmit Data from DSU to Network-Tip 1
3-6	-	Not Used
7	T	Receive Data from Network to DSU-Tip
8	R	Receive Data from Network to DSU-Ring

Table A-2. Primary EIA-232 Connector Pinouts

Pin	EIA	Description
1	AA	Protective Ground (PG)
2	BA	Transmit Data (TD)
3	BB	Receive Data (RD)
4	CA	Request to Send (RS)
5	CB	Clear to Send (CS)
6	CC	Data Set Ready (SR)
7	AB	Signal Ground (SG)
8	CF	Received Line Signal Detector (CD)
9	-	+12 Test Point
10	-	-12 Test Point
15	DB	Transmit Clock (TC)
17	DD	Receive Clock (RC)
18	-	Local Loopback (LL)
20	CD	Data Terminal Ready (TR)
21	-	Remote Loopback (RL)
22	CE	Ring Indicator (RI)
24	DA	External TX Clock (ETC)
25	-	Test Indicator (TI)

Table A-3. Primary V.35 Connector Pinouts

Pin	CCITT	Description
AA	101	Protective Ground (PG)
B	102	Signal Ground (SG)
C	105	Request to Send (RTS)
D	106	Clear to Send (CTS)
E	107	Data Set Ready
F	109	Received Line Signal Detector (CD)
H	-	Data Terminal Ready (DTR)
J	-	Ring Indicator
L	-	Local Loopback (LL)
N	-	Remote Loopback (RL)
R	104	Received Data (RD-A)
T	104	Received Data (RD-B)
V	115	Receiver Signal Element Timing (SCR-A)
X	115	Receiver Signal Element Timing (SCR-B)
P	103	Transmitted Data (SD-A)
S	103	Transmitted Data (SD-B)
Y	114	Transmitter Signal Element Timing (SCT-A)
AA	114	Transmitter Signal Element Timing (SCT-B)
U	113	External TX Signal Element (SCX-A)
W	113	External TX Signal Element (SCX-B)
NN	-	Test Indicator (TI)

Table A-4. Auxiliary EIA-232 Connector Pinouts

Pin	CCITT	Description
1	AA	Protective Ground (PG)
2	BA	Transmit Data (TD)
3	BB	Receive Data (RD)
4	CA	Request to Send (RS)
5	CB	Clear to Send (CS)
6	CC	Data Set Ready (SR) On all the time.
7	AB	Signal Ground (SG)
8	CF	Received Line Signal Detector (CD) On all the time.

Appendix B AT Commands

This Appendix lists all the AT Commands available for the DSU III AR.

Table B-1. AT Commands

Command	Title	Default
A/	Re-execute Command	none
ATA	Answer	none
ATDn	Dial Number	none
ATE	Echo Command	1
ATH	Hang Up Call	none
ATO	Go Online	none
ATQn	Result Code Display	0
ATSn?	Read S-Register	none
ATSn=x	Write to S-Register	none
ATVn	Result Code From	1
ATZ	Reset	none
AT&Cn	DCD Option	0
AT&Dn	DTR Option	0
AT&Fn	Restore Factory Options	none
AT&Kn	Flow Control	none
AT&Ln	Network Type	0
AT&Qn	DTE Data Format	0
AT&Rn	CS Options	0
AT&Sn	SR Options	0
AT&Tn	Test Commands	0
AT&V	View Current Configuration	none
AT&Wn	Store User Profile	0

Table B-2. Loop Rate Commands

Front Panel	AT Command
AUTO	%B0
2.4K with no secondary channel	%B1
4.8K with no secondary channel	%B2
9.6K with no secondary channel	%B3
19.2K with no secondary channel	%B4
38.4K with no secondary channel	%B5
56K with no secondary channel	%B6
64K clear channel	%B7
2.4K with secondary channel	%B9
4.8K with secondary channel	%B10
9.6K with secondary channel	%B11
19.2K with secondary channel	%B12
38.4K with secondary channel	%B13
56K with secondary channel	%B14

Table B-3. Network Address Command

Front Panel	AT Command	Description
XX (Decimal)	_N=xx	Assigns a 2 digit Network Address

Table B-4. Remote Configuration Commands

Front Panel	AT Command	Description
1=DISABLE	&P4	Disable Remote Configuration
2=ENABLE	&P5	Enable Remote Configuration

Table B-5. Network Type Commands

Front Panel	AT Command	Description
1=DEDICATED	&L0	Any 4-wire DDS Network
2=AT&T/MCI	&L1	AT&T/MCI Switched 56 Service
3=US SPRINT	&L2	US SPRINT Switched 56 Service

Table B-6. Clock Source Commands

Front Panel	AT Command	Description
1=MASTER	_X0	DSU is the master timing source
2=FROM NETWORK	_X1	Network RX Signal is timing source

Table B-7. DTE Rate AT Commands

Front Panel	AT Command	Description
1=DTE 2.4K	%K3	DTE rate 2.4K sync and async
2=DTE 4.8K	%K4	DTE rate 4.8K sync and async
3=DTE 9.6K	%K5	DTE rate 9.6K sync and async
4=DTE 19.2K	%K6	DTE rate 19.2K sync and async
5=DTE 38.4K	%K7	DTE rate 38.4K sync and async
6=DTE 56K/57.6K	%K8	DTE rate 56K sync or 57.6K async
7=SAME AS LOOP	%K9	DTE rate same as loop speed

Table B-8. Scrambler On/Off AT Commands

Front Panel	AT Command	Description
1=SCRAMBLER OFF	_F0	DTE data scrambler disabled
2=SCRAMBLER ON	_F1	DTE data scrambler enabled
3=DATA INVERT	_F2	DTE data invert enabled (56 kbps secondary channel Loop Rate only). LBE codes from DTE suppressed (64 kbps only).

Table B-9. Data Format Commands

Front Panel	AT Command	Description
1=ASYNCHRONOUS	&Q0	Always asynchronous
2=SYNCHRONOUS	&Q2	Always synchronous
For asynchronous options, select the length of the data bytes.		
1=ASYNC 9 BITS	N/A	9 bits including start, stop, parity
2=ASYNC 10 BITS	N/A	10 bits including start, stop, parity
3=ASYNC 11 BITS	N/A	11 bits including start, stop, parity

Table B-10. Transmit Clock AT Commands

Front Panel	AT Command	Description
1=NORMAL	&X0	TX clock from DSU selected
2=EXTERNAL	&X1	ETC clock from DTE selected

Table B-11. CS Options AT Commands

Front Panel	AT Command	Description
1=FORCED ON	&R0	CS always on.
2=FOLLOWS RS	&R1	CS on with RS after delay; off when RS or if DSU cannot pass data.
3=FOLLOWS CD	&R2	CS off when CD goes off or if DSU cannot pass data.
4=FOLLOWS RS+CD	&R3	CS follows RS after delay and also off if CD off. If CD goes off after RS is on, DSU III AR will turn off CS but continue to pass data until RS goes off. CS also off if DSU cannot pass data.
5=OFF WITH LOCD	&R4	Off 5 sec after LOCD. Valid only in SW56 mode. CS is forced on but will turn off for 5 seconds after a call is disconnected.
For RS options, select the RS to CS delay length.		
1=CS DELAY SHORT	_D0	Short Delay from RS to CS selected.
2=CS DELAY LONG	_D1	Long Delay from RS to CS selected.

Table B-12. Anti-Stream AT Commands

Front Panel	AT Command	Description
1=TIMER OFF	%T0	Anti-stream timer disabled
2=TIME 10 SEC.	%T1	Time-out equal 10 seconds
3=TIME 30 SEC.	%T2	Time-out equal 30 seconds
4=TIME 60 SEC.	%T3	Time-out equal 60 seconds

Table B-13. CD Options AT Commands

Front Panel	AT Command	Description
1=FORCED ON	&C0	On all the time.
2=NORMAL	&C1	On only when data present on loop.
3=OFF WITH LOCD	&C2	On except after disconnect in Switched 56 application.

Table B-14. TR Options AT Commands

Front Panel	AT Command	Description
1=IGNORE	&D0	Ignore the TR input.
2=IDLE WHEN OFF	&D2	See the following Note.
3=OFF>ON DIAL #1	&D3	Dial Stored #1: TR goes off to on (SW56 only).
4=OFF>ON DIAL #2	&D4	Dial Stored #2: TR goes off to on (SW56 only).

Table B-15. SR Options AT Commands

Front Panel	AT Command	Description
1=FORCED ON	&S0	Always on.
2=OFF OOS ONLY	&S1	Off when network Out Of Service (OOS).
3=OFF LOCD ONLY	&S3	Off 5 seconds after disconnect (SW56 only).
4=OFF TEST ONLY	&S0_C0	Off when unit is in test.
5=OFF TEST +OOS	&S1_C0	Off in test or OOS.
6=OFF TEST +LOCD	&S5	Off 5 seconds after disconnect or test.

Table B-16. Secondary Rate AT Commands

Front Panel	AT Command	Description
1=OFF	_Y0	No secondary channel selected
2=75	_Y1	Secondary channel rate: 75 bps
3=150	_Y2	Secondary channel rate 150 bps
4=300	_Y3	Secondary channel rate: 300 bps
5=600	_Y4	Secondary channel rate 600 bps
6=1.2K	_Y5	Secondary channel rate 1200 bps
7=2.4K	_Y6	Secondary channel rate: 2400 bps

Table B-17. Test Time-out AT Commands

Front Panel	AT Command	Description
ENTER TIMEOUT	S18=x	Specify 0 - 255 seconds test time-out

Table B-18. Remote Digital Loopback AT Commands

Front Panel	AT Command	Description
1=RDL IGNORED	&T5	RDL request from remote DSU ignored
2=RDL ACCEPTED	&T4	RDL request accepted

Table B-19. EIA Local Loopback AT Commands

Front Panel	AT Command	Description
1=DISABLED	_A0	EIA LLB disabled
2=ENABLED	_A1	EIA LLB enabled

Table B-20. EIA Remote Loopback AT Commands

Front Panel	AT Command	Description
1=DISABLED	_R0	EIA RLB disabled
2=ENABLED	_R1	EIA RLB enabled

Table B-21. AT Command for Storing Phone Numbers

AT Command	Description
&Zn=	Store Phone Number

Table B-22. AT Commands for Auto Answer

Front Panel	AT Command	Description
1=DISABLED	_J0	Auto Answer disabled
2=ENABLED	_J1	Auto Answer enabled

Table B-23. Test AT Commands

Front Panel Display	AT Command	Description
DTE & Loop (LL)	&T10	TD/RD and RX/TX Loopbacks
Loop Only (RT)	&T11	RX/TX Loopback at Network Interface
DTE Only	&T1	TX/RX Loopback at DTE Interface
DTE with TP	&T8	RX/RX Loopback with Test Pattern
Test Pattern	&T9	Transmit/Receive Test Pattern
Self Test	Z	Check Internal Components (Resets Unit)
Exit Test	&T0	Stops test, returns to data mode
TD = Customer Transmit Data RD = Customer Receive Data TX = Network Transmit Data RX = Network Receive Data		

Table B-24. DTE With Test Pattern Commands

Front Panel	AT Command	Description
1=2047 PATTERN	_T0&T8	Standard 2047 random data pattern.
2=511 PATTERN	_T1&T8	Standard 511 random data pattern.
3=STRESS PTRN #1	_T2&T8	Stress pattern with alternating high and low ones densities. Repeated pattern of 100 octets: 1111 1111; followed by 100 octets: 0000 0000.
4=STRESS PTRN #2	_T3&T8	Stress pattern with alternating medium and low ones densities. Repeated pattern of 100 octets: 0111 1110; followed by 100 octets: 0000 0000.
5=STRESS PTRN #3	_T4&T8	Stress pattern with medium ones density. Continuous series of octets: 0011 0010.
6=STRESS PTRN #4	_T5&T8	Stress pattern with low ones density. Continuous series of octets: 0100 0000.

Table B-25. Remote Tests and AT Commands

Front Panel	AT Command	Description
1=2047 PATTERN	_T0&T7	Standard 2047 random data pattern
2=511 PATTERN	_T1&T7	Standard 511 random data pattern
3=STRESS PTRN #1	_T2&T7	DDS Stress Pattern #1
4=STRESS PTRN #2	_T3&T7	DDS Stress Pattern #2
5=STRESS PTRN #3	_T4&T7	DDS Stress Pattern #3
6=STRESS PTRN #4	_T5&T7	DDS Stress Pattern #4
7=DATA FROM DTE	&T6	Data from DTE

Appendix C Default Configuration Profiles

DEFAULT CONFIGURATION PROFILES

The DSU III AR contains four different user profiles (Table C-1) or sets of configurations options stored in read-only memory (see Table C-2 on page C-2). The unit is shipped from the factory with profile 1 loaded into the nonvolatile configuration memory. See Chapter 2, *Installation* on page 2-1 and Chapter 9, *Manual Command* on page 9-1 for more information.

Table C-1. User Profiles

User Profile	Description
1	Profile 1 is configured for a 56 kbps, synchronous, point-to-point or dial up operation with a V.35 connector.
2	Use profile 2 for a 56 kbps, synchronous, point-to-point or dial up operation with an EIA-232 connector.
3	Use profile 3 for a SW56, asynchronous operation with CS and CD forced on.
4	Use profile 4 for a SW56 operation with DTR idle when off.

Table C-2. Default Configuration Profiles

	Profile Numbers			
	(00) 1	(01) 2	(02) 3	(03) 4
Manual Command				
Escape Character	43=2BH	43=2BH	43=2BH	43=2BH
CR Character	13=0DH	13=0DH	13=0DH	13=0DH
LF Character	10=0AH	10=0AH	10=0AH	10=0AH
BS Character	8	8	8	8
SW56 Abort Call Timer	50=32H	50=32H	50=32H	50=32H
Escape Guard Timer	50=32H	50=32H	50=32H	50=32H
Command Echo	Enable	Enable	Enable	Enable
Result Code	Enable	Enable	Enable	Enable
Long or Short Code	Long	Long	Long	Long
Test Pattern Type	2047	2047	2047	2047
CS Delay	Short	Short	Short	Short
DTR Recog. Delay (x2.5ms)	3	3	3	3
DTR Command Time-out (x1 sec)	8	8	8	8
Front Panel En/Dis	Enable	Enable	Enable	Enable
AT Password Control	Disable	Disable	Disable	Disable
Network Options				
Loop Rate	AUTO	AUTO	56k	AUTO
Network Address	0	0	0	0
Remote Conf. En/Dis	Enable	Enable	Enable	Enable
Network Type	Dedicated	Dedicated	AT&T/MCI SW56	AT&T/MCI SW56
Clock Source	From Network	From Network	From Network	From Network

Table C-2. Default Configuration Profiles (Continued)

	Profile Numbers			
	(00) 1	(01) 2	(02) 3	(03) 4
DTE Options				
Remote DSU Address	0	0	0	0
DTE Rate (56/64k loop)	Same as Loop	Same as Loop	Same as Loop	Same as Loop
Scrambler Mode	OFF	OFF	OFF	OFF
Connector Type	V.35	EIA232	EIA232	V.35
DTE Data Format	SYNC	SYNC	ASYN	SYNC
DTE Command Options	DIS	DIS	DIS	DIS
Transmit Clock	Normal	Normal	Normal	Normal
CS Options	Follow RS	Follow RS	Forced On	Follow RS
Anti-stream Timer	Timer Off	Timer Off	Timer Off	Timer Off
CD Options	Normal	Normal	Forced On	Normal
TR Options	Ignored	Ignored	Ignored	Idle When Off
SR Options	Off Test+OOS	Off Test+OOS	Off Test+OOS	Off Test+OOS
Secondary Channel Rate	OFF	OFF	OFF	OFF
Test Options				
Test Time-out	Off	Off	Off	Off
RDL En/Dis	RDL Accepted	RDL Accepted	RDL Accepted	RDL Accepted
EIA Controlled LLB	Disable	Disable	Disable	Disable
EIA Controlled RLB	Disable	Disable	Disable	Disable
Dial Options				
Auto Answer	Enable	Enable	Enable	Enable

EIA-232 Connector

56/64 KBPS APPLICATION

The EIA-232 connector, shown in Figure D-1, may be used for 56 and 64 kbps applications. Using the External clock option and this cable should eliminate data errors caused by excessive delays in the DTE transmit clock receiver and transmit data driver. When creating this cable at the DTE interface EIA-232 connector, tie transmit clock lead (TC) to external transmit (ETC) as shown.

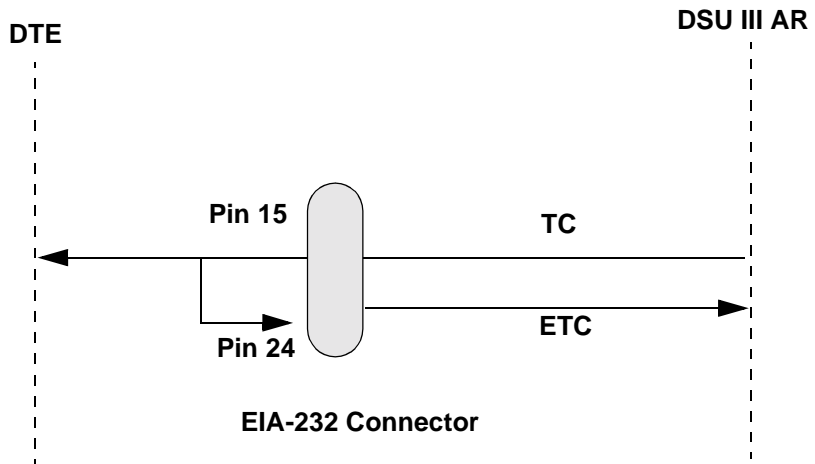

Figure D-1. EIA-232 Connector

Appendix E DSU to DSU Tail Circuit

MODEM TAIL CIRCUIT APPLICATION

A DDS Tail Circuit is a serial connection of two DDS circuits as shown in Figure E-1 on page E-2. The two circuits are joined at the DTE port interface of each DSU unit. A special tail circuit crossover cable is required so that transmit line connects to the receive line on the other DSU as well as the DTR, CTS, RTS, and CD signal lines get matched appropriately. Figure E-2 on page E-3 details the crossover cable wiring.

ADTRAN DSU/CSU units will operate in this configuration.



ADTRAN does not recommend the tail circuit mode due to the potential for clock slippage and data loss when using this configuration. Moreover, further problems can occur when each DDS circuit is using a different master clock source and will require additional hardware called a tail circuit buffer to reduce the risk of data overruns and clock slips.

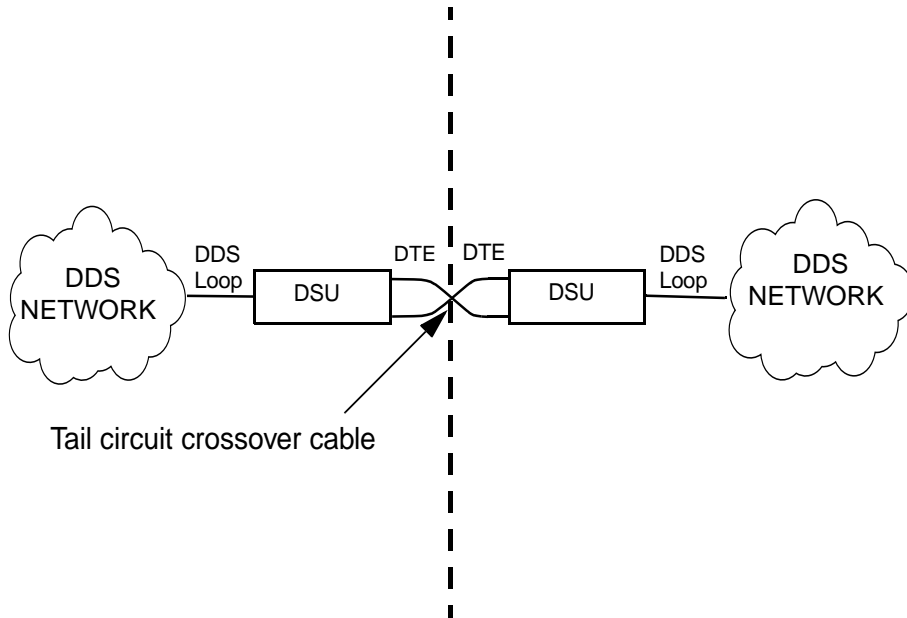

Figure E-1. DDS Tail Circuit

An EIA-232 DB-25 DSU tail circuit cable diagram for a DSU tail circuit application is shown in Figure E-2.

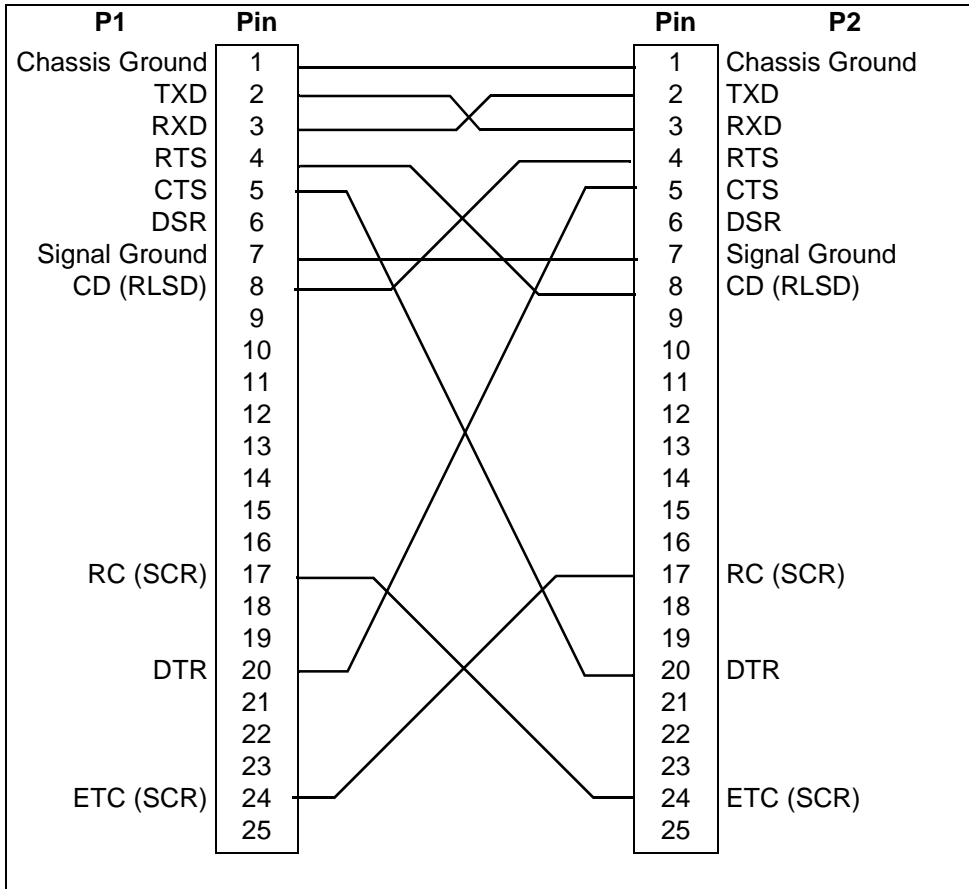

Figure E-2. Standard EIA-232-D Crossover Cable

Specifications Summary

SPECIFICATIONS AND FEATURES

This section describes the standard specifications and features incorporated in the DSU III AR.

Operating Modes

- Dedicated DDS (point-to-point, multipoint)
- DDSII DDS with secondary channel (point-to-point, multipoint) Switched 56 (4-wire)

Data Rates

- Dedicated mode service rate: 2.4, 4.8, 9.6, 19.2, 38.4, 56, and 64 kbps
- Switched mode service rate: 56 kbps

DTE Rates

- DTE rates match service rates
- DTE-to-loop rate matching in both dedicated and switched modes
- Synchronous rates: 2.4, 4.8, 9.6, 19.2, 38.4, 56, and 64 kbps
- Asynchronous rates: 2.4, 4.8, 9.6, 19.2, 38.4, and 57.6 kbps

FCC Approval

FCC part 15, class A and part 68

DTE Interfaces

Both EIA-232 and V.35 electrical and physical DTE interfaces

Data Buffering

Internal slack buffer

Clocking

- Normal DDS or private network tributary (slaved to network receive clock)
- Private network master (internal clock)
- Private network master (slaved to external DTE clock)

Switched Mode Dialing Options

- Stored number
- Front panel keypad
- DTR dialing of stored number
- In-band AT commands
- V.25 bis in-band dialing

Diagnostics

- Network: CSU and DSU loopbacks
- User: Local DTE and loop, remote V.54
- Test Patterns: 2047, 511, DDS, stress patterns 1 to 4

Line Requirements

- Loop transmission parameters as defined in:
- AT&T PUB 62310: Dedicated DDS
- AT&T PUB 41468: Switched 56
- SPRINT TS 0046: Switched 56

Line Interface

- RJ-48S, 4-wire, full duplex

Receiver Sensitivity

- -45 dB at all rates

Environment

- Operating Temperature: 0°C to 50°C (32°F to 122°F)
- Storage Temperature: -20°C to 70°C (-4°F to 158°F)
- Relative Humidity: Up to 95% non-condensing

Hardware Specifications

- Dimensions: 2.25"H, 8.75"W, 10.25"D
- Weight: 3 lbs
- Power: 115 VAC, 60 Hz, 8 W
- MTBF: 439,754 hours
- CLEI: DDSUJ602AA

Appendix G Acronyms/Abbreviations

ACK	acknowledgment
ALM	alarm
ANSI	American National Standards Institute
AR	access rate
ARP	address resolution protocol
async	asynchronous
BECN	backward explicit congestion notification
BOP	bit oriented protocol
CCITT	Consultive Committee for International Telephony and Telegraphy
CD	carrier detect
CIR	committed information rate
CO	central office
CPE	customer premise equipment
CR, C/R	command response
CRC	cyclic redundancy check
CS	clear to send
CSU	channel service unit
CTS	clear to send
dB	decibel
DBU	dial backup
DCD	data carrier detect

DCE	data communications equipment
DDS	digital data service
DE	discard eligible
DLCI	data link connection identifier
DSAP	destination service access point
DSR	data set ready
DSU	data service unit
DTE	data terminal equipment
DTR	data terminal ready
EA	extended address
EBCDIC	extended binary coded decimal interexchange code
FECN	forward explicit congestion notification
FEP	front end processor
FIFO	first in first out
FR	frame relay
FRAD	frame relay access device
FRF	frame relay forum
FSU	frame relay service unit
GUI	graphical user interface
HDLC	high-speed data link control
IA	inactive
IP	internet protocol
ISDN	integrated services digital network
ITU	International Telecommunications Union
KA	keep alive
kbps	kilobits per second
LAN	local area network
LED	light emitting diode
LI	link integrity

LLC	logical link control
LMI	local management interface
LRC	lateral redundancy check
MIB	management information base
ms	millisecond
OCU	office channel unit
OOS	out of service
PPP	point-to-point protocol
PU	physical unit
PVC	permanent virtual circuit
RD	receive data
RDL	remote digital loopback
RFC	request for comments
RFECN	remote forward explicit congestion notification
RIP	routing information protocol
RMA	return material authorization
RNR	receiver not ready
RR	receiver ready
RS	request to send; also recommended standard
RTS	request to send
Rx	receive
SAP	service access point
SDLC	synchronous data link control
SLIP	serial line internet protocol
SNA	systems network architecture
SNMP	simple network management protocol
SPID	service profile identifier
SR	data set ready
SVC	switched virtual circuit

SW56	switched 56
sync	synchronous
TD	transmit data
TR	data terminal ready
Tx	transmit
UA	unavailable
UNI	user-to-network interface
VRC	vertical redundancy check
WAN	wide area network

Appendix H Glossary

American National Standards Institute (ANSI)

Devices and proposes recommendations for international communications standards.

asynchronous

A method of data transmission which allows characters to be sent at irregular intervals by preceding each character with a start bit, followed by a stop bit.

backward explicit congestion notification (BECN)

A bit set by a frame relay network to notify an interface device (DTE) that congestion avoidance procedures should be initiated by the sending device.

bandwidth

The bandwidth determines the rate at which information can be sent through a channel (the greater the bandwidth, the more information that can be sent in a given amount of time).

bridge

A device that supports LAN-to-LAN communications. Bridges may be equipped to provide frame relay support to the LAN devices they serve. A frame relay capable bridge encapsulates LAN frames in frame relay frames and feeds them to a frame relay switch for transmission across the network. A frame relay capable bridge also receives frame relay frames from the network, strips the frame relay frame off each LAN frame, and passes the LAN frame on to the end device. Bridges are generally used to connect LAN segments to other LAN segments or to a WAN. They route traffic on the Level 2 LAN protocol (e.g. the Media Access Control address), which occupies the lower sub-layer of the LAN OSI data link layer. See also router.

CD

carrier detect. A signal generated by a modem or DSU/CSU. CD indicates the presence of a carrier signal on a communications link.

channel service unit

CSU. A device used to connect a digital phone line (T1 or Switched 56 line) coming in from the phone company to either a multiplexer, channel bank, or directly to another device producing a digital signal; for example, a digital PBX, a PC, or data communications device. A CSU performs certain line-conditioning and equalization functions, and responds to loopback commands sent from the central office. A CSU regenerates digital signals. It monitors them for problems, and provides a way of testing the digital circuit.

CIR

committed information rate. Less than or equal to the access rate, the CIR is used by the service provider for rate enforcement when the network is congested. When rates exceed the CIR, frames may be discarded.

clocking

An oscillator-generated signal that provides a timing reference for a transmission link. A clock provides signals used in a transmission system to control the timing of certain functions. The clock has two functions, (1) to generate periodic signals for synchronization and (2) to provide a time base.

CPE

customer premise equipment. All telecommunications terminal equipment located on the customer premises, including telephone sets, private branch exchanges (PBXs), data terminals, and customer-owned coin-operated telephones.

C/R bit

In the Q.921 protocols, a bit that identifies a data-link-layer frame as either a command or a response.

CRC

cyclic redundancy check. A computational means to ensure the accuracy of frames transmitted between devices in a frame relay network. The mathematical function is computed, before the frame is transmitted, at the originating device. Its numerical value is computed based on the content of the frame. This value is compared with a recomputed value of the function at the destination device.

CS

See CTS.

CSU

See channel service unit.

CTS

clear to send. A signal on the DTE interface indicating that the DCE is clear to send data.

DBU

dial backup. Providing a secondary, switched dial service to route data upon primary link failure.

data service unit

DSU. A device designed to transmit and receive digital data on digital transmission facilities.

dB

decibel. A unit of measure of signal strength, usually the relation between a transmitted signal and a standard signal source.

data communications equipment (DCE)

Device that provides all the functions required for connection to telephone company lines and for converting signals between telephone lines and DTE. Also see DTE.

DDS

digital data service. A private line digital service, for transmitting data end-to-end at speeds of 2.4, 4.8, 9.6, and 56 kbps and in some cases 19.2, 38.4, or 64 kbps. The systems can use central hub offices for obtaining test access, bridging legs of multipoint circuits, and cross connecting equipment. DDS is offered on an inter-LATA basis by AT&T and on an inter-LATA basis by the Bell operating companies.

data link connection identifier (DLCI)

A unique number assigned to a PVC end point in a frame relay network. Identifies a particular PVC endpoint within a user's access channel in a frame relay network and has local significance only to that channel.

discard eligibility (DE)

A user-set bit indicating that a frame may be discarded in preference to other frames if congestion occurs, to maintain the committed quality of service within the network. Frames with the DE bit set are considered Be excess data.

DSU

See data service unit.

DSU loopback

A telco initiated test which loops the DSU back to the telco and is used to test the DDS circuit as well as the DSU/CSU.

DTE

data terminal equipment. The end-user terminal or computer that plugs into the termination point (DCE) of a communications circuit. The main difference between the DCE and the DTE is that pins two and three are reversed.

end device

The ultimate source or destination of data flowing through a frame relay network sometimes referred to as DTE. As a source device, it sends data to an interface device for encapsulation in a frame relay frame. As a destination device, it receives de-encapsulated data (i.e., the frame relay frame is stripped off, leaving only the user's data) from the interface device.

encapsulation

A process by which an interface device places an end device's protocol-specific frames inside a frame relay frame. The network accepts only frames formatted specifically for frame relay; therefore interface devices acting as interfaces to a frame relay network must perform encapsulation. See also interface device and frame-relay-capable interface device.

file server

In the context of frame relay network supporting LAN-to-LAN communications, a device connecting a series of workstations within a given LAN. The device performs error recover and flow control functions as well as end-to-end acknowledgment of data during data transfer, thereby significantly reducing overhead within the frame relay network.

forward explicit congestion notification (FECN)

A bit set by a frame relay network to notify an interface device (DTE) that congestion avoidance procedures should be initiated by the receiving device. See also BECN.

frame check sequence (FCS)

The standard 16-bit cyclic redundancy check used for HDLC and frame relay frames. The FCS detects bit errors occurring in the bits of the frame between the opening flag and the FCS, and is only effective in detecting errors in frames no larger than 4096 octets. See also cyclic redundancy check (CRC).

frame-relay-capable interface device

A communications device that performs encapsulation. Frame-relay-capable routers and bridges are examples of interface devices used to interface the customer's equipment to frame relay network. See also interface device and encapsulation.

frame relay frame

A variable-length unit of data, in frame-relay format that is transmitted through a frame relay network as pure data. Contrast with packet.

frame relay network

A telecommunications network based on frame relay technology. Data is multiplexed. Contrast with packet switching network.

gateway

A device which enables information to be exchanged between two dissimilar systems or networks.

high level data link control (HDLC)

A generic link-level communications protocol developed by the International Organization for Standardization (ISO). HDLC manages synchronous code-transparent, serial information transfer over a link connection. See also synchronous data link control (SDLC).

host computer

The primary or controlling computer in a multiple computer operation.

in-band

Signaling (dialing, diagnostics, management, configuration, etc.) over the same channel used for data.

ingress

Frame relay frames leaving from an access device in a direction toward the frame relay network.

interface device

Provides the interface between the end device(s) and a frame relay network by encapsulating the user's native protocol in frame relay frames and sending the frames across the frame relay backbone. See also encapsulation and frame-relay-capable interface device.

IP

internet protocol. A protocol which provides for transmitting blocks of data between hosts identified by fixed-length addresses.

ISDN

integrated services digital network. A network architecture that enables end-to-end digital connections. The network supports diverse services through integrated access arrangements and defines a limited set of standard, multipurpose interfaces for equipment vendors, network providers, and customers. Interworking with a public switched telephone network is retained.

local area network (LAN)

A privately owned network that offers high-speed communications channels to connect information processing equipment in a limited geographic area.

MIB

management information base. A database of network management information used by SNMP.

multi-point

A configuration or topology designed to transmit data between a central site and a number of remote terminals on the same circuit. Individual terminals will generally be able to transmit to the central site but not to each other.

out-of-band

Signaling that is separated from the channel carrying information (voice, data, video, etc.). Typically the separation is accomplished by a filter. The signaling includes dialing and other supervisory signals.

packet

A message containing both control information and data. The control information is used for routing the packet through a network to its final destination. Contrast with frame relay frame.

packet-switching network

A telecommunications network based on packet-switching technology, wherein a transmission channel is occupied only for the duration of the transmission of the packet. Contrast with frame relay network.

parameter

A numerical code that controls an aspect of terminal and/or network operation. Parameters control such aspects as page size, data transmission speed, and timing options.

permanent virtual circuit (PVC)

A frame relay logical link, whose endpoints and class of service are defined by network management. Analogous to an X.25 permanent virtual circuit, a PVC consists of the originating frame relay network element address, originating data link control identifier, terminating frame relay network element address, and termination data link control identifier. Originating refers to the access interface form which the PVC is initiated. Terminating refers to the access interface at which the PVC stops. Many data network customers require a PVC between two points. Data terminating equipment with a need form continuous communion use PVCs. See also data link connection identifier (DLCI).

ping

An internet protocol standard that provides loopback on demand for any device in an IP network. One device "pings" another by sending a loopback request to the device's IP address.

point-to-point

Type of communications link that connects a single device to another single device, such as a remote terminal to a host computer.

remote configuration

A feature designed into ADTRAN DSU/CSU products that allow remote DSU/CSU to be configured from a local DSU/CSU or VT-100 compatible terminal.

router

A device that supports LAN-to-LAN communications. Routers may be equipped to provide frame relay support to the LAN devices they serve. A frame-relay-capable router encapsulates LAN frames in a frame relay frames and feeds those frame relay frames to a frame relay switch for transmission across the network. A frame-relay-capable router also receives frame relay frames from the network, strips the frame relay frame off each frame to produce the original LAN frame, and passes the LAN frame on to the end device. Routers connect multiple LAN segments to each other or to a WAN. Routers route traffic on the Level 3 LAN protocol (e.g., the internet protocol address). See also bridge.

sealing current

A designation for a powering situation that consists of a wet loop without span power.

service

The provision of telecommunications to customers by a common carrier, administration, or private operating agency, using voice, data, and/or video technologies.

SNA

systems network architecture. The IBM protocol group which governs main-frame communication.

SNMP

simple network management protocol. A control and reporting scheme widely used to manage devices from different vendors. SNMP operates on top of the Internet protocol.

SPID

service profile IDentifier. A sequence of digits identifying ISDN terminal equipment to the ISDN switch when more than one ISDN set has been attached to the same central office. The SPID is assigned by the telco when the ISDN line is installed and normally resembles a phone number.

SR

data set ready. A signal on the EIA-232 interface that indicates if the communications is connected and ready to start handshaking control signals so communications can begin.

statistical multiplexing

Interleaving the data input of two or more devices on a single channel or access line for transmission through a frame relay network. Interleaving of data is accomplished using the DLCI.

switched network

The network of dial-up telephone lines using circuit switching to provide communications services to network users.

synchronous

Communications in which the timing is achieved by sharing a single clock. Each end of the transmission synchronizes itself with the use of clocks and information sent along with the transmitted data.

synchronous data link control (SDLC)

A link-level communications protocol used in an international business machines (IBM) systems Network Architecture (SNA) network that manages synchronous, code-transparent, serial information transfer over a link connection. SDLC is a subset of the HDLC protocol developed by ISO.

TELNET

The standard TCP/IP remote login protocol specified in RFC-854.

VT-100

A non-intelligent terminal or terminal emulation mode used for asynchronous communications. Used to configure the DSU IQ.

Index

Numerics

56/64 kbps application, D-1

A

ACES help desk, xi

affidavit

- for connection of CPE equipment, viii
- for requirements for connection to digital services, v

anti-stream option, 6-12

Applications engineering

- how to contact, xi

AT commands

- clear to send (CS) B-6
- data format B-5
- data set ready (SR) B-7
- scrambler on/off B-5
- secondary rate B-8
- storing phone numbers B-9
- test timeout B-8
- transmit clock B-5

AT commands, 4-5

auxiliary EIA-232 2-3

auxiliary port, 6-16

C

call request using stored number (CRS), 4-11

call request with number (CRN), 4-10

Canadian emissions requirements, vii

Canadian equipment limitations vi

cancel key, on front panel, 3-5

CAPS department

- how to contact, xii

carrier detect (CD) 6-13

carrier detect options, 6-13

clear to send (CS)

- AT commands B-6

clear to send options menu, 6-10

clock source 5-6

clock source commands, B-4

clocking

- specifications, F-2

configuration 2-4

- dial options, 8-1

- DTE options 6-1

- local 4-2

- network options 5-1

- test options 7-1

configuration local (CNL), 4-10

configuration menu, 3-2

configuration methods, 4-2

configuration remote (CNR) 4-10

connect incoming call (CIC), 4-9

connector

- EIA-232 D-1

connector type for DTE, 6-5

connector type option, 6-5

customer service, xi

D

data buffering

- specifications, F-2

data format

- AT commands B-5

data format for DTE interface, 6-6

data service rates

- specifications, F-1

data set ready (SR)

- AT commands B-7

data set ready (SR) options, 6-15

data terminal ready (TR) menu, 6-14

- DDS network status messages, 12-3
- DDS tail circuit, E-1
- diagnostic testing, 11-1
- diagnostics
 - specifications, F-2
- dial backup
 - configuration 8-1
- dial menu, 3-2
- dial options
 - auto answer, 8-2
 - phone number storage, 8-1
- dial options menu, 8-1
- dial selection 10-1
- digital data service (DDS) 1-1, 5-6
- disregard incoming call (DIC), 4-11
- DSU operational status messages, 12-2
- DSU/CSU status messages, 11-5
- DTE and Loop test, 11-12
- DTE command option 6-7
- DTE connectors 2-3
- DTE control leads and status messages, 12-4
- DTE data connection 2-4
- DTE interface 2-3
- DTE interface parameters 4-1
- DTE interfaces
 - specifications, F-1
- DTE only test, 11-16
- DTE options menu, 6-1
- DTE rate
 - over 56/64 kbps loop, 6-2
- DTE Rate/Mode status message, 12-4
- DTE rates
 - specifications, F-1

E

- EIA local loopback, 7-3
- EIA remote loopback, 7-4
- EIA-232 connector D-1
- EIA-232 interface 1-1
- enter dial number option, 10-2
- enter key, on front panel, 3-5
- environmental
 - specifications, F-3
- exiting a test, 11-3
- external clock 6-9

F

- FCC approval
 - specifications, F-1

- FCC radio frequency interference statement, v
- FCC regulations, iv
- Front panel
 - description of, 3-5
- front panel
 - LED descriptions, 3-6
- front panel menu structure,
 - menu for front panel, 3-1
- function keys for menu travel, 3-3

H

- help desk
 - how to contact, xi

I

- installation 2-1

L

- LCD window on front panel, 3-5
- LED descriptions, on front panel, 3-6
- line interface
 - specifications, F-2
- line requirements
 - specifications, F-2
- local configuration, about, 4-1
- local unit diagnostics, 11-10
- loop only (RT) test, 11-14
- loop rate option, 5-1

M

- main menu 3-1, 3-6
- manual command 4-1
- manual command option, 9-1
- menu travel, 3-3
- modem tail circuit application, E-1

N

- network
 - interface connection 2-4
- network address 5-3
- network interface parameters, 4-1
- network options 5-1
 - for loop operation, 5-1
- network rate status message, 12-4
- numeric keypad, on front panel, 3-5

O

- operating modes

specifications F-1
operation 3-1

P

phone number storage
AT commands B-9
pinouts
auxiliary EIA-232 connector, A-4
primary EIA-232 connector, A-2
primary V.35 connector, A-3
telco connector, A-1
point-to-point operation 6-4
power cord 2-3
power switch 2-3
power up 2-2
primary EIA-232 2-3
primary V.35 2-3
product support, xi
product warranty, x
program number (PRN), 4-11

Q

quick key, on front panel, 3-6

R

rear panel 2-3
receiver sensitivity
specifications, F-2
redial last number option, 10-2
remote configuration
AT commands B-2, B-3
enable/disable 5-4
remote configuration, about, 4-1
remote digital loopback (RDL) option, 7-2
repair and return information, xii
request list of numbers (RLN), 4-12
RMA requests xi

S

safety instructions, vii
scrambler on/off 6-3
AT commands B-5
secondary channel 2-3
connection 2-4
services 2-3
secondary rate
AT commands B-8
secondary rate options, 6-16
self test option, 11-22

serial connection
of two DDS circuits, E-1
service type information iv
shift key, on front panel, 3-6
specifications, F-1
status menu, 3-2
switched 56 operation, 4-10
switched mode dialing options
specifications, F-2

T

technical support
how to contact, xi
telco jack 2-3
test AT commands, 11-10
test menu, 3-2
test options
configuration 7-1
test options menu, 7-1
test pattern option, 11-20
test time-out 7-1
test timeout
AT commands B-8
testing
diagnostic, troubleshooting, 11-1
timing source, 5-6
trademark information, ii
training information
how to contact, xii
transmit clock 6-8
AT command B-5
troubleshooting
test sequence for new installs or existing circuits, 11-8
troubleshooting new installs 11-6

U

unit dialing options, 4-1
unit test options, 4-1
up and down arrows, on front panel, 3-5
user profiles 4-1

V

V.25 bis commands 4-7
asynchronous option 4-8
bi-sync option 4-7
possible responses to, 4-9
SDLC option 4-7
V.35 connector 2-4

VALA 4-9

W

warranty, x