

DSU III DBU

Data Service Unit

Part Number 1200037L1

Document Number 61200037L1-20A

January 2000

Part Number	Version
1200037L1	Switched 4-Wire Version
1202037L1	Switched 4-Wire Version Second Generation
1200037L2	V.32 Version
1202037L2	V.32 Version Second Generation
1200037L3	Switched 2-Wire Version
1202037L3	Switched 2-Wire Version Second Generation
1200037L4	ISDN Version
1202037L4	ISDN Version Second Generation
1202037L5	V.34 Version

The logo for ADTRAN, featuring the word "ADTRAN" in a bold, stylized, sans-serif font. The letters are black with a white outline, and the entire logo is underlined with a thick black horizontal bar.

Trademarks:

DATAPATH is a registered trademark of CAE Electronics and is used by Northern Telecom under license.

Hayes is a registered trademark of Hayes Microcomputer Products, Inc.



901 Explorer Boulevard
P.O. Box 140000
Huntsville, AL 35814-4000
(256) 963-8000

© 2000 ADTRAN, Inc.
All Rights Reserved.
Printed in U.S.A.



Notes provide additional useful information.



Cautions signify information that could prevent service interruption.

WARNING

Warnings provide information that could prevent damage to the equipment or endangerment to human life.

IMPORTANT SAFETY INSTRUCTIONS

Save These Instructions

When using your telephone equipment, please follow these basic safety precautions to reduce the risk of fire, electrical shock, or personal injury:

1. Do not use this product near water, such as near a bath tub, wash bowl, kitchen sink, laundry tub, in a wet basement, or near a swimming pool.
2. Avoid using a telephone (other than a cordless-type) during an electrical storm. There is a remote risk of shock from lightning.
3. Do not use the telephone to report a gas leak in the vicinity of the leak.
4. Use only the power cord, power supply, and/or batteries indicated in the manual. Do not dispose of batteries in a fire. They may explode. Check local codes for any special disposal instructions.

FCC regulations require that the following information be provided in this manual:

1. This equipment complies with Part 68 of the FCC rules. On the bottom of the equipment housing is a label that shows the FCC registration number and Ringer Equivalence Number (REN) for this equipment. If requested, provide this information to the telephone company.
2. If this equipment causes harm to the telephone network, the telephone company may temporarily discontinue service. If possible, advance notification is given; otherwise, notification is given as soon as possible. The telephone company will advise the customer of the right to file a complaint with the FCC.
3. The telephone company may make changes in its facilities, equipment, operations, or procedures that could affect the proper operation of this equipment; advance notification and the opportunity to maintain uninterrupted service is given.
4. If experiencing difficulty with this equipment, please contact ADTRAN for repair and warranty information. The telephone company may require this equipment to be disconnected from the network until the problem is corrected or it is certain the equipment is not malfunctioning.
5. This unit contains no user serviceable parts.
6. An FCC compliant telephone cord with a modular plug is provided with this equipment. This equipment is designed to be connected to the telephone network or premises wiring using an FCC compatible modular jack, which is Part 68 compliant.
7. The following information may be required when applying to the local telephone company for leased line facilities.

Service Type	Digital Facility Interface Code	Service Order Code	Network Jacks
2.4 kbps Digital Interface	04DU5-24	6.0F	RJ-48S
4.8 kbps Digital Interface	04DU5-48	6.0F	RJ-48S
9.6 kbps Digital Interface	04DU5-96	6.0F	RJ-48S
19.2 kbps Digital Interface	04DU5-19	6.0F	RJ-48S
38.4 kbps Digital Interface	04DU5-38	6.0F	RJ-48S
56 kbps Digital Interface	04DU5-56	6.0F	RJ-48S
64 kbps Digital Interface	04DU5-64	6.0F	RJ-48S

8. The following information may be required when applying to the local telephone company for a dial-up line for the V.34 or V.32:

Service Type	REN	FIC	USOC
Loop Start (V.32)	0.3B	02LS2	RJ-11C
Loop Start (V.34)	0.8B	02LS2	RJ-11C

9. The REN is useful in determining the quantity of devices you may connect to your telephone line and still have all of those devices ring when your number is dialed. In most areas, the sum of the RENs of all devices should not exceed five. To be certain of the number of devices you may connect to your line as determined by the REN, call your telephone company to determine the maximum REN for your calling area.
10. This equipment may not be used on coin service provided by the telephone company. Connection to party lines is subject to state tariffs. (Contact your state public utility commission or corporation commission for information.)

FEDERAL COMMUNICATIONS COMMISSION RADIO FREQUENCY INTERFERENCE STATEMENT

This equipment has been tested and found to comply with the limits for a Class A digital device, pursuant to Part 15 of the FCC Rules. These limits are designed to provide reasonable protection against harmful interference when the equipment is operated in a commercial environment. This equipment generates, uses, and can radiate radio frequency energy and, if not installed and used in accordance with the instructions, may cause harmful interference to radio frequencies. Operation of this equipment in a residential area is likely to cause harmful interference in which case the user will be required to correct the interference at his own expense.



Shielded cables must be used with this unit to ensure compliance with Class A FCC limits.



Changes or modifications to this unit not expressly approved by ADTRAN will void the user's authority to operate the equipment.

CANADIAN EMISSIONS REQUIREMENTS

This digital apparatus does not exceed the Class A limits for radio noise emissions from digital apparatus as set out in the interference-causing equipment standard entitled "Digital Apparatus," ICES-003 of the Department of Communications.

Cet appareil numérique respecte les limites de bruits radioélectriques applicables aux appareils numériques de Class B prescrites dans la norme sur le matériel brouilleur: "Appareils Numériques," NMB-003 édictée par le ministre des Communications.

CANADIAN EQUIPMENT LIMITATIONS

Notice: The Canadian Industry and Science Canada label identifies certified equipment. This certification means that the equipment meets certain telecommunications network protective, operational, and safety requirements. The Department does not guarantee the equipment will operate to the user's satisfaction.

Before installing this equipment, ensure that it is permissible to be connected to the facilities of the local telecommunications company. The equipment must also be installed using an acceptable method of connection. In some cases, the company's inside wiring associated with a single-line individual service may be extended by means of a certified connector assembly (telephone extension cord). Compliance with the above conditions may not prevent degradation of service in some situations.

Repairs to certified equipment should be made by an authorized Canadian maintenance facility designated by the supplier. Any repairs or alterations made by the user to this equipment, or equipment malfunctions, may give the telecommunications company cause to request the user to disconnect the equipment.

Users should ensure for their own protection that the electrical ground connections of the power utility, telephone lines, and internal metallic water pipe system, if present, are connected together. This precaution may be particularly important in rural areas.



Users should not attempt to make such connections themselves, but should contact the appropriate electric inspection authority, or an electrician, as appropriate.

The **Load Number (LN)** assigned to each terminal device denotes the percentage of the total load to be connected to a telephone loop which is used by the device, to prevent overloading. The termination on a loop may consist of any combination of devices subject only to the requirement that the total of the Load Numbers of all devices does not exceed 100.

ISDN Service Ordering Information for the ADTRAN DSU III DBU Dial Backup

For ADTRAN DSU III DBU ISDN applications, the following guide can be used as an aid in ordering basic ISDN service from your local telephone company. The ADTRAN DSU III DBU ISDN includes NT1 and Terminal adapter functionality and supports data rates up to 64 kpbs.

Request an ISDN Basic Rate Interface (BRI) line with the following features:

U-interface reference point
2B1Q line coding
1B+D Service (supports up to 64 kbps)

The DSU III DBU ISDN supports the following switch types and software protocols:

AT&T 5ESS	Custom, 5E6 and later software, National ISDN-1
NT1 DMS-100	BCS-32 and later software (Pvc1), National ISDN-1 (Pvc2)
Siemens EWSD	National ISDN-1

Request that the ISDN line allocate one DYNAMIC Terminal End-point Identifier (TEI) for the number.

For service offered from an AT&T 5ESS, request a point-to-point line with the following features:

Feature: Value
B1 Service: On Demand (DMD)
Data Line Class:Point-to-Point
Maximum B Channels: 1 (1B+D)
Circuit Switched Data (CSD) Bearer Channels: Any
Number of CSD Calls: 1 (1B+D)
Terminal Type: Type A

Turn the following features off:

Packet Mode Data
Multi-line Hunt
Multiple Call Appearances
Electronic Key Telephone Sets (EKTS)
Shared Dictionary Numbers
Accept Special Type of Number
Intercom Groups
Network Resource Selector (Modem Pools)
Message Waiting
Hunting
InterLata Competition

For service offered from a Northern Telecom DMS-100, request a Point-to-Point Multi-Point line with the following features:

Line Type: Basic Rate, Functional
Electronic Key Telephone Sets (EKTS): No
Call Appearance Handling (CACH): No
Non-Initializing Terminal: No
Circuit Switched Service: Yes
Packet Switched Service: No
TEI: Dynamic
Bearer Service: Circuit Switched voice and data permitted on any B channel (packet mode data not permitted)

WARRANTY AND CUSTOMER SERVICE

ADTRAN will replace or repair this product within five years from the date of shipment if it does not meet its published specifications or fails while in service. For detailed warranty, repair, and return information refer to the ADTRAN Equipment Warranty and Repair and Return Policy Procedure.

Return Material Authorization (RMA) is required prior to returning equipment to ADTRAN.

For service, RMA requests, or further information, contact one of the numbers listed in the back of this manual.

LIMITED PRODUCT WARRANTY

ADTRAN warrants that for ten (10) years from the date of shipment to Customer, all products manufactured by ADTRAN will be free from defects in materials and workmanship. ADTRAN also warrants that products will conform to the applicable specifications and drawings for such products, as contained in the Product Manual or in ADTRAN's internal specifications and drawings for such products (which may or may not be reflected in the Product Manual). This warranty only applies if Customer gives ADTRAN written notice of defects during the warranty period. Upon such notice, ADTRAN will, at its option, either repair or replace the defective item. If ADTRAN is unable, in a reasonable time, to repair or replace any equipment to a condition as warranted, Customer is entitled to a full refund of the purchase price upon return of the equipment to ADTRAN. This warranty applies only to the original purchaser and is not transferable without ADTRAN's express written permission. This warranty becomes null and void if Customer modifies or alters the equipment in any way, other than as specifically authorized by ADTRAN.

EXCEPT FOR THE LIMITED WARRANTY DESCRIBED ABOVE, THE FOREGOING CONSTITUTES THE SOLE AND EXCLUSIVE REMEDY OF THE CUSTOMER AND THE EXCLUSIVE LIABILITY OF ADTRAN AND IS IN LIEU OF ANY AND ALL OTHER WARRANTIES (EXPRESSED OR IMPLIED). ADTRAN SPECIFICALLY DISCLAIMS ALL OTHER WARRANTIES, INCLUDING (WITHOUT LIMITATION), ALL WARRANTIES OF MERCHANTABILITY AND FITNESS FOR A PARTICULAR PURPOSE. SOME STATES DO NOT ALLOW THE EXCLUSION OF IMPLIED WARRANTIES, SO THIS EXCLUSION MAY NOT APPLY TO CUSTOMER.

In no event will ADTRAN or its suppliers be liable to Customer for any incidental, special, punitive, exemplary or consequential damages experienced by either Customer or a third party (including, but not limited to, loss of data or information, loss of profits, or loss of use). ADTRAN is not liable for damages for any cause whatsoever (whether based in contract, tort, or otherwise) in excess of the amount paid for the item. Some states do not allow the limitation or exclusion of liability for incidental or consequential damages, so the above limitation or exclusion may not apply to Customer.

Table of Contents

Chapter 1. Introduction

pRодукt Overview	1-1
DDS Operation	1-3
Dial Backup Operation	1-4
Dial Backup Options	1-4
4-Wire Switched 56 Backup Option	1-4
2-Wire Switched 56 Backup Option	1-4
V.32 bis Backup Option	1-4
V.34 Backup Option	1-5
1B+D Basic Rate ISDN Backup Option	1-5
Entering Dial Backup Mode	1-5
Operation During Critical Times	1-5
Loss of Sealing Current	1-5
Out of Service (OOS) Signal	1-6
No Receive Signal	1-6
All 1s or all 0s Condition	1-6
Operation During Noncritical Times	1-6
Conditions for Returning to the DDS Circuit	1-6

Chapter 2. Installation

Unpack, Inspect, Power Up	2-1
Receipt Inspection	2-1
ADTRAN Shipments Include	2-1
Customer Provides	2-1
Power Up	2-2
Network Interface Connection	2-2
DTE Data Connection/Primary DTE	2-3
Secondary Channel Connection	2-6
Configuration	2-7
Configuration Methods	2-7
AT Commands	2-7
V.25 bis Commands	2-8
SDLC Option	2-8

- Character Format 2-9
- Command Structure 2-9
- Bi-Sync Option 2-9
 - Character Format 2-9
 - Command Structure 2-9
- Asynchronous Option 2-9
 - Character Format 2-9
 - Command Structure 2-9
- Command Descriptions 2-10
- Syntax and Possible Responses 2-10
 - CNL (Configuration Local) 2-10
 - CNR (Configuration Remote) 2-11
- Remote Command 2-11

Chapter 3. Operation

- Menu Structure 3-1
 - Main Menu 3-1
 - Status 3-1
 - Test 3-2
 - Configuration (CONFIG) 3-2
 - Dial 3-2
 - Basic Menu Navigation 3-2
- Front Panel 3-4
 - LCD Window 3-4
 - Enter 3-4
 - Numeric Keypad 3-4
 - Shift 3-5
 - Quick 3-5
 - Cancel 3-5
 - Up and Down Arrows 3-5
 - LED Description 3-5
- Rear Panel 3-6

Chapter 4. Configuration Overview

- Local and Remote Configuration 4-1

Chapter 5. Configuring Network Options

- Network Options 5-1
 - Loop Rate 5-3
 - Network Address 5-4

Remote Configuration	5-4
Clock Source	5-5

Chapter 6. Configuring DTE Options

DTE OptioNS	6-1
DTE Rate	6-1
Connector Type	6-4
Data Format	6-5
DTE Command Option	6-6
Transmit Clock	6-7
Clear to Send (CS) Options	6-8
Anti-Stream	6-10
CD Options	6-11
Data Terminal Ready (TR) Options	6-12
Data Set Ready (SR) Options	6-13
Secondary Rate	6-14

Chapter 7. Configuring Test Options

Test Options	7-1
Test Timeout	7-2
Remote Digital Loopback (RDL)	7-2
EIA LLB	7-3
EIA RLB	7-3
DBU Answer Test	7-4

Chapter 8. Configuring Dial Options

Dial Options	8-1
Phone Number	8-3
ISDN Dial Backup	8-3
Setting the Service Profile Identifier (SPID)	8-3
Setting the Local Directory (LOC) Number	8-4
DBU Options for All Models	8-4
Automatic DBU	8-4
Number to Dial	8-4
Originate/Answer	8-5
When Out of Service (OOS)	8-5
No Receive (RX) Signal	8-5
No Sealing Current	8-5
When all 1s/0s	8-5
Auto Restore	8-5

- Redial Counter 8-6
- Fail Timer 8-6
- Wait to Redial 8-6
- DBU Options for 2-wire and 4-wire 8-8
 - Network Type 8-8
- DBU Options for V.32 bis and V.34 8-8
 - Error Control 8-8
 - Flow Control 8-8
 - Compression 8-8
- DBU Options for ISDN 8-10
 - Switch Type 8-10
- DBU Passcode 8-10

Chapter 9. Dial Options

- dial Options 9-1
 - Answer Unit Connected to DDS Line 9-2
 - Dial Backup 9-2
 - Originate Unit Connected to DDS Line 9-2
 - Dial Backup 9-2
 - Stay on Leased 9-2
 - DBU Online Test 9-2
 - Dial Options During Dial Backup 9-2
 - Hang Up 9-2
 - Stay On Line 9-3

Chapter 10. Status

- Status 10-1
 - Network Rate, DTE Rate, and Data Format 10-1
 - Dial Backup Information 10-2
 - Type of Dial Backup Service 10-2
 - Current Status of Dial Backup Mode 10-2
 - DSU Operation and Network Status 10-3
 - Current DSU III DBU Status 10-3
 - Current DDS Network Status 10-4
 - DTE Control Leads and Status 10-4

Chapter 11. Testing and Troubleshooting

- TEST OVERVIEW 11-1
 - Initiating a Test 11-2
 - Test Status Display 11-3

Exiting a Test	11-3
Troubleshooting	11-5
Messages from the DSU/CSU	11-5
Troubleshooting New Installs	11-6
Test Sequence for Troubleshooting New Installs or Existing Circuits	11-7
Local Unit diagnostics	11-8
DTE & Loop (LL)	11-10
Test Description	11-10
Test Purpose	11-10
Initiating	11-11
Interpreting Test Results	11-11
Loop Only (RT)	11-12
Test Purpose	11-12
Initiating	11-12
Interpreting Test Results	11-13
DTE Only	11-14
Test Purpose	11-14
Initiating	11-14
Interpreting Test Results	11-15
DTE With Test Pattern	11-16
Test Purpose	11-16
Initiating	11-16
Interpreting Test Results	11-17
Test Pattern	11-18
Test Purpose	11-18
Initiating	11-19
Interpreting Test Results	11-19
Self Test	11-20
Test Purpose	11-20
Initiating	11-20
Interpreting Test Results	11-20
Remote Unit Diagnostics	11-21
Test Purpose	11-21
Initiating	11-22
Test Results	11-22
Interpreting Test Results	11-22
DBU Connection	11-23
Test Purpose	11-23
Initiating	11-24
Interpreting Test Results	11-24

Chapter 12. Manual Command
Manual Command 12-1

Appendix A. AT Commands..... A-1

Appendix B. Default Configuration Profiles B-1

Appendix C. DSU to Modem Interconnect C-1

Appendix D. EIA-232 Connector D-1

Appendix E. Specifications Summary E-1

Appendix F. Glossary F-1

List of Figures

Figure 1-1.	Typical Point-to-Point Application for DSU III DBU	1-2
Figure 3-1.	Example of Basic Menu Navigation	3-3
Figure 3-2.	DSU III DBU Front View	3-4
Figure 3-3.	DSU III DBU Rear View	3-7
Figure 5-1.	Setting Loop Rate Options	5-3
Figure 5-2.	Setting the Network Address.	5-4
Figure 5-3.	Remote Configuration.	5-4
Figure 5-4.	Setting the Clock Source	5-5
Figure 6-1.	Selecting DTE Rates.	6-2
Figure 6-2.	Selecting the Connector Type.	6-4
Figure 6-3.	Selecting Asynchronous or Synchronous Data Format . .	6-5
Figure 6-4.	Selecting DTE Command Option	6-6
Figure 6-5.	Transmit Clock Options	6-7
Figure 6-6.	Selecting CS Options	6-8
Figure 6-7.	Anti-Stream Options	6-10
Figure 6-8.	Selecting CD Options	6-11
Figure 6-9.	Selecting Data Terminal Ready (TR) Options	6-12
Figure 6-10.	Setting Data Set Ready (SR) Options	6-13
Figure 6-11.	Setting the Secondary Rate.	6-14
Figure 7-1.	Setting Test Timeout Option	7-2
Figure 7-2.	Remote Digital Loopback	7-2
Figure 7-3.	EIA Local Loopback Options	7-3
Figure 7-4.	EIA Remote Loopback Options	7-3
Figure 7-5.	DBU Answer Test Option.	7-4
Figure 8-1.	Dial Backup Options	8-2
Figure 8-2.	Editing Stored Phone Numbers.	8-3
Figure 9-1.	Dial Options Menu	9-1
Figure 10-1.	Status Display.	10-1
Figure 11-1.	Normal Operation Before Initiating Loopback Test . . .	11-1
Figure 11-2.	Initiating a Test.	11-2
Figure 11-3.	Sample Test Status Displays.	11-3
Figure 11-4.	Complete Test Menu	11-4

Figure 11-5. DTE & Loop Test	11-10
Figure 11-6. Initiating a DTE & Loop Test	11-11
Figure 11-7. Loop Only Test	11-12
Figure 11-8. Initiating a Loop Only Test	11-13
Figure 11-9. DTE Only Test Diagram	11-14
Figure 11-10. Initiating a DTE Only Test	11-15
Figure 11-11. DTE with Test Pattern	11-16
Figure 11-12. Initiating a DTE Test with Test Pattern	11-17
Figure 11-13. Test Pattern Only	11-18
Figure 11-14. Initiating a Test Using a Test Pattern	11-19
Figure 11-15. Initiating a Self Test	11-20
Figure 11-16. V.54 RDL with Test Pattern	11-21
Figure 11-17. Initiating a Remote Test	11-22
Figure 11-18. DBU Connection Test	11-23
Figure 11-19. Initiating a DBU Connection Test	11-24
Figure 12-1. Manual Command	12-2
Figure C-1. DSU to Modem Interconnect	C-1
Figure D-1. EIA-232 Connector	D-1

List of Tables

Table 2-1.	Pin Assignments for Line 1 Connector	2-2
Table 2-2.	Pin Assignments for Line 2 Connector	2-3
Table 2-3.	Pin Assignments for Primary EIA-232 Connector	2-4
Table 2-4.	Pin Assignments for Primary V.35 Connector	2-5
Table 2-5.	Pin Assignments for Auxiliary EIA-232 Connector	2-6
Table 5-1.	Network Options AT Commands	5-2
Table 6-1.	DTE Rate Options AT Commands	6-3
Table 6-2.	Data Format Commands	6-5
Table 6-3.	Transmit Clock AT Commands	6-7
Table 6-4.	CS options AT Commands	6-9
Table 6-5.	Short and Long Delays at Different Operating Speeds	6-9
Table 6-6.	Anti-Stream AT Commands	6-11
Table 6-7.	CD Options AT Commands	6-12
Table 6-8.	TR Options AT Commands	6-13
Table 6-9.	SR Options AT Commands	6-14
Table 6-10.	Secondary Rate AT Commands	6-15
Table 7-1.	Test Options AT Commands	7-1
Table 8-1.	AT Commands for Storing Phone Numbers	8-4
Table 8-2.	DBU Options AT Commands for All Models	8-7
Table 8-3.	DBU Options AT Commands for V.32 bis and V.34 Backup.	8-9
Table 11-1.	Messages from the DSU/CSU	11-5
Table 11-2.	Troubleshooting New Installs	11-6
Table 11-3.	Test AT Commands	11-8
Table 11-4.	DTE With Test Pattern Commands	11-9
Table 11-5.	Remote Tests and AT Commands	11-21
Table 12-1.	Manual Commands	12-3
Table A-1.	AT Commands	A-1
Table B-1.	Default Configuration Profiles	B-2

PRODUCT OVERVIEW

The ADTRAN DSU III DBU (dial backup data service unit) provides a reliable, high-speed data connection for customer data terminal equipment (DTE) through digital data service (DDS) lines. The DSU III DBU provides automatic dial backup of the dedicated circuit. There are five backup options available: 4-wire switched 56 (SW56), 2-wire SW56, V.32 bis/42 bis, V.34, and 1B+D ISDN. The DSU III DBU supports both synchronous and asynchronous data communication over the DDS or DBU networks.

The DSU III DBU provides both V.35 and EIA-232 electrical and physical DTE interfaces to accommodate a variety of applications. A second EIA-232 interface is provided if the unit is configured for use on DDS with secondary channel services.

To ensure a reliable connection, the unit features an extended receiver capability which permits operation over long loops (3.4 miles or 5.5 km of 26 AWG at 56 kbps).

The 4-wire SW56 DBU model is compatible with AT&T Accunet and Sprint SW56 type services. The 2-wire SW56 DBU is compatible with DATAPATH type of SW56 services. The V.32 bis/42 bis DBU and the V.34 DBU allow switched backup over the public switched telephone network (PSTN). The 1B+D ISDN model is compatible with National ISDN and supports a U- interface to the Basic Rate ISDN.

Figure 1-1 on page 1-2 shows a typical point-to-point application for the DSU III DBU.

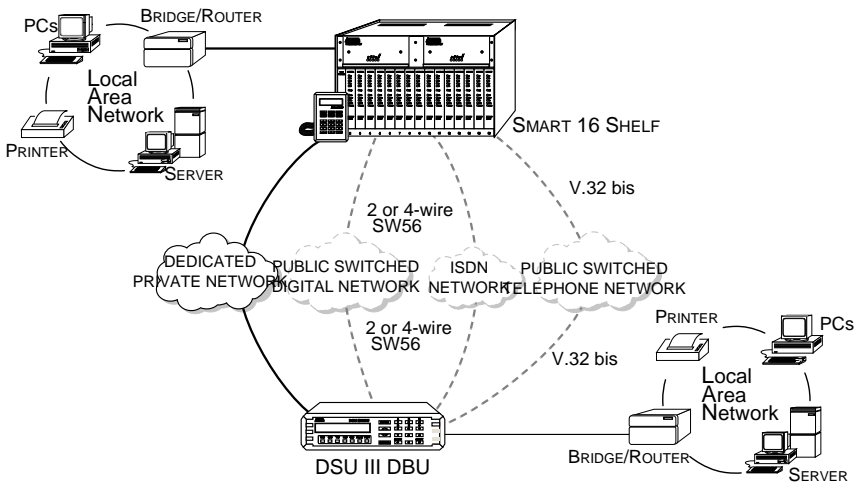

Figure 1-1. Typical Point-to-Point Application for DSU III DBU

DDS OPERATION

DDS is a nationwide service that allows interconnection and transport of data at speeds up to 64 kbps. The local exchange carriers provide the local loop service to DDS customers and may provide data for routing Inter-LATA to an interexchange carrier. In DDS mode, the DSU III DBU supports the 56/64 kbps DDS service rate yielding DTE rates of 2.4, 4.8, 9.6, 19.2, 38.4 (sync or async), 56 kbps, and 64 kbps. An additional rate of 57.6 is available in asynchronous mode. The unit can be configured to run slower DTE rates (async or sync) over the 56 kbps service. Secondary channel operation is supported at all service rates up to 56 kbps, providing terminal rates of 75, 150, 300, 600, 1200, and 2400 bps. The secondary rates available depend on the service rate configured.

DIAL BACKUP OPERATION

There are five backup options available: 4-wire SW56, 2-wire SW56, V.32 bis/42 bis, V.34, and 1B+D ISDN. Contact the local telco provider to determine which services are available.

Dial Backup Options

4-Wire Switched 56 Backup Option

This dial-up 4-wire DDS allows customers to pay for data connection only for the time the unit is active. The regional operating companies provide the 4-wire local loop service to SW56 customers. In SW56 mode, the DSU III DBU supports DTE rates of 2.4, 4.8, 9.6, 19.2, 38.4 (asynchronous or synchronous), and 56 kbps (synchronous). An additional DTE rate of 57.6 kbps is available in async modes.

2-Wire Switched 56 Backup Option

DATAPATH is a switched digital service offered under various service names by the local service provider. The services are generally provided by the Northern Telecom DMS/SL100 family of central office switches. DATAPATH allows the customer to pay for high speed data transfer, up to 56 kbps, only when the unit is active. The dial-up service is delivered via a 2-wire local loop that can be up to 18,000 feet at a signal level of -45 dB.

V.32 bis Backup Option

The V.32 bis/42 bis modem in an asynchronous mode can use V.42 bis data compression to make up for a slower connection rate. V.42 bis increases the effective data throughput from 14.4 kbps to as high as 57.6 kbps, depending on the data type. No compression is supported in synchronous operation. In synchronous applications the maximum speed supported for backup is 14.4 kbps.

V.34 Backup Option

The V.34 modem has all of the V.32 bis modem's modes of operation, plus V.34 and V.FC modes. This allows the V.34 option to run synchronous rates up to 28.8 kbps as opposed to the V.32 at 14.4 kbps. In asynchronous mode the throughput at 57.6 kbps is less dependent on data types.

1B+D Basic Rate ISDN Backup Option

1B+D Basic Rate ISDN service provides the customer with a switched 56/64 kbps circuit. The default data rate for this option is 56K. The 64 kbps data rate may be revised by using the SMART dial string as described in the section *ISDN Dial Backup* on page 8-3. This option provides a U interface to the ISDN network.

Entering Dial Backup Mode

When a condition for entering dial backup mode is detected, the Alarm LED turns on, and the buzzer sounds. The buzzer alternates between 30 seconds on and 30 seconds off unless the DDS line is restored or it is disabled by using the **Quick** key and selecting **TURN OFF BEEP**. See the section *Front Panel* on page 3-4 for more information on the **Quick** key.

Operation During Critical Times

The following four conditions will cause a DSU III DBU to enter dial backup mode:

Loss of Sealing Current

Sealing current is a low voltage DC current provided by the central office (CO) to prevent corrosion over the copper wires used in the local loop. Sealing current may also be used for local loop testing purposes. An absence of sealing current generally is an indication that the loop is open.

Out of Service (OOS) Signal

An OOS signal, generated by the network, indicates a device (or devices) in the network is out of service.

No Receive Signal

This is an indication that the local loop copper pairs may be either open or shorted or the OCU in the CO is inoperative. In a private network this may indicate that the transmitter of the remote DSU is inoperative.

All 1s or all 0s Condition

This condition is usually generated by the network to indicate some device (or devices) in the network is inoperative. Upon detecting an all 1s or all 0s condition, the DSU III DBU initiates a handshake routine to determine whether the remote unit's DTE is the source of the all 1s or 0s condition or if an actual network failure exists.

Operation During Noncritical Times

The DSU III DBU may be configured not to enter dial backup mode if data terminal ready (DTR) is low. This feature prevents the DSU III DBU from entering dial backup during noncritical times such as nights and weekends.

For more information, see the chapter *Configuring Dial Options* on page 8-1.

Conditions for Returning to the DDS Circuit

The DSU III DBU can be configured to automatically revert to the DDS circuit from the dial backup mode or wait to be returned to the DDS manually. Once the DSU III DBU enters dial backup mode, the unit polls the DDS circuit once every 100 ms to determine if the condition causing the DDS circuit failure has been corrected. Once the DSU III DBU determines that the problem has been properly corrected and the DDS circuit is stable, it will wait for the amount of time specified in the restore timer (1 - 255 minutes) before reverting to the DDS circuit. Polling of the DDS circuit is non-intrusive and return to the DDS circuit generally takes 2 - 3 seconds. The backup connection is maintained for one minute after the DDS circuit is restored.

For more information see the chapter *Configuring Dial Options* on page 8-1.

UNPACK, INSPECT, POWER UP

Receipt Inspection

Carefully inspect the DSU III DBU for any shipping damage. If damage is suspected, file a claim immediately with the carrier and contact ADTRAN Customer Service. If possible, keep the original shipping container for use in shipping the DSU III DBU for repair or for verification of damage during shipment.

ADTRAN Shipments Include

The following items are included in ADTRAN shipments of the DSU III DBU:

- DSU III DBU unit
- An 8-position modular to 8-position modular cable
- The user manual
- Appropriate cable for the backup option selected

Customer Provides

The customer must provide an EIA-232 interface cable with standard 25-pin male D-type connectors (Cannon or Cinch DB-19604-432) or a V.35 cable.

Power Up

Each DSU unit is provided with a captive eight-foot power cord, terminated by a three-prong plug which connects to a grounded 115 VAC power receptacle.



Power to the DSU must be provided from a grounded 115 VAC, 60 Hz receptacle.

NETWORK INTERFACE CONNECTION

The DSU III DBU has two eight-position modular jacks labelled Line 1 and Line 2. The line 1 connector is used for connecting to the dedicated (DDS) network. The pinout for the line 1 connector is listed in Table 2-1.

Table 2-1. Pin Assignments for Line 1 Connector

Pin	Name	Description
1	R1	Transmit Data from DSU to Network-Ring 1
2	T1	Transmit Data from DSU to Network-Tip 1
3-6	-	Not Used
7	T	Receive Data from Network to DSU-Tip
8	R	Receive Data from Network to DSU-Ring

The line 2 connector is used for connection to the switched backup network. The pinout for the line 2 connector depends on the model of DBU unit. Pinouts for 4-wire Switched 56, 2-wire Switched 56, V.32 bis, V.34, and 1B+D ISDN DBU options are shown in Table 2-2 on page 2-3.

Table 2-2. Pin Assignments for Line 2 Connector

Pin	Name	Description
4-wire Switched 56		
1	R1	Transmit Data from DSU to Network-Ring 1
2	T1	Transmit Data from DSU to Network-Tip 1
3-6	-	Not Used
7	T	Receive Data from Network to DSU-Tip
8	R	Receive Data from Network to DSU-Ring
2-wire Switched 56, V.32 bis, V.34, and 1B+D ISDN		
1-3	-	Not Used
4	T	Network-Tip
5	R	Network-Ring
6 - 8	-	Not Used

DTE DATA CONNECTION/PRIMARY DTE

The primary DTE should be connected to either the EIA-232 DTE connector or the CCITT V.35 DTE connector. The maximum cable lengths recommended are 50 feet for the EIA-232, and 100 feet for the CCITT V.35. The pin assignments for the connectors are listed in Table 2-3 on page 2-4 and Table 2-4 on page 2-5.

The V.35 connector is recommended for use with data rates above 19.2 kbps. The EIA-232 connector works up to 56 kbps with a low capacitance cable or with the external transmit clock option selected. The primary DTE rate is configured from the front panel. The primary DTE equipment can operate in asynchronous or synchronous modes.



To prevent possible radio frequency interference emissions, a shielded cable is required.

Table 2-3. Pin Assignments for Primary EIA-232 Connector

Pin	EIA	Description
1	AA	Protective Ground (PG)
2	BA	Transmit Data (SD)
3	BB	Receive Data (RD)
4	CA	Request-to-Send (RS)
5	CB	Clear-to-Send (CS)
6	CC	Data Set Ready (SR)
7	AB	Signal Ground (SG)
8	CF	Received Line Signal Detector (CD)
9	-	+12 Test Point
10	-	-12 Test Point
15	DB	Transmit Clock (TC)
17	DD	Receive Clock (RC)
18	-	Local Loopback (LL)
20	CD	Data Terminal Ready (TR)
21	-	Remote Loopback (RL)
22	CE	Ring Indicator (RI)
24	DA	External TX Clock (ETC)
25	-	Test Indicator (TI)

Table 2-4. Pin Assignments for Primary V.35 Connector

Pin	CCITT	Description
A	101	Protective Ground (PG)
B	102	Signal Ground (SG)
C	105	Request to Send (RTS)
D	106	Clear To Send (CTS)
E	107	Data Set Ready
F	109	Received Line Signal Detector (CD)
H	-	Data Terminal Ready (DTR)
J	-	Ring Indicator (RI)
L	-	Local Loopback (LL)
N	-	Remote Loopback (RL)
R	104	Received Data (RD-A)
T	104	Received Data (RD-B)
V	115	Receiver Signal Element Timing (SCR-A)
X	115	Receiver Signal Element Timing (SCR-B)
P	103	Transmitted Data (SD-A)
S	103	Transmitted Data (SD-B)
Y	114	Transmitter Signal Element Timing (SCT-A)
AA	114	Transmitter Signal Element Timing (SCT-B)
U	113	External TX Signal Element (SCX-A)
W	113	External TX Signal Element (SCX-B)
NN	-	Test Indicator (TI)

SECONDARY CHANNEL CONNECTION

If used, the secondary DTE should be connected to the auxiliary EIA-232 connector. The pinout for the connector is shown in Table 2-5.

Table 2-5. Pin Assignments for Auxiliary EIA-232 Connector

Pin	CCITT	Description
1	AA	Protective Ground (PG)
2	BA	Transmit Data (SD)
3	BB	Receive Data (RD)
4	CA	Request to Send (RS)
5	CB	Clear to Send (CS)
6	CC	Data Set Ready (SR)
7	AB	Signal Ground (SG)
8	CF	Carrier Detect (CD) - on all the time

CONFIGURATION

The DSU III contains four different user profiles (sets of configuration options) that are stored in read-only memory. These profiles are listed in the appendix *Default Configuration Profiles* on page B-1. The unit is shipped from the factory with profile 1 (default configuration) loaded into the non-volatile configuration memory. If profile 1 matches the desired system requirements, then no additional configuration is required to put the unit into service. If profile 1 does not match the desired system requirements, modify the default configuration or select another profile more closely matching the desired configuration and modify.

When a new profile is loaded or the existing profile is modified, it is stored in the nonvolatile configuration memory. The DSU III DBU is then configured with that profile every time power is turned on or the unit is reset.

See the chapter *Manual Command* on page 12-1 for information on loading default configuration profiles.

Configuration Methods

The DSU III DBU provides three methods for local configuration and three different methods for remote configuration: AT commands, V.25 commands, and front panel commands.

AT Commands

In addition to the front panel, the DSU III DBU can be configured and controlled with in-band AT commands from an asynchronous DTE port just as modems are.

To exit the data mode and enter the command mode, the asynchronous DTE device must transmit a proper escape sequence of three pluses (+++) to the DSU III DBU. A specified time delay must occur between the last data character and the first escape sequence character. This is the guard time delay, and it can be changed by writing a value to the S12 register. The default value for the guard time is one second. For a valid escape sequence to occur, the DTE must transmit the escape code character three

times in succession with delay between each character being less than the guard time.

Once the command mode is entered, AT commands can be transmitted to the DSU III DBU to configure most of the options or initiate tests to check both the DSU III DBU and the network connections. All command lines must begin with the AT character set in either capital or lower case letters.

The command line may contain a single command or a series of commands after the AT attention code. When a series of commands is used, the individual commands may be separated with spaces for readability. The maximum length for a command line is 40 characters. Each command line is executed by the DSU III DBU upon receipt of a terminating character. The default terminating character is a carriage return (ASCII 013), but it can be changed by writing a different value to register S3.

Before the terminating character is transmitted, the command line can be edited by using the backspace character (ASCII 008) to erase errors so the proper commands can be entered.

Valid AT commands for the DSU III DBU are listed in the appendix *AT Commands* on page A-1.

V.25 bis Commands

When configured for the V.25 bis option, the DSU III DBU accepts in-band dialing and configuration commands from both synchronous and asynchronous DTE ports.

The V.25 bis option supports the following protocols:

- SDLC
- Bi-Sync
- Asynchronous

SDLC Option

Character Format

- Data bits - 8
- Parity bit - Ignored

Command Structure

[F][A][C][v.25 bis COMMAND][FCS][F]

The address field [A] is FFH. The control field [C] is set to 13H except for cases of multi-frame responses. For this case, the control field is set to 03H in all but the last frame. The 03H in the control field indicates that other frames are to follow while the 13H in the control field indicates the final frame.

Bi-Sync Option

Character Format

- Data bits - 7
- Parity bit - Odd

Command Structure

[SYN][SYN][STX][v.25 bis COMMAND][ETX]

Asynchronous Option

Character Format

- Start bit- 1
- Data bits- 7
- Parity bit- Even
- Stop bit- 1

Command Structure

[v.25 bis COMMAND][CR][LF]

Command Descriptions

The ADTRAN V.25 bis command set is a subset of the CCITT V.25 bis command set. In addition to the CCITT commands supported, ADTRAN has added configuration commands for both local and remote DSUs. The ADTRAN V.25 bis command set follows:

CNL Configuration local
CNR Configuration remote

Possible responses to V.25 bis commands follows:

VALA Valid V.25 command processed
INV An invalid command detected
INVCU Unknown command detected
INVPS Invalid parameter syntax
INVPV Invalid parameter value
INVBL Invalid local password
INVBM Invalid remote password

If verbose responses are disabled (ATV0), the following three-character responses are the only ones returned:

VAL Valid V.25 command processed
INV Invalid command received

Syntax and Possible Responses

CNL (Configuration Local)

This command is used to pass AT commands to the local DSU via the V.25 bis command processor. This allows the DSU III DBU to be configured with AT commands using a synchronous interface. The format is as follows:

```
CNL[LOCAL PASSWORD];AT[ONE OR MORE AT COMMANDS]
```

A local password may not be required depending on the present configuration of the unit. Responses to CNL commands are returned in the data format currently configured. Possible responses include: VALA and INVAn.

CNR (Configuration Remote)

This command is used to pass AT commands over the network to the remote DSU via the V.25 bis command processor. This allows a remote DSU III DBU to be configured from a synchronous interface. The format of this command follows:

```
CNR[REMOTE PASSWORD];AT[ONE OR MORE AT COMMANDS]
```

The remote password may or may not be required depending on the present configuration of the remote unit. Responses to the CNR commands are returned in the data format currently configured. Possible responses include: VAL and INVAn.

Remote Command

The DSU III DBU can be controlled remotely from another DSU III DBU. The Configuration (CONFIG) menu allows the DSU III DBU remote configuration capability to be enabled or disabled. For more information, see the chapter *Configuration Overview* on page 4-1.

Chapter 3 Operation

MENU STRUCTURE

The DSU III DBU uses a multilevel menu approach to access its many features. All menu operations are displayed in the LCD window.

The opening menu is the access point to all other operations. Each **MAIN** menu item has several functions and submenus to identify and access specific parameters.

LCD display of the **MAIN** menu:

1=STATUS	2=TEST
3=CONFIG	4=DIAL

Main Menu

There are four branches of the **MAIN** menu: **STATUS**, **TEST**, **CONFIGURATION** (**CONFIG**), and **DIAL**.

Status

STATUS is used to display all relevant information for the network and DTE interfaces. It displays the current operating data mode, loop status, DTE data rate and format, and DTE interface lead status. The system returns to the status display when idle.

Test

TEST is used to control local and remote testing. Select local or remote testing, and the type of test and test pattern when required.

Configuration (CONFIG)

CONFIGURATION is used to select network and DTE operating parameters. When certain loop rates (56 or 64 kbps) are selected, a scramble option sub-menu is displayed instead of the DTE Rate menu to control scrambling.

Dial

DIAL provides manual dialing functions. Key in a number to dial or select one of the ten stored numbers.

Basic Menu Navigation

Four function keys on the left side of the DSU III DBU keypad allow the various menu branches to be entered, exited, and scrolled through. The four function keys are defined below:

Enter	Selects a displayed item.
Up Arrow	Scrolls up a menu tree.
Down Arrow	Scrolls down a menu tree.
Cancel	Exits (back one level) from the current branch of the menu.

To choose a menu item, press the corresponding number or alpha character on the keypad (press **Shift** to activate menu items with alpha selections). The item flashes on and off to show it is the currently selected (active) choice. Pressing either the up or down arrows scrolls through the available menu items. Press **Enter** to select the item.

The following example and Figure 3-1 illustrate how to select the DSU III DBU loop rate options:

1. Select **CONFIGURATION** (CONFIG) by pressing **3** and then pressing **Enter**.
2. Select **LOCAL** or **REMOTE** configuration by pressing the corresponding number and then pressing **Enter**.
3. Use the up and down arrows to view submenu items.
4. Choose an item on the submenu such as **NETWORK OPTIONS** (NETWORK OPT).
5. To select **NETWORK OPT** press **1** and then press **Enter**.
6. To select **LOOP RATE** options, press **1** and then press **Enter**.

3=CONFIG	1=LOCAL	1=NETWORK OPT.	1=LOOP RATE
	2=REMOTE	2=DTE OPTIONS	2=-NETWORK ADDR.
		3=TEST OPTIONS	3=REMOTE CONFIG
		4=DIAL OPTIONS	4=CLOCK SOURCE
		5=MANUAL COMMAND	

Figure 3-1. Example of Basic Menu Navigation

FRONT PANEL

The DSU III DBU faceplate is shown in Figure 3-2.

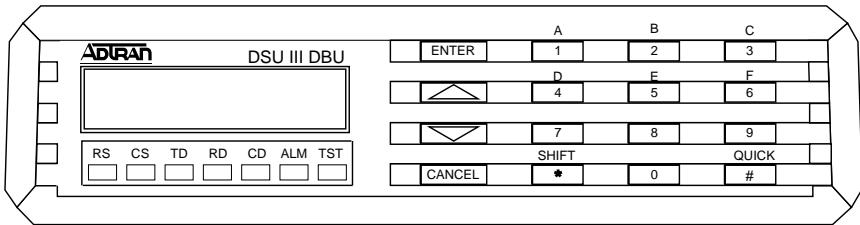

Figure 3-2. DSU III DBU Front View

The following function descriptions apply to both the stand-alone unit and the rackmount unit when using the DATAMATE modules.

LCD Window

The LCD window displays menu items and messages in 2 lines by 16 characters.

Enter

Enter selects active menu items. To activate a menu item, press the number of the item. When the menu item is flashing (active), press **Enter** to select it. A submenu item is invoked or a configuration parameter is set. The display of `Command Accepted` indicates a valid operation.

Numeric Keypad

The numeric keypad contains the numbers **0** through **9** and alpha characters **A** through **F**, which are used to activate menu items. Numbers **0** through **9** are also used to enter parameters.

Shift

Alpha characters are entered by pressing **Shift** before each desired character.

To activate a menu item designated by an alpha character rather than a number, display the menu item using the up and down arrows; press and release **Shift**, then press the letter. Press **Enter** to select the item.

If a key is pressed without using **Shift**, the numbered item becomes active instead of the alpha item. If this happens, repeat the correct procedure.

Quick

The **Quick** key used during most operations returns immediately to the **MAIN** menu. During a test, the **Quick** key displays the Exit Test screen. During dial backup, **Quick** displays a menu with options to **HANG UP** or **STAY ON THE LINE**.

Cancel

Cancel stops the current activity and returns to the previous menu. Repeat until the desired menu level is reached. When a submenu item is displayed, press **Cancel** to exit the current display and return to the previous menu. Repeat as necessary.

Up and Down Arrows

Up and down arrows scroll through the submenu items available in the current menu. Submenu items appear two at a time in a circular or wrapping fashion. When the submenu items are scrolled, they continuously appear from beginning to end in a forward (down arrow) or reverse (up arrow) pattern.

LED Description

The DSU III DBU has seven LED indicators: RS, CS, TD, RD, CD, ALM, and TST. These LEDs are identified as follows:

RS: Request to Send	Reflects the status of the request to send pin of the EIA-232 connector.
CS: Clear to Send	Reflects the status of the clear to send pin of the EIA-232 connector.
TD: Transmit Data	This LED is active when data is transmitted from the DTE.
RD: Receive Data	This LED is active when data is received from the network.
CD: Carrier Detect	This LED is active when frame synchronization is achieved and the DSU III DBU is ready to transfer data.
ALM: Alarm Indication	This LED activates whenever an alarm condition exists. Alarm conditions include: <ul style="list-style-type: none">• Open loop on network• No frame synchronization• Unit in dial backup• Problem on dial backup line
TST: Test Mode	This LED is on whenever the unit is in test mode.

REAR PANEL

The rear panel contains three DTE connectors which provide primary channel V.35 or EIA-232, and a secondary channel EIA-232 port (auxiliary EIA-232). An 8-pin telco jack, a captive power cord, and a power switch are also located on the rear panel. Pin assignments for the DTE and network connections are listed in the chapter *Installation* on page 2-1. The DSU III DBU rear panel is shown in Figure 3-3 on page 3-7.

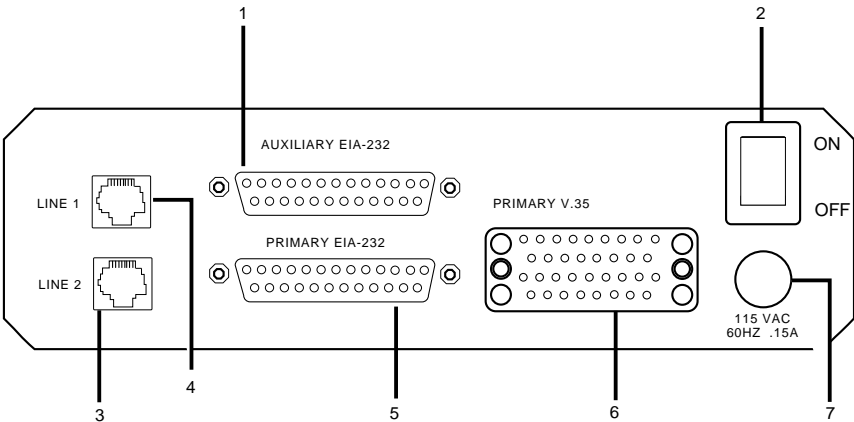

Identification of Numbers

Item	Function
1. Auxiliary EIA-232	Secondary channel services
2. Power Switch	Used to turn power on or off
3. Line 1	Connection to the dedicated circuit
4. Line 2	Connection to dial backup
5. Primary EIA-232	DTE interface
6. Primary V.35	High speed DTE interface
7. 115 VAC Connection	Power cord connection

Figure 3-3. DSU III DBU Rear View

Chapter 4 Configuration Overview

LOCAL AND REMOTE CONFIGURATION

The DSU III DBU can be configured locally using the front panel, or communications can be established with a remote DSU so the front panel of the local DSU can be used to configure the remote DSU. During remote configuration the DSU III DBU prompts for the remote address before displaying the **CONFIGURATION** menus.

The **CONFIGURATION** menu consists of a group of five submenus relating to a specific interface or function of the DSU III DBU that requires setup:

1=Network Opt.	Network Interface Parameters
2=DTE Options	DTE Interface Parameters
3=Test Options	Unit Test Options
4=Dial Options	Unit Dialing Options
5=Manual Command	ADTRAN Specific Commands

The DSU III DBU contains four different user profiles (sets of configuration options) stored in read only memory; see the appendix *Default Configuration Profiles* on page B-1. The unit is shipped from the factory with profile number 1 (default configuration) loaded into the current (nonvolatile configuration) memory. If profile 1 matches requirements for the system, then no additional configuration is required to put the unit into service. If profile 1 does not match system requirements it can be modified, or one of the other profiles that more closely matches the system requirements can be loaded into current memory. When a different profile is loaded, or the existing profile is modified, it is stored in the current (nonvolatile configuration) memory. The DSU III DBU is then configured with that profile every time power is turned on or until the unit is reset.

For detailed information on configuration see the chapters *Configuring Network Options* on page 5-1, *Configuring DTE Options* on page 6-1, *Configuring Test Options* on page 7-1, *Configuring Dial Options* on page 8-1, and *Manual Command* on page 12-1.

A complete **CONFIGURATION** menu is shown on the enclosed insert.

Chapter 5 **Configuring Network Options**

NETWORK OPTIONS

The **NETWORK OPTIONS** configuration parameters control the loop operation of the DSU III DBU.

Once a parameter is set, `Command Accepted` is displayed briefly before returning to the active menu.

Table 5-1. Network Options AT Commands

Front Panel	AT Command
Loop Rate Commands	
AUTO no secondary channel	%B0
2.4K no secondary channel	%B1
4.8K no secondary channel	%B2
9.6K no secondary channel	%B3
19.2K no secondary channel	%B4
38.4K no secondary channel	%B5
56K no secondary channel	%B6
64K clear channel	%B7
2.4K with secondary channel	%B9
4.8K with secondary channel	%B10
9.6K with secondary channel	%B11
19.2K with secondary channel	%B12
38.4K with secondary channel	%B13
56K with secondary channel	%B14
Network Address	
XX (decimal)	_N=xx
Remote Configuration	
Disabled	&P4
Enabled	&P5
Clock Source	
Master	_X0
From Network	_X1

Loop Rate

The **LOOP RATE** option sets the loop operating speed. The unit should be set to the rate required by the DDS Service. The DSU III DBU also supports subrate DTE data over a 56 kbps loop. The loop rate must be set independently of the DTE rate.

Eight loop rate selections are available (shown in Figure 5-1). After selecting any loop rate other than Auto or 64 kbps the option for a secondary channel is available. The secondary channel rate is determined by the current loop rate.



The DSU III DBU does not support subrates operating over a 64 kbps loop rate.

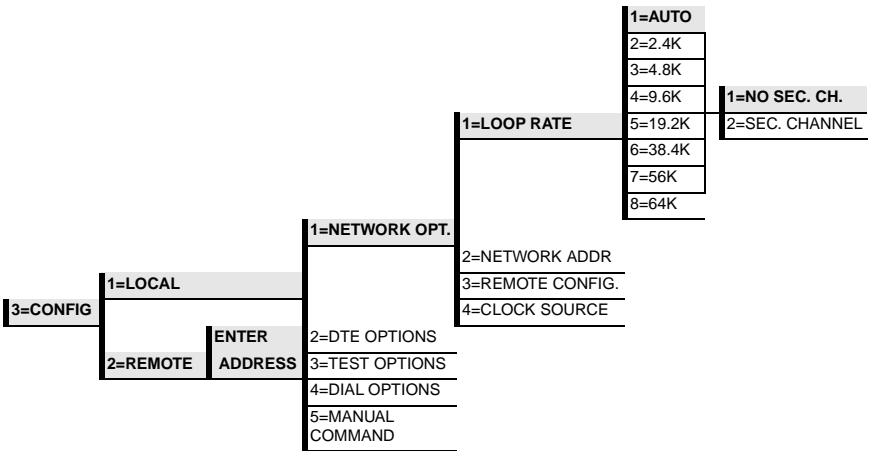

Figure 5-1. Setting Loop Rate Options

The default factory setting is **AUTO**, with no secondary channel. The various loop rates and format selections are listed in Table 5-1 on page 5-2 with the equivalent AT commands that perform the same configuration functions.

Network Address

A two-digit decimal address can be assigned to each DSU III DBU. This addressing capability makes it possible to perform remote configuration and testing in point-to-point and multi-drop networks. Figure 5-2 shows the menu path used to change the network address. The factory default setting is 0.

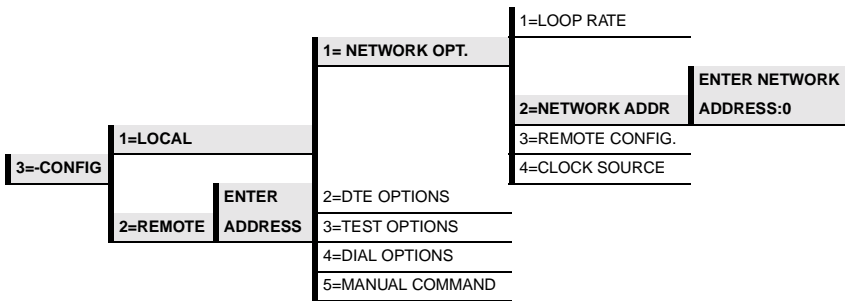

Figure 5-2. Setting the Network Address

Remote Configuration

This option sets up the DSU III DBU to accept or reject remote configuration commands. Figure 5-3 on page 5-5 shows the menu path for enabling/disabling remote configuration. The factory default setting is **ENABLED**.

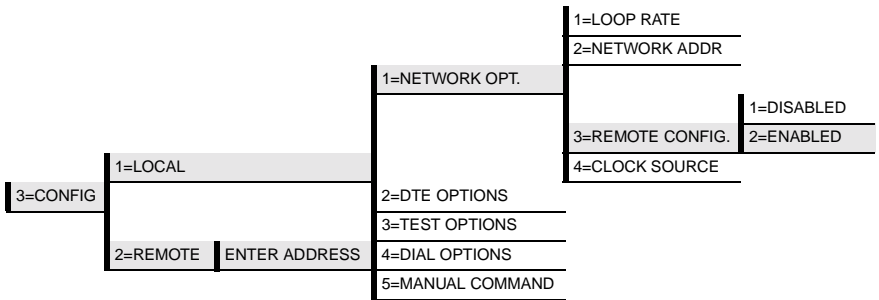

Figure 5-3. Remote Configuration

Clock Source

The **CLOCK SOURCE** options specify the timing source for the DSU III DBU's internal circuitry. The factory default setting is **FROM NETWORK** (see Figure 5-4).

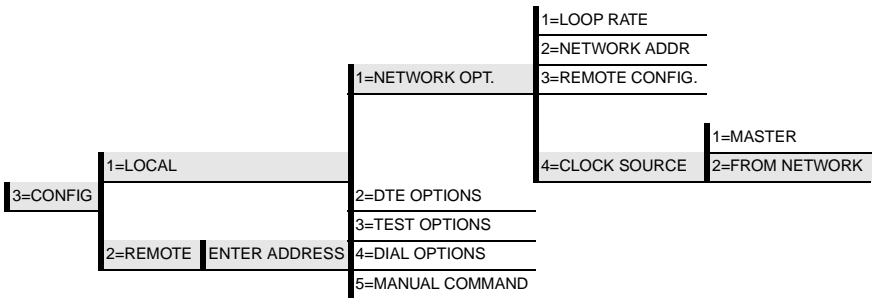

Figure 5-4. Setting the Clock Source

When operating on a DDS network, the timing should be **FROM NETWORK**. On a point-to-point private network, one DSU III DBU must be set for **MASTER**, the others set for **FROM NETWORK**.

Chapter 6 Configuring DTE Options

DTE OPTIONS

The DTE Options menu is used to select the configuration parameters that control the operation of the DTE Interface of the DSU III DBU.

DTE Rate

The DSU III DBU supports six DTE rates over a 56 kbps circuit with no secondary channel and seven DTE rates over a 64 kbps circuit. If a DTE rate higher than the current loop rate is selected, the DTE rate automatically sets to match the slower loop rate; the DSU III DBU briefly displays `DTE RATE SAME AS THE NETWORK` before returning to the status screen. The factory default setting is **SAME AS LOOP**.

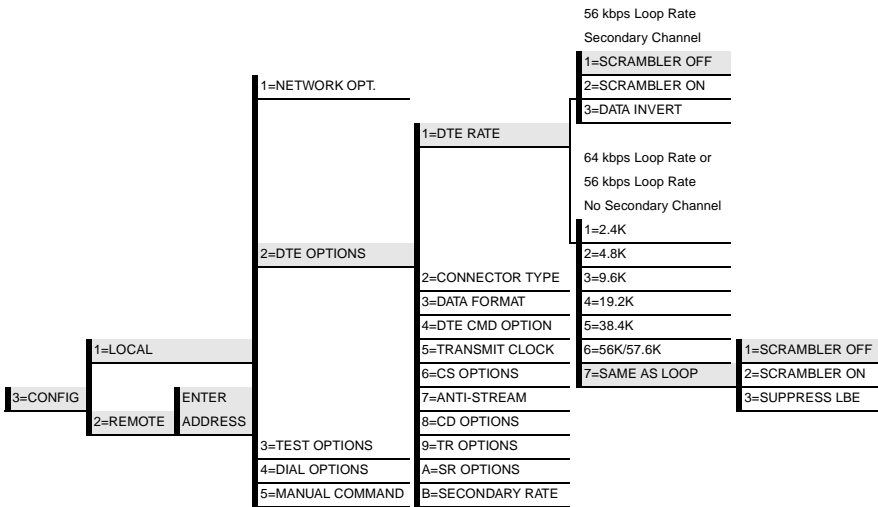

Figure 6-1. Selecting DTE Rates

The AT commands for setting the DTE rate options are shown in Table 6-1 on page 6-3.

Table 6-1. DTE Rate Options AT Commands

Front Panel	AT Command	Description
1=2.4K	%K3	DTE rate: 2.4K sync and async
2=4.8K	%K4	DTE rate: 4.8K sync and async
3=9.6K	%K5	DTE rate: 9.6K sync and async
4=19.2K	%K6	DTE rate: 19.2K sync and async
5=38.4K	%K7	DTE rate: 38.4K sync and async
6=56K/57.6K	%K8	DTE rate: 56K sync or 57.6K async
7=SAME AS LOOP	%K9	DTE rate matches loop rate
1=SCRAMBLER OFF	_F0	DTE data scrambler disabled
2=SCRAMBLER ON	_F1	DTE data scrambler enabled
3=DATA INVERT	_F2	DTE data invert enabled (56 kbps secondary channel loop rate only)
3=SUPPRESS LBE	_F2	Suppresses loopback enable code (LBE) in transmit data from the DTE after 30 bytes in a row detected (64 kbps loop rate only)

If the DSU III DBU is set for a loop rate of 56 kbps secondary channel or 64 kbps then scrambler on/off options are available. The factory default setting is **SCRAMBLER OFF**.



*For point-to-point operation at 56 kbps with secondary channel, the network requires that the primary and secondary channel data not be all zeros simultaneously. For HDLC protocol applications, this constraint can be eliminated by selecting either the **DATA INVERT** option or the **SCRAMBLER ON** option.*

*For 64 kbps clear channel operation, there is a possibility the DTE data sequences might mimic network loop maintenance functions and erroneously cause other network elements to activate loopbacks. To prevent this, the **SCRAMBLER ON** option should be selected for both the local and remote DSU III DBU.*

Connector Type

The **CONNECTOR TYPE** option is used to specify which of the primary channel connectors is used to connect to the DTE. Figure 6-2 shows the menu path used to set the connector type. The factory default setting is V.35. There are no AT commands available to set the connector type.

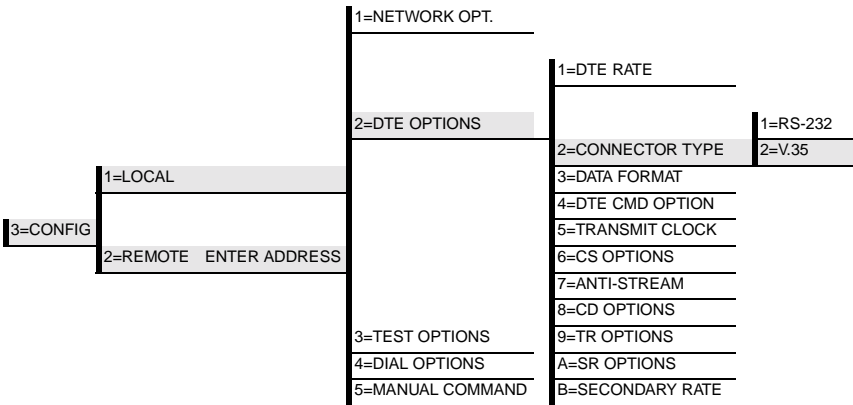

Figure 6-2. Selecting the Connector Type

Data Format

The **DATA FORMAT** option is used to select either the synchronous or asynchronous mode of operation for the DTE interface. The factory default setting is **SYNCHRONOUS** (see Figure 6-3). If **ASYNCHRONOUS** is chosen, the length of the data bytes must be selected.

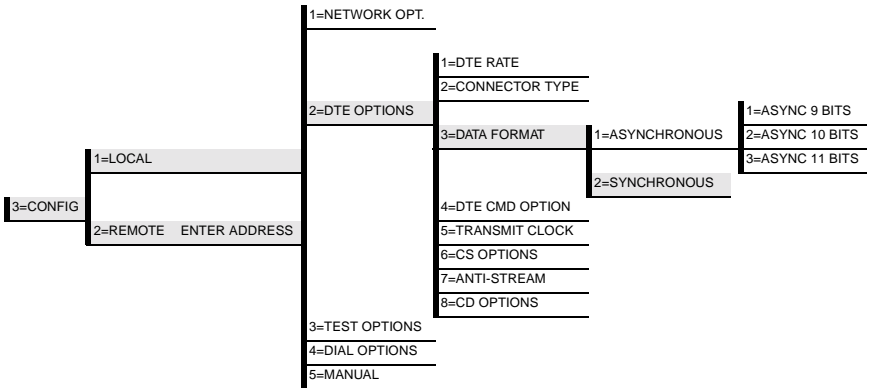

Figure 6-3. Selecting Asynchronous or Synchronous Data Format

Table 6-2 shows the AT commands that can be used to set the **DATA FORMAT** to **ASYNCHRONOUS** or **SYNCHRONOUS**.

Table 6-2. Data Format Commands

Front Panel	AT Command	Front Panel
1=ASYNCHRONOUS	&Q0	1=ASYNCHRONOUS
2=SYNCHRONOUS	&Q2	2=SYNCHRONOUS
For asynchronous options, select the length of the data bytes.		
1=ASYNC 9 BITS	N/A	1=ASYNC 9 BITS
2=ASYNC 10 BITS	N/A	2=ASYNC 10 BITS
3=ASYNC 11 BITS	N/A	3=ASYNC 11 BITS

DTE Command Option

The **DTE COMMAND** option is used to enable AT commands from the DTE, enable V.25 bis (SDLC) commands, enable V.25 (Bisync and Async), or disable all DTE command modes (see Figure 6-4).

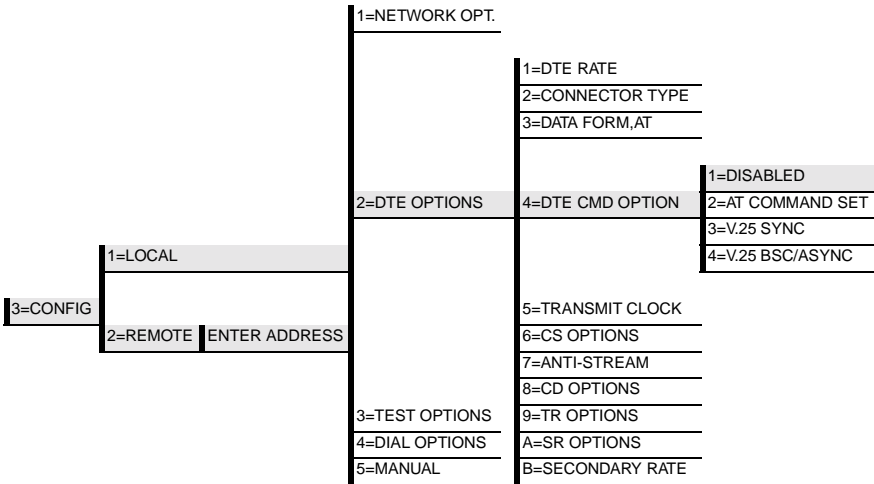

Figure 6-4. Selecting DTE Command Option

Transmit Clock

The **TRANSMIT CLOCK** option is used to select the source of the clock used to transfer data from the DTE into the DSU III DBU. Figure 6-5 shows the menu path used to set the **TRANSMIT CLOCK** option.

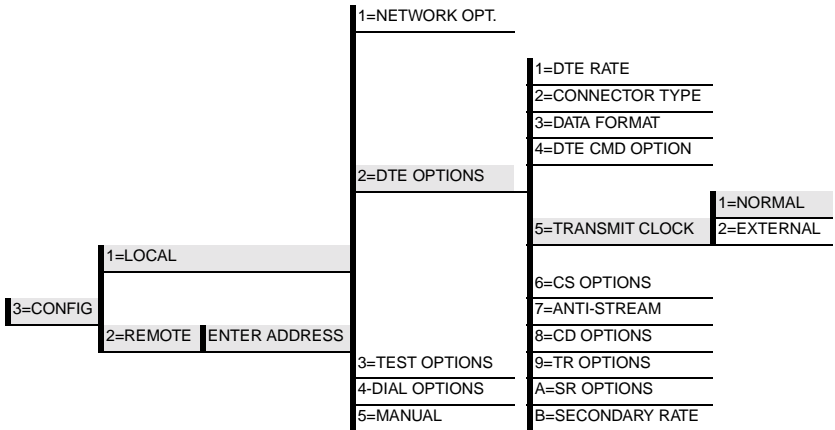

Figure 6-5. Transmit Clock Options

Table 6-3 shows the AT commands used to set the **TRANSMIT CLOCK** options.

Table 6-3. Transmit Clock AT Commands

Front Panel	AT Command	Description
1=NORMAL	&X0	TX clock from DSU selected
2=EXTERNAL	&X1	ETC clock from DTE selected

The **EXTERNAL** clock option is normally used in modem tail circuit applications. A DSU to modem interconnect diagram for this application is shown in the appendix *DSU to Modem Interconnect* on page C-1.

The **EXTERNAL** clock option is also recommended when the EIA-232 connector is used for 56 kbps and 64 kbps applications. A special DSU cable diagram for this application is shown in the appendix *EIA-232 Connector* on page D-1. Using this option and special cable eliminates data errors caused by excessive delays in the DTE transmit clock receiver and transmit data driver.

Clear to Send (CS) Options

The **CS OPTIONS** menu is used to select the control mode for the CS lead. Figure 6-6 shows the menu path used to access the **CS OPTIONS** menu. The default factory setting is **FOLLOWS RS** with **CS DELAY SHORT**.

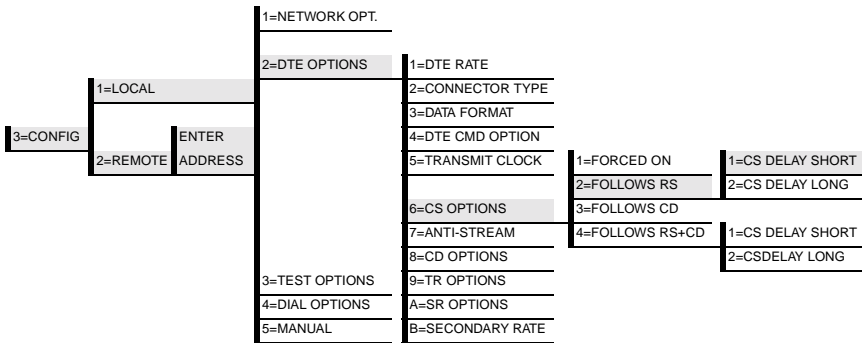

Figure 6-6. Selecting CS Options

If one of the options chosen involves request to send (RS), then the delay from RS to CS must be selected. Table 6-4 on page 6-9 shows the AT Commands used to set the CS options.

Table 6-4. CS options AT Commands

Front Panel	AT Cmd.	Description
1=FORCED ON	&R0	CS always on
2=FOLLOWS RS	&R1	CS state same as RS state
3=FOLLOWS CD	&R2	CS state same as CD state
4=FOLLOWS RS+CD	&R3	CS state same as RS and CD state
For Follows RS options, select the length of the delay.		
1=CS DELAY SHORT	_D0	Short delay from RS to CS selected
2=CS DELAY LONG	_D1	Long delay from RS to CS selected

Specified times for the short and long delays at the different operating speeds are shown in Table 6-5.

Table 6-5. Short and Long Delays at Different Operating Speeds

Rate	Short Delay	Long Delay
64	1.1ms	16.1ms
56	1.1ms	16.1ms
19.2	1.5ms	16.5ms
4.8	1.5ms	16.5ms
2.4	1.5ms	16.5ms

Anti-Stream

The **ANTI-STREAM** option is used to select the anti-stream timeout. Figure 6-7 shows the menu path used to access the **ANTI-STREAM** options menu. The anti-stream timeout is the maximum time the DSU III DBU transmits data into the network from the DTE. This feature prevents one DTE device on a multi-drop network from continuously tying up the transmit circuit back to the master DSU.

The anti-stream timer is reset to zero when RS changes to the active state and is updated every second while RS is active. When the anti-stream timeout expires, the DSU III DBU stops transmitting DTE data into the network but continues to accept data from it. This condition exists until the DTE deactivates the RS input.

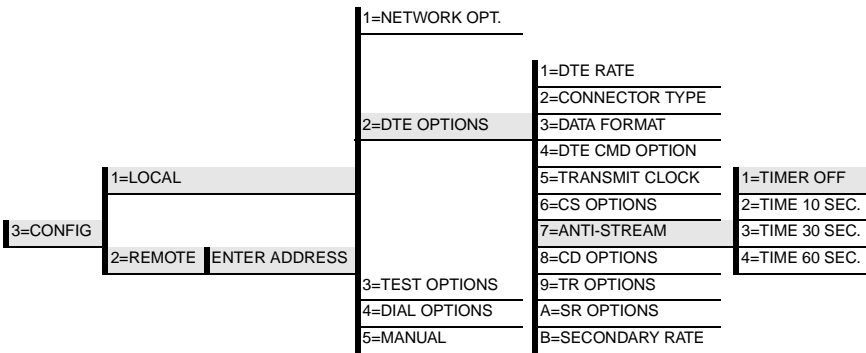

Figure 6-7. Anti-Stream Options

The factory default setting is **TIMER OFF**. Table 6-6 on page 6-11 shows the available options and their AT commands.

Table 6-6. Anti-StreamAT Commands

Front Panel	AT Command	Description
1=Timer Off	%T0	Anti-stream timer disabled
2=Time 10 Sec.	%T1	Timeout equals 10 seconds
3=Time 30 Sec.	%T2	Timeout equals 30 seconds
4=Time 60 Sec.	%T3	Timeout equals 60 seconds

CD Options

The **CD OPTIONS** menu is used to select the control mode for the receive line signal detector (CD) lead. The default factory setting is **NORMAL**; see Figure 6-8.

**Figure 6-8. Selecting CD Options**

Table 6-7 on page 6-12 shows the equivalent AT commands for setting CD options.

Table 6-7. CD Options AT Commands

Front Panel	AT Command	Description
1=FORCED ON	&C0	On all the time
2=NORMAL	&C1	On only when data present on loop

Data Terminal Ready (TR) Options

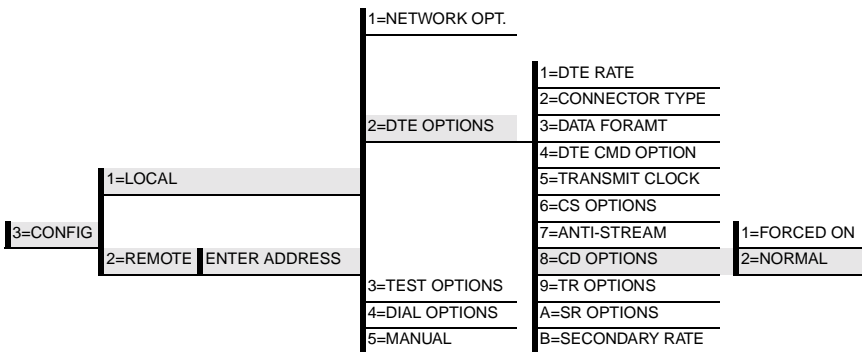
The **TR OPTIONS** menu is used to select the DSU III DBU response to the data terminal ready (TR) lead. The factory default setting is **IGNORED**; see Figure 6-9.

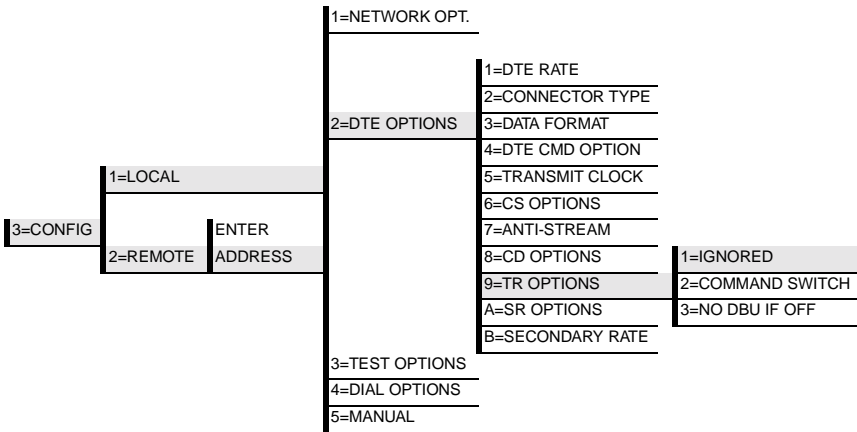

Figure 6-9. Selecting Data Terminal Ready (TR) Options

Table 6-8 on page 6-13 shows the equivalent AT commands for setting TR options.

Table 6-8. TR Options AT Commands

Front Panel	AT Command	Description
1=IGNORE	&D0	Ignore the TR input
2=COMMAND SWITCH	&D2	Switch to command state if TR is off
3=NO DBU IF OFF	&D3	No dial backup if TR is off

Data Set Ready (SR) Options

The **SR OPTIONS** menu is used to select the operating mode for the data set ready (SR) lead. Use **Shift + A** to activate the **SR OPTIONS** submenu; press **Enter** to enter the **SR OPTIONS** submenu. The factory default setting is **OFF TEST ONLY** (shown in Figure 6-10).

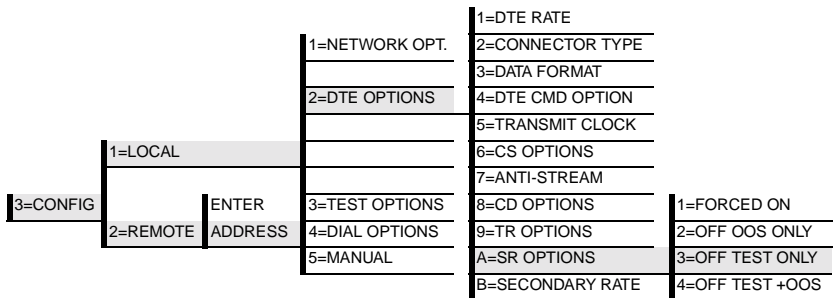

Figure 6-10. Setting Data Set Ready (SR) Options

Table 6-9 on page 6-14 shows the AT commands for setting SR options.

Table 6-9. SR Options AT Commands

Front Panel	AT Command	Description
1=FORCED ON	&S0_C1	Always on
2=OFF OOS ONLY	&S1_C1	Off when network out of service
3=OFF TEST ONLY	&S0_C0	Off for test only
4=OFF TEST+OOS	&S1_C0	Off for test and OOS

Secondary Rate

The **SECONDARY RATE** option is used to select the operating speed for the secondary channel if the secondary channel option was selected during setup of the **NETWORK OPTIONS**. See Figure 6-11.

Use **Shift + B** to activate the secondary rate submenu. The factory default is **OFF**.

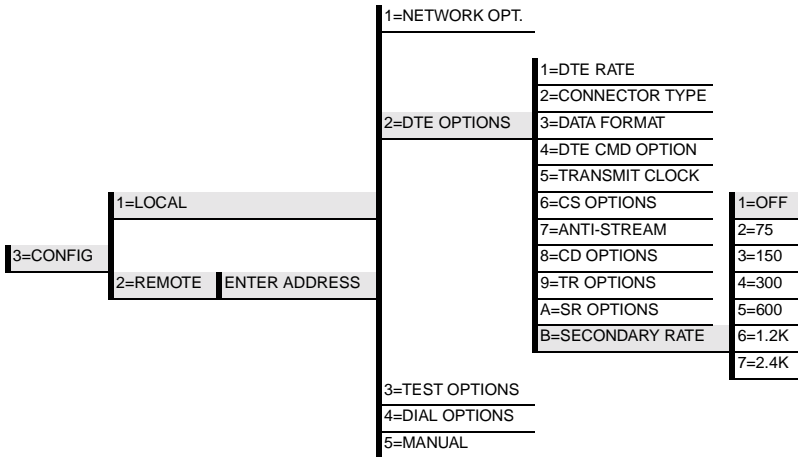

Figure 6-11. Setting the Secondary Rate

Table 6-10 shows the equivalent AT commands for setting the secondary rate option.

Table 6-10. Secondary Rate AT Commands

Front Panel	AT Command	Description
1=OFF	_Y0	No secondary channel selected
2=75	_Y1	Secondary channel rate: 75 bps
3=150	_Y2	Secondary channel rate: 150 bps
4=300	_Y3	Secondary channel rate: 300 bps
5=600	_Y4	Secondary channel rate: 600 bps
6=1.2K	_Y5	Secondary channel rate: 1200 bps
7=2.4K	_Y6	Secondary channel rate: 2400 bps

Chapter 7 **Configuring Test Options**

TEST OPTIONS

The **TEST OPTIONS** menu enables or disables different test modes and specifies the maximum test time allowed. Table 7-1 shows the AT commands for setting the Test options.

Table 7-1. Test Options AT Commands

Front Panel	AT Command	Description
Enter Timeout	S18=x	Specify 0 - 255 second test timeout
RDL Ignored	&T5	RDL request from remote DSU ignored
RDL Accepted	&T4	RDL request accepted
EIA LLB Disabled	_A0	Responds to local loopback
EIA LLB Enabled	_A1	No response to local loopback
EIA RLB Disabled	_R0	No response to remote loopback
EIA RLB Enabled	_R1	Responds to remote loopback

Test Timeout

The **TEST TIMEOUT** option sets the length of time a DSU III DBU remains in a test mode before automatically returning to the data mode. Enter the timeout in two-digit decimal value. The factory default setting is off (**0**). Figure 7-1 shows the menu path used to access **TEST TIMEOUT**.

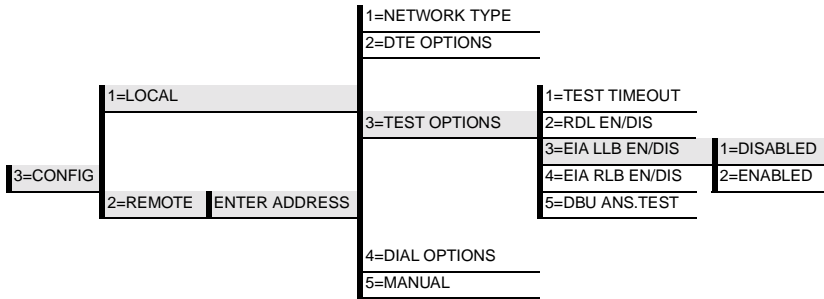

Figure 7-1. Setting Test Timeout Option

Remote Digital Loopback (RDL)

The RDL option specifies whether or not the DSU III DBU responds to an RDL request from the far end of the circuit. The factory default setting is **RDL ACCEPTED**. Figure 7-2 shows the menu path for the RDL option.

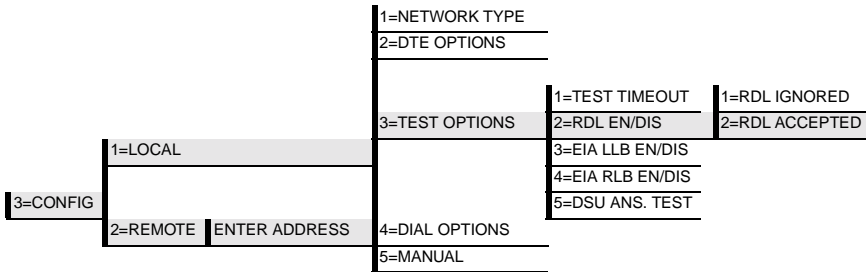

Figure 7-2. Remote Digital Loopback

EIA LLB

The **EIA LLB** (Electronics Industries Association local loopback) option specifies whether or not the DSU III DBU responds to the local loopback input from the DTE. The factory default setting is **DISABLED**. Figure 7-3 shows the menu path used to access the **EIA LLB** option.

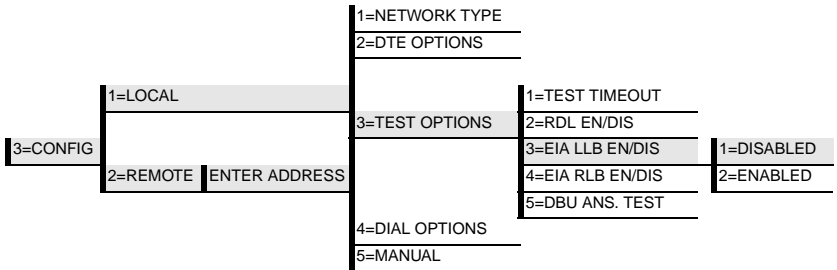

Figure 7-3. EIA Local Loopback Options

EIA RLB

The **EIA RLB** (remote loopback) option specifies whether or not the DSU III DBU responds to the RLB input from the DTE. The factory default setting is **DISABLED**. Figure 7-4 shows the menu path for the **EIA RLB** options.

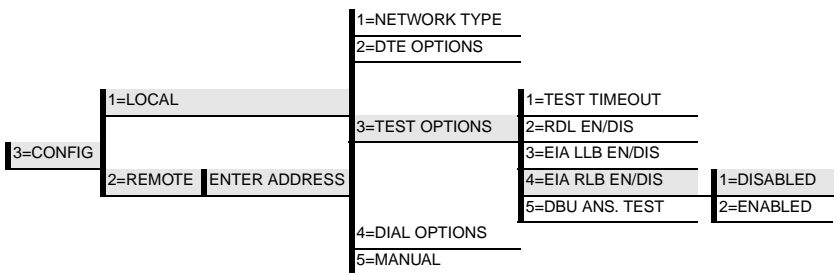

Figure 7-4. EIA Remote Loopback Options

DBU Answer Test

The dial backup connection can be tested while data is passing on the DDS. In order for this test to be performed, **DBU ANSWER TEST** must be enabled on the remote unit. If **DBU ANSWER TEST** is not enabled, the remote unit will not accept a DBU test from the other end.

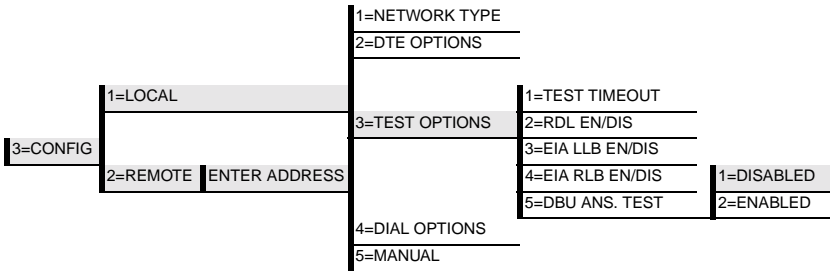

Figure 7-5. DBU Answer Test Option

Chapter 8 **Configuring Dial Options**

DIAL OPTIONS

The **DIAL OPTIONS** menu stores up to ten phone numbers, defines the dial backup operation when the DDS circuit fails, and programs the passcode security feature of the DSU III DBU.

Figure 8-1 on page 8-2 shows the full **DIAL BACKUP OPTIONS** (4=Dial Options) menu. Shaded items are restricted to the specified DBU version.

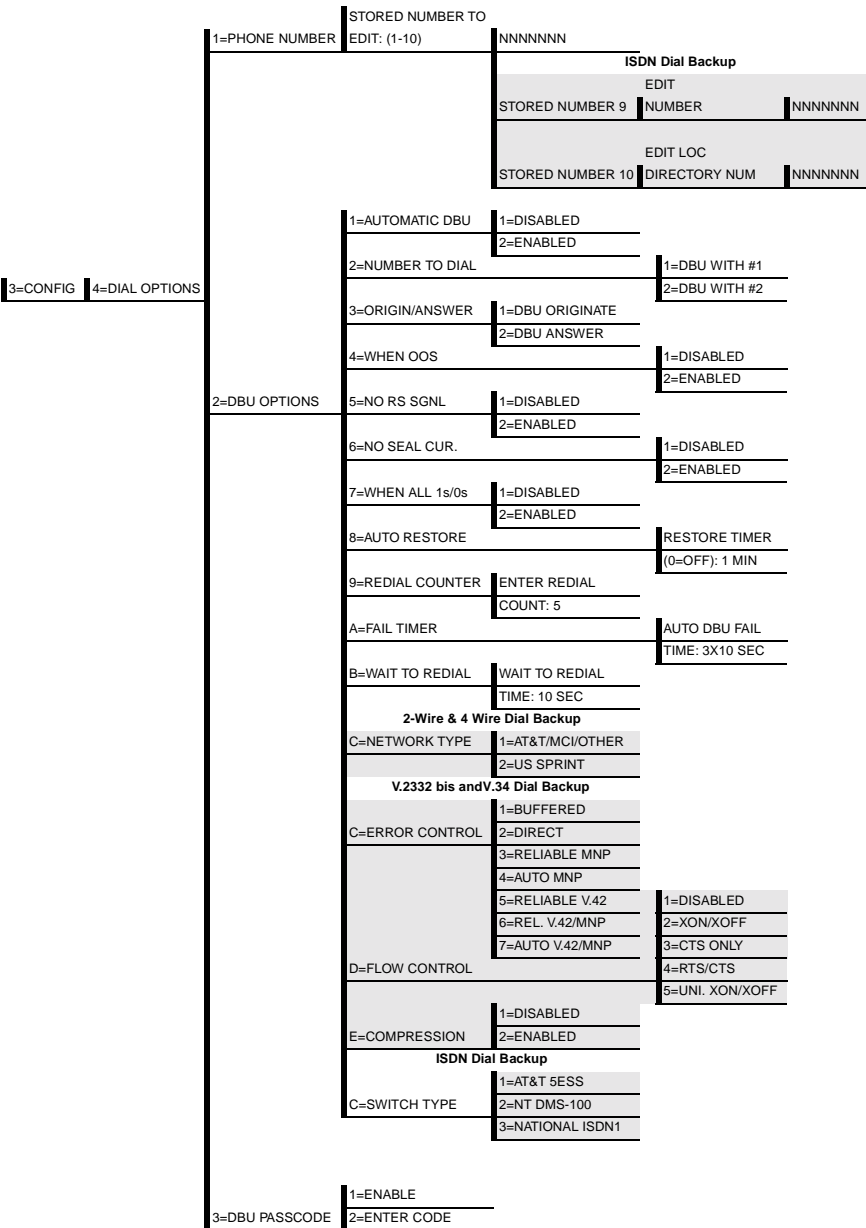

Figure 8-1. Dial Backup Options

Phone Number

The DSU III DBU stores up to ten numbers of 36 digits each. Edit a phone number by reentering the entire number. This process overwrites the previously stored number. Figure 8-2 shows the menu path used to access the **PHONE NUMBER** option.

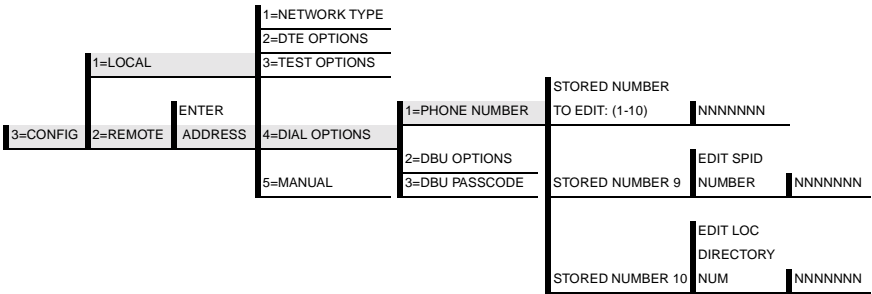

Figure 8-2. Editing Stored Phone Numbers

ISDN Dial Backup

Table 8-1 on page 8-4 shows the AT Commands available for the **PHONE NUMBER** options.

If a clear channel 64 kbps circuit is required to back up the DDS circuit, placing a #4 at the end of the SMART dial string (phone number entered into stored number 1-8) establishes the backup connection at 64 kbps instead of 56 kbps. For example: 2059718000#4.

Setting the Service Profile Identifier (SPID)

For ISDN dial backup, the service profile identifier (SPID) is stored in **STORED NUMBER 9**. The SPID is a sequence of digits identifying ISDN terminal equipment to the ISDN switch when more than one ISDN set has been attached to the same central office line. The SPID is assigned by the telco when the ISDN line is installed and normally resembles the phone number.

Only the AT&T 5ESS switch is capable of recognizing a point-to-point configuration, eliminating the need for a SPID. All other switch types require a SPID.

Setting the Local Directory (LOC) Number

For ISDN dial backup, the LOC is stored in **STORED NUMBER 10**.

Table 8-1. AT Commands for Storing Phone Numbers

AT Command	Description
&Zn=	Store Phone Number
&Z9=	Enter SPID Number for ISDN dial backup
&Z10=	Edit LOC for ISDN dial backup

DBU Options for All Models

The **DBU OPTIONS** are used to select the modes of operation for the **DIAL BACKUP** features. There are ten standard options available with additional options for specific backup services. Table 8-2 on page 8-7 lists the DBU options and their AT commands for all models.

Automatic DBU

The **AUTOMATIC DBU** option specifies whether the unit automatically enters dial backup mode or waits for manual setup. The factory default setting is **DISABLE**.

Number to Dial

The **NUMBER TO DIAL** option offers a selection of stored numbers for the unit to automatically dial. If the leased line fails, and the DSU III DBU is set to originate, it dials the numbers (in chronological order) specified under this option to set up the dial backup line. The factory default setting is **DIAL STORED #1**.

Originate/Answer

This option specifies whether the DSU III DBU originates or waits to answer if the dedicated circuit fails. One end must be set to **ORIGINATE** and the other to **ANSWER**. The factory default setting is **ANSWER**.

When Out of Service (OOS)

When enabled, the DSU III DBU enters backup mode if an out-of-service condition is detected. The factory default setting is **ENABLE**.

No Receive (RX) Signal

When enabled, the DSU III DBU enters backup mode when a loss of signal is detected. The factory default setting is **ENABLE**.

No Sealing Current

When enabled, the DSU III DBU enters backup mode when a loss of sealing current is detected. The factory default setting is **ENABLE**.

When all 1s/0s

When this option is enabled, the DSU III DBU monitors the receive data for strings of 1s or 0s that are longer than the Fail Timer. If this condition is detected, the local DSU III DBU initiates a handshake routine with the remote unit to determine if the DTE is generating the constant data pattern or if the network has failed.

Auto Restore

Once the DDS circuit is restored, the DSU III DBU remains in backup until the DDS circuit is active for the length of time specified for the restore timer. The selection is entered in minutes (up to 255). If set to 0, the DDS must be restored manually. The factory default setting is **1 MINUTE**.

```
RESTORE TIMER  
(0=OFF)    ___  ___  MIN
```

Redial Counter

This option sets the number of times the DSU III DBU redials the far end when entering backup mode. The redial count, which is manually entered, can be up to a maximum of 99 attempts. If the DSU III DBU encounters a busy or reorder, it attempts to establish the call the specified number of times. The factory default setting is 5.

```
ENTER REDIAL  
COUNT:  __  __
```

Fail Timer

This option sets the amount of time the dedicated circuit failure condition must be active before the DSU III DBU attempts backup. The amount of time, which is manually entered, can be up to a maximum of 99 seconds. The factory default setting is 3 seconds.

```
AUTO DBU FAIL  
TIME:  __  __  SEC
```

Wait to Redial

This option works in conjunction with the preceding **REDIAL COUNTER**. It selects the amount of time between redial attempts to connect the backup line. The amount of time, which is manually entered, can be up to a maximum of 99 seconds. The factory default setting is 10 seconds.

```
WAIT TO REDIAL  
TIME:  __  __  SEC
```

Table 8-2. DBU Options AT Commands for All Models

DBU Options	AT CMD	Description
Automatic DBU		
1=Disabled	_K0	Automatic DBU disabled
2=Enabled	_K1	Automatic DBU enabled
Number to Dial		
1=DBU with #1	_B0	Dial stored #1
2=DBU with #2	_B1	Dial stored #2
Originate/Answer		
1=DBU Originate	_E0	Originates call if DDS fails
2=DBU Answer	_E1	Answers call if DDS fails
When Out of Service (OOS)		
1=Enabled	_G1	DBU when OOS
2=Disabled	_G0	No DBU for OOS
No Receive (RX) Signal		
1=Enabled	_H1	DBU when RX signal absent
2=Disabled	_H0	No DBU when RX signal absent
No Sealing Current		
1=Enabled	_I1	DBU when sealing current absent
2=Disabled	_I0	No DBU when sealing current absent
When all 1s/0s		
1=Disabled	_P0	No DBU when all 1s/0s detected
2=Enabled	_P1	DBU when all 1s/0s condition exists
Auto Restore	S31=x	Sets restore timer
Redial Counter	S57=x	Sets redial counter
Fail Timer	S58=x	Sets fail timer
Wait to Redial	S59=x	Sets time between redial attempts

DBU Options for 2-wire and 4-wire

Network Type

This option selects the company providing the switched digital service. When US Sprint is selected, an automatic echo canceler suppressor tone is emitted by the DSU III DBU when dialing. Options include: **AT&T/MCI/OTHER** and **US SPRINT**.

DBU Options for V.32 bis and V.34

Table 8-3 on page 8-9 shows the equivalent AT commands for setting **ERROR CONTROL**, **FLOW CONTROL**, and **COMPRESSION** options.

Error Control

This option determines the type of error control to be negotiated at the start of a V.32 bis or V.34 modem connection. The factory default setting is **AUTO V.42/MNP**.

Flow Control

This option is used to select the type of flow control used by the V.32 bis or V.34 modem. The factory default setting is **CTS ONLY**.

Compression

This option is used to select V.42 bis data compression for V.32 bis or V.34 operation when running asynchronously. When enabled, data throughput speeds as high as 57.6 kbps may be achieved. For synchronous applications, the speed is limited to a maximum of 14.4 kbps for the V.32 and 28.8 kbps for the V.34. The factory default setting is **ENABLED**.

Table 8-3. DBU Options AT Commands for V.32 bis and V.34 Backup

DBU Options	AT CMD	Description
Error Control		
1=Buffered	\N0	Normal operation. No error control. Allows speed matching, buffering, and flow control.
2=Direct	\N1	Direct operation. No error control, no buffer, and no flow control.
3=Reliable MNP	\N2	Reliable MNP operation. Uses MNP error control.
4=Auto MNP	\N3	Auto-Reliable MNP operation. Tries MNP error control first; uses normal operation if necessary.
5=Reliable V.42	\N4	Reliable V.42 (LAPM) operation. Uses V.42 (LAPM) error control. If V.42 (LAPM) error control cannot be used the call is disconnected.
6=Rel. V.42/MNP	\N5	Reliable V.42 (LAPM) or MNP operation. Uses either V.42 (LAPM) or MNP error control. If neither can be used the call is disconnected.
7=Auto V.42/MNP	\N6	Auto-Reliable V.42 (LAPM) or MNP operation. Tries to use V.42 (LAPM) error control first, and MNP error control next. If neither can be used, then Normal operation is used.
Flow Control		
1=Disabled	\Q0	Flow control disabled
2=XON/XOFF	\Q1	Enables XOn/XOff flow control
3=CTS Only	\Q2	Enables CTS flow control from DCE
4=RTS/CTS	\Q3	Enables CTS flow control from DCE and RTS from DTE
5=UN. XON/XOFF	\Q4	Unidirectional XOn/XOff
Compression		
1=Disabled	%C0	Compression disabled
2=Enabled	%C1	Compression enabled

DBU Options for ISDN

Switch Type

This option selects the type of telco CO switch providing the ISDN service. There are three options for ISDN switch types:

- AT&T 5ESS
- NT DMS-100
- National ISDN1

DBU Passcode

The dial backup passcode adds an additional level of security to the DSU III DBU. A passcode of one to ten characters can be programmed into the unit.

When a dial backup connection is established, the originate unit transmits a pre-programmed passcode to the answer unit over the dial backup connection before the connection is considered valid. The answer unit compares the received passcode to a pre-programmed passcode. If the passcode matches, the receive unit sends a Passcode OK message to the originate unit and goes on-line. If the passcode does not match, the receive unit sends an Invalid Passcode message to the originate unit and terminates the dial backup connection. If a passcode is not received by an answer unit with passcode enable, or if the Passcode OK message is not received by an originate unit with passcode enable, the dial backup connection is terminated.

Chapter 9 Dial Options

DIAL OPTIONS

The dial options available in the **DIAL** menu (4=Dial) vary whether the DSU III DBU is currently in dial backup mode or connected to the DDS line (see Figure 9-1).

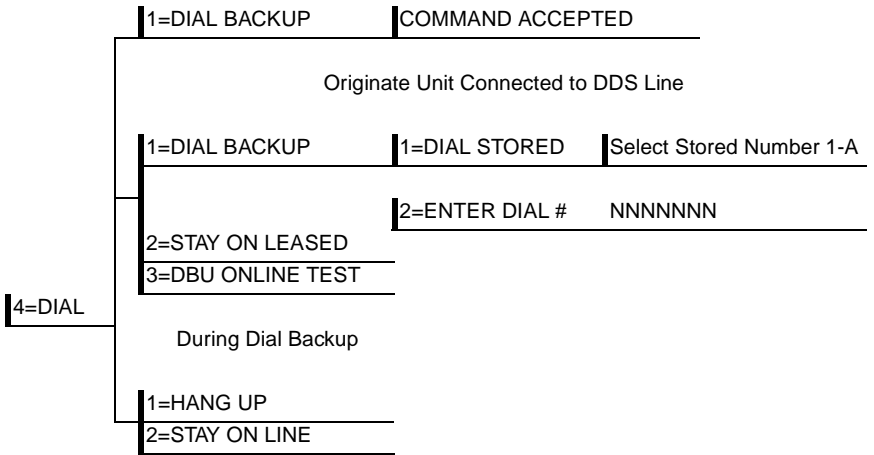

Figure 9-1. Dial Options Menu

Answer Unit Connected to DDS Line

Dial Backup

The message `COMMAND ACCEPTED` is displayed and the DSU III DBU waits for an incoming call. When an incoming call is detected the DSU III DBU answers the call and enters dial backup.

Originate Unit Connected to DDS Line

Dial Backup

The DSU III DBU prompts to dial a stored number or enter a number to dial for dial backup.

Stay on Leased

The DSU III DBU remains on the leased line and does not enter dial backup mode.

DBU Online Test

This option allows the dial backup connection to be tested manually without interrupting the data on the DDS. A stored or manually entered number can be used.



DBU ANSWER TEST must be enabled on the far end to perform a *DBU on-line test*.

Dial Options During Dial Backup

Hang Up

Terminates the dial backup connection and attempts to reestablish communication on the DDS line.

Stay On Line

This DSU III DBU remains in dial backup mode and returns to the **MAIN** menu.

STATUS

The status selection displays two lines of the current operational status of the network and the DTE interfaces.

After 30 seconds of no front panel operation the DSU III DBU automatically reverts to the **STATUS** display; see Figure 10-1.

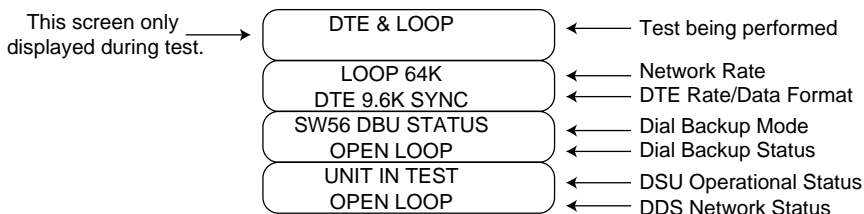

Figure 10-1. Status Display

Network Rate, DTE Rate, and Data Format

This display line (see Figure 10-1) indicates the current loop rate on the first line. The DTE data rate and format (as selected in configuration) are shown on the second line.

Dial Backup Information

Type of Dial Backup Service

This display line (see Figure 10-1 on page 10-1) indicates the type of dial backup service installed in the DSU III DBU. The following messages are displayed according to the dial backup option installed in the DSU III DBU:

DU DBU Status	2-wire Switched 56 backup option installed.
ISDN DBU Status	1 B+D Basic Rate ISDN backup option installed.
SW56 DBU Status	4-wire Switched 56 backup option installed.
V.32 DBU Status	V.32 backup option installed.
V.34 DBU Status	V.34 backup option installed.
DBU Status	No backup service option card installed
Not Installed	in the DSU III DBU unit.

Current Status of Dial Backup Mode

This display line (see Figure 10-1 on page 10-1) indicates the backup service status. Possible messages include the following:

Answering Call	The DSU III DBU detected an incoming call message and is initiating call setup procedure.
Call Disconnect	Call disconnect message received from the remote end.
Called Unit Busy	The unit called is currently busy and cannot be connected (ISDN only).
Dialing	The unit is dialing the selected number.
Going to DBU	The DSU III DBU is entering dial backup mode.
Idle	Messages are not being transmitted but the service is immediately available for use.
Incoming Call	Incoming call messages being received.
In Dial Backup	The DSU III DBU is currently in dial backup mode.

No RX Signal	Sealing current detected but no data signal received from telco.
No wink from CO	Switched 56 provider encountered a service problem (4-Wire SW56 only).
Not Installed	No dial backup option installed in the DSU III DBU.
OOS/OOF From Net	Out-of-service signal or out-of-frame condition exists. The call cannot be completed because the called terminal or the called terminal's access line is out of service or is faulty (2-wire and 4-wire SW56 only).
Open Loop	The physical connection to the backup line has been broken (2-wire and 4-wire SW56 only).
DBU Line in RDL	Remote end initiated a test.
Test From Telco	The network provider has activated the CSU loopback (2-wire and 4-wire SW56 only).
DBU Test Pattern	The DSU III DBU is currently performing a test with a pattern.
Waiting for Call	The originating DSU III DBU is waiting on a call from the remote end.

DSU Operation and Network Status

Current DSU III DBU Status

This display line (see Figure 10-1 on page 10-1) indicates current DSU III DBU status. Possible messages are:

Data Mode	In data mode, the data set ready (SR) and request to send (RTS) circuits are on, and the DSU III DBU is ready to send data.
Unit in Test	The DSU III DBU is currently in test mode, use the Arrows to scroll through the menus to display the type of test being performed.

Current DDS Network Status

This display line (see Figure 10-1 on page 10-1) displays the status of the main telco line. For normal operation this should display `LOOP IS NORMAL`, other possible messages are described as follows:

Answering Call	The DSU III DBU detects an incoming call.
Check Telco	The transmit and receive (Tx/Rx) pairs of the loop connection are reversed. The pairs should be swapped for normal operation.
Going To DBU	This message is displayed briefly while switching from the dedicated service to dial backup mode.
In Dial Backup	The DSU is in dial backup mode.
LL Test From Telco	An LL test has been initiated from the telco.
Loop is Normal	The DSU is connected to the dedicated line.
OOS/OOF	The telco is transmitting an out-of-service code.
Open Loop	The DDS physical connection has been broken.
Waiting for Call	The DBU module is waiting for a call.

DTE Control Leads and Status

Four additional DTE interface leads are displayed with their current status (on or off) displayed below. The leads are identified as follows:

TR	Data terminal ready
SR	Data set ready
LLB	Local loopback
RLB	Remote loopback.

Chapter 11 Testing and Troubleshooting

TEST OVERVIEW

The DSU III DBU performs a variety of diagnostic functions that isolate portions of the circuit to identify the problem source. Tests may be initiated and terminated from the front panel or the DTE interface. In asynchronous mode, AT commands can control the testing from the DTE interface. For synchronous operation, V.25 bis commands can provide test control.

The unit also responds to standard DDS network tests initiated from telco test centers. In addition, it can run several tests such as local and remote loopbacks to aid in problem isolation.

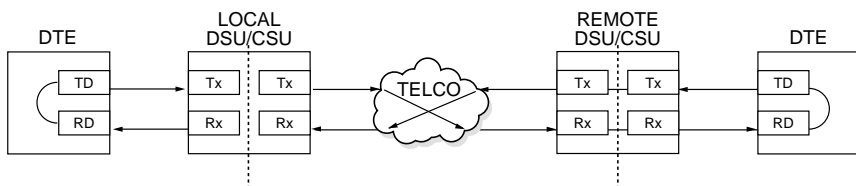

Figure 11-1. Normal Operation Before Initiating Loopback Test



All diagnostic tests disrupt data flow.

Initiating a Test

Initiate tests using the following procedure:

1. Select **TEST** from the **MAIN** menu by pressing **2** and then pressing **Enter**.
2. Specify **LOCAL**, **REMOTE**, or **DBU** testing by selecting the corresponding number, followed by **Enter**.
3. Use the up and **down** arrows to view test options.
4. Select a test from the available options by pressing the corresponding number, followed by **Enter**.

The example in Figure 11-2 shows the menu path for initiating a local **DTE AND LOOP** test.

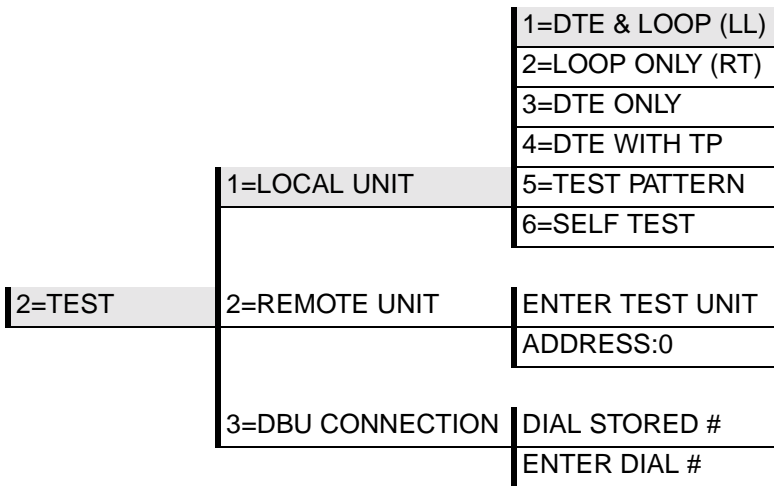

Figure 11-2. Initiating a Test

Once a test is initiated, `Please Wait` is displayed briefly followed by the status screen.

Test Status Display

The **TEST STATUS** display appears automatically during a test. The **TEST STATUS** display is similar to the status screen described in the chapter *Status* on page 10-1, with additional prompts for the type of test and the number of errors (for tests with a test pattern).

Figure 11-3 shows an example of a **TEST STATUS** display for a test with a test pattern.

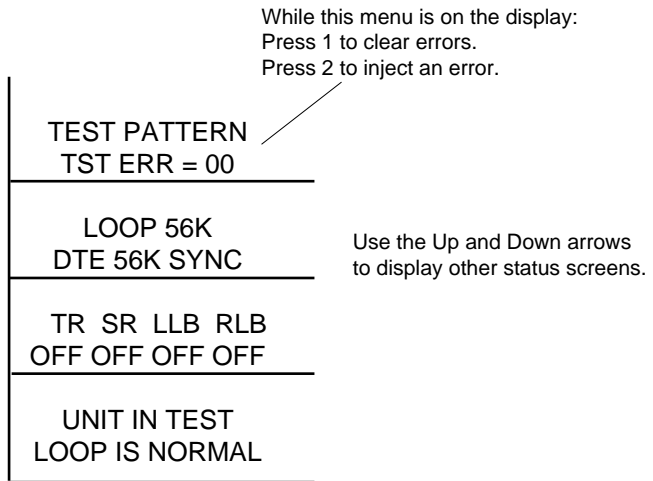

Figure 11-3. Sample Test Status Displays

Exiting a Test

During a test, press **Quick** to access the **EXIT TEST/DISPLAY STATUS** menu or press **Cancel** to return to the **MAIN** menu. The **EXIT TEST/DISPLAY STATUS** menu provides the following options, which are available only after a test has been initiated (see Figure 11-4 on page 11-4):

Exit Test	Exits the current test and returns to the MAIN menu.
Display Status	Reenters test display.

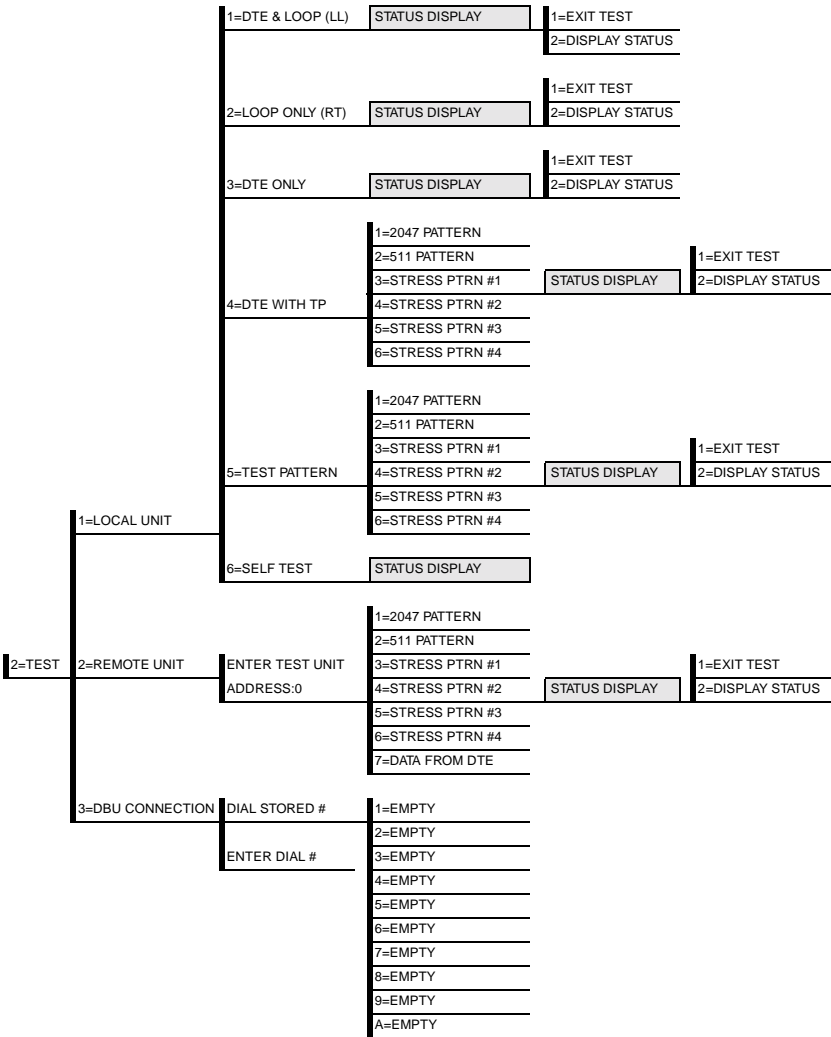

Figure 11-4. Complete Test Menu

TROUBLESHOOTING

This section is intended to provide a quick and easy means of diagnosing suspected problems associated with local or remotely attached ADTRAN DSU/CSUs.

Messages from the DSU/CSU

Messages on the LCD display and LEDs display information concerning the status of the unit and the local loop. If the Alarm LED is *On*, one or more of the messages shown in Table 11-1 is displayed on the LCD.



*The **STATUS** menu must be selected in order for the unit to display status messages. Pressing **Quick** returns to the **MAIN** menu where **STATUS** can be selected.*

Table 11-1. Messages from the DSU/CSU

Message	Meaning	Probable Cause	Action
LOOP IS NORMAL	Good local loop signal being received from the telco.	Indicates good local loop.	No action required; unit properly connected to telco circuit.
OPEN LOOP	Unit not receiving a signal from the telco.	Bad telco cable from the DSU to telco jack or bad circuit to telco.	Replace telco cable from DSU to wall jack. If a problem persists, contact telco provider.
NO RX SIGNAL	Unit detects sealing current but no data signal from telco	Bad conductor in telco cable from DSU to telco jack or bad circuit to telco.	Replace telco cable from DSU to wall jack. If a problem persists, contact telco provider.
OOS/OOF_FROM NET	Unit detects an out-of-service or out-of-frame condition from the telco.	Telco is having problems with DDS circuit or remote unit is turned off or disconnected.	Check remote unit. Contact telco service provider.
CHECK TELCO LINE	Transmit/receive pair reversal detected.	Telco wall jack wired incorrectly.	Switch wire pairs in wall jack or contact telco service provider.
TEST FROM TELCO	Telco activated a loopback to test the DDS circuit.	Telco is testing circuit.	Wait until test is complete or contact telco service provider.

Troubleshooting New Installs

Before initiating diagnostics on a newly installed unit and/or DDS circuit and before contacting ADTRAN Technical Support, please check the items in Table 11-2 to ensure the unit is configured properly.

After verifying the items listed in Table 11-2 the unit should operate properly and display the following:

```
DATA MODE
LOOP IS NORMAL
```

If a status message other than DATA MODE LOOP IS NORMAL is shown, begin performing diagnostics described in the section *Test Sequence for Troubleshooting New Installs or Existing Circuits* on page 11-7.

Table 11-2. Troubleshooting New Installs

Configuration Item to Check	Option Selection	Action
DTE Type	RS-232 or V.35	Select the type of DTE interface option to connect to the DSU/CSU from the configuration menu.
Loop Rate	Auto, 2.4 to 64 kbps	Select the DDS loop rate of the DDS circuit from the configuration menu.
Data Format	Async or Sync	Select the type of data to be used from the configuration menu.
DTE Cable	N/A	Verify DTE cable connection to the proper DTE connector on the DSU/CSU.
Telco Cable	N/A	Verify the telco cable is securely connected to the DSU/CSU and wall jack.
Power the unit Off and then On.	N/A	Verify the unit passes self test during power-up (displayed on the LCD).

Test Sequence for Troubleshooting New Installs or Existing Circuits

If your DSU is suspected of having problems, perform a **SELF TEST** to determine if the unit is in good health.

If your DSU is receiving excessive errors requiring retransmission of data, first perform a **DTE WITH TEST PATTERN** to determine if the unit's internal transmitter and receiver is operating error free. If problem persists, perform a **REMOTE TEST** to verify the connection between the local and remote unit is error free. Run the test using all available test patterns.



If an external BERT tester is available, these additional tests may be performed:

- *DTE & Loop Test*
- *DTE Only Test*
- *Loop Only Test*

If the unit fails any of these tests or the problem has not been determined, contact ADTRAN Technical Support; see the back of this manual.

LOCAL UNIT DIAGNOSTICS

The local DSU III DBU can perform six different tests; see Table 11-3.

Table 11-3. Test AT Commands

Front Panel Display	AT Command	Description
DTE & Loop (LL)	&T10	TD/RD and RX/TX Loopbacks
Loop Only (RT)	&T11	RX/TX Loopback at DTE Interface
DTE Only	&T1	TX/RX Loopback at Network Interface
DTE with TP	&T8	TX/RX Loopback with Test Pattern
Test Pattern	&T9	Transmit/Receive Test Pattern
Self Test	Z	Check Internal Components (Resets Unit)
Exit Test	&T0	Stops test, returns to data mode
TD = Customer Transmit Data RD = Customer Receive Data TX = Network Transmit Data RX = Network Receive Data		

The test patterns shown in Table 11-4 on page 11-9 are available for the **DTE WITH TEST PATTERN** and **TEST PATTERN** tests.

Table 11-4. DTE With Test Pattern Commands

Front Panel	AT Command	Description
1=2047 PATTERN	_T0&T8	Standard 2047 random data pattern.
2=511 PATTERN	_T1&T8	Standard 511 random data pattern.
3=STRESS PTRN #1	_T2&T8	Stress pattern with alternating high and low ones densities. Repeated pattern of 100 octets: 1111 1111, followed by 100 octets: 0000 0000.
4=STRESS PTRN #2	_T3&T8	Stress pattern with alternating medium and low ones densities. Repeated pattern of 100 octets: 0111 1110, followed by 100 octets: 0000 0000.
5=STRESS PTRN #3	_T4&T8	Stress pattern with medium ones density. Continuous series of octets: 0011 0010.
6=STRESS PTRN #4	_T5&T8	Stress pattern with low ones density. Continuous series of octets: 0100 0000.

DTE & Loop (LL)

Test Description

The **DTE & LOOP** test splits the DSU III DBU into two separate DTE and loop interface sections and then loops the receive data of each interface back to its respective transmit data. The **DTE & LOOP** test provides a bidirectional loopback at the DSU/CSU. Figure 11-5 illustrates the loopback points and the signal paths for this test.

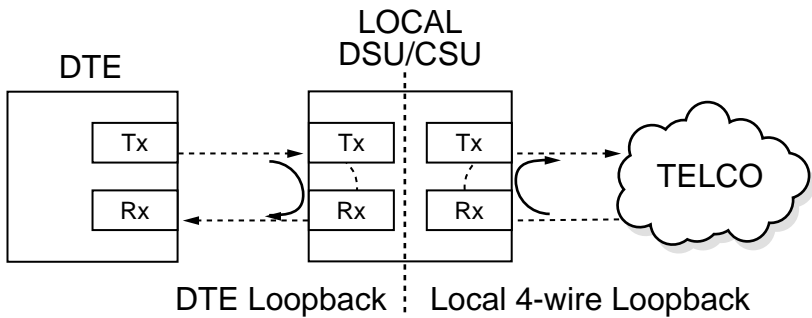

Figure 11-5. DTE & Loop Test

Test Purpose

The **DTE & LOOP** test is used for the following purposes:

- Verify integrity of the DTE interface and cable.
- Provide a loopback for network tests.

Initiating

Follow the menu path outlined in Figure 11-6 to initiate a **DTE & LOOP** test.

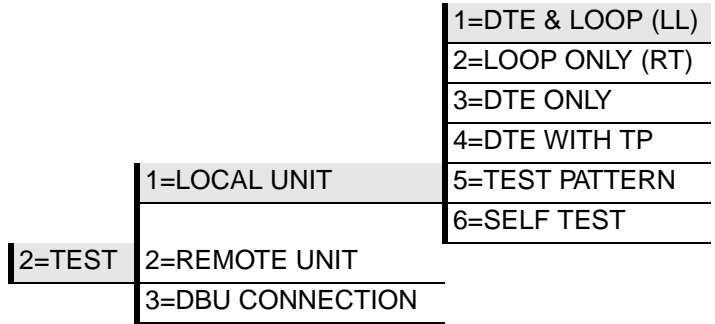

Figure 11-6. Initiating a DTE & Loop Test

Interpreting Test Results

A BERT tester must be used to interpret the test results of a **DTE & LOOP** test.

Loop Only (RT)

The **LOOP ONLY (RT)** test allows the loop interface and a major portion of the DTE interface for the local DSU III DBU to be tested from the remote site over the actual communication circuit. Figure 11-7 illustrates the loopback point and the signal paths for this test.

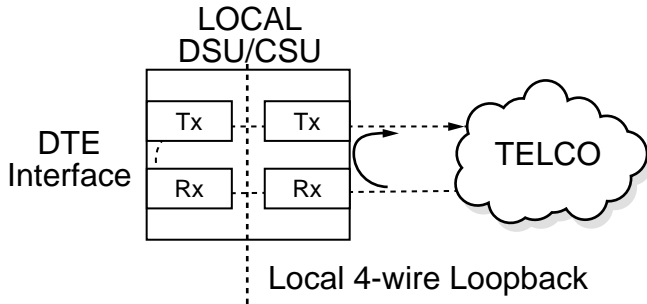

Figure 11-7. Loop Only Test

Test Purpose

The **LOOP ONLY** test is used to provide a loopback for network tests.

Initiating

Follow the menu path outlined in Figure 11-8 on page 11-13 to initiate a **LOOP ONLY** test.

		1=DTE & LOOP (LL)
		2=LOOP ONLY (RT)
		3=DTE ONLY
		4=DTE WITH TP
	1=LOCAL UNIT	5=TEST PATTERN
		6=SELF TEST
2=TEST	2=REMOTE UNIT	
	3=DBU CONNECTION	

Figure 11-8. Initiating a Loop Only Test

Interpreting Test Results

The **LOOP ONLY** test is used for the purpose of looping the DDS circuit back to the telco. No test results are available from the local DSU III DBU.

DTE Only

The **DTE ONLY** test provides a method for testing both the DTE interface drivers and receivers of the local DSU III DBU plus its loop transmitter and receiver. For this test, the loop transmit data is connected to the loop receive data at a point close to the physical network interface. This test can be used to verify proper operation between the local DTE and the local DSU III DBU.



When this test is implemented, the far unit receives an OOS/OOF message from the network and enters an alarm state.

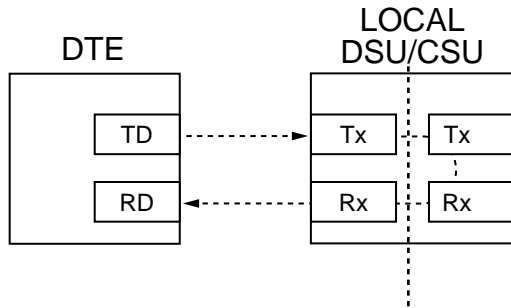

Figure 11-9. DTE Only Test Diagram

Test Purpose

The **DTE ONLY** test is used for the following purposes:

- Verify integrity of the DTE interface.
- Verify integrity of connection between DTE and DSU III DBU.

Initiating

Follow the menu path outlined in Figure 11-10 on page 11-15 to initiate a **DTE ONLY** test.

		1=DTE & LOOP (LL)
		2=LOOP ONLY (RT)
		3=DTE ONLY
		4=DTE WITH TP
	1=LOCAL UNIT	5=TEST PATTERN
		6=SELF TEST
2=TEST	2=REMOTE UNIT	
	3=DBU CONNECTION	

Figure 11-10. Initiating a DTE Only Test

Interpreting Test Results

A BERT tester must be used to interpret the test results of a **DTE ONLY** test.

DTE With Test Pattern

The **DTE WITH TP** (test pattern) test is similar to the **DTE ONLY** test described previously except the test pattern is generated using the DSU/CSU internal test pattern generator. This test can be used to detect deficiencies within the internal drivers and receivers of the DSU III DBU. Figure 11-11 illustrates the loopback point and the data paths for this test.

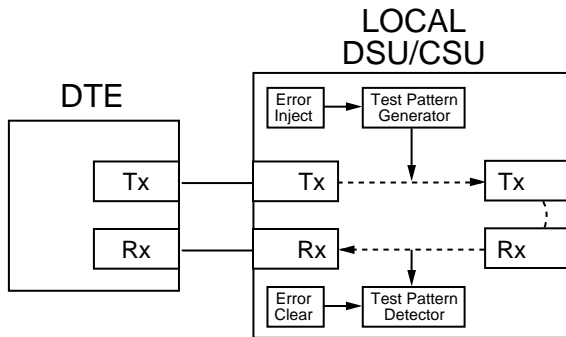

Figure 11-11. DTE with Test Pattern

Test Purpose

A DTE test using a test pattern is used for the following purposes:

- Verify integrity of the DTE interface.
- Verify integrity of connection between DTE and DSU III DBU.

Initiating

Follow the menu path outlined in Figure 11-12 on page 11-17 to initiate a **DTE TEST WITH TEST PATTERN**.

		1=DTE & LOOP (LL)	1=2047 PATTERN
		2=LOOP ONLY (RT)	2=511 PATTERN
		3=DTE ONLY	3=STRESS PTRN #1
		4=DTE WITH TP	4=STRESS PTRN #2
	1=LOCAL UNIT	5=TEST PATTERN	5=STRESSPTRN #3
		6=SELF TEST	6=STRESS PTRN #4
2=TEST	2=REMOTE UNIT		
	3=DBU CONNECTION		

Figure 11-12. Initiating a DTE Test with Test Pattern

Interpreting Test Results

If the unit is functioning properly, the DSU III DBU displays:

```
DTE WITH TP
TST ERR=XX
```

The first line of the display indicates the type of test being performed while the second line of the display indicates the number of errors accumulated by the test pattern detector.

If errors occur during this test, the test error count can be reset to zero by pressing **1**. To verify proper operation of this test, single bit errors can be injected into the transmitted test pattern by pressing **2**. These errors appear on the `TEST ERR` display.

Test Pattern

The **TEST PATTERN** option converts the local DSU III DBU into a BERT tester for the purpose of testing the DDS circuit. If this test is used, the remote DSU/CSU must be in loopback or transmitting a test pattern. Figure 11-13 illustrates the data paths for this mode.

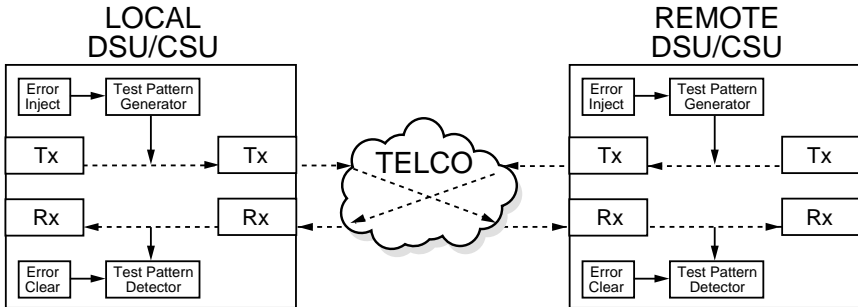

Figure 11-13. Test Pattern Only

Test Purpose

Testing using a test pattern is used for the following purposes:

- Transmits user-selected test pattern using an internal test pattern generator, and compares the received data using internal test pattern detector to detect if there are any errors on the DDS circuit.
- Injects errors and verifies the unit transmits data across the communication circuit to the remote unit.
- Helps determine from which direction the circuit is receiving errors.

Initiating

Follow the menu path outlined in Figure 11-14 to initiate a test using a test pattern.

		1=DTE & LOOP (LL)	1=2047 PATTERN
		2=LOOP ONLY (RT)	2=511 PATTERN
		3=DTE ONLY	3=STRESS PTRN #1
		4=DTE WITH TP	4=STRESS PTRN #2
	1=LOCAL UNIT	5=TEST PATTERN	5=STRESSPTRN #3
		6=SELF TEST	6=STRESS PTRN #4
2=TEST	2=REMOTE UNIT		
	3=DBU CONNECTION		

Figure 11-14. Initiating a Test Using a Test Pattern

Interpreting Test Results

If the unit is functioning properly, the test error count should be 0.

Self Test

The **SELF TEST** verifies current operation of the DSU III DBU. It can be performed at any time and is recommended if there is any question about the DSU's health.

Test Purpose

The purpose of this test is to determine if the DSU is functioning properly.

Initiating

Follow the menu path outlined in Figure 11-15 to initiate a test using a test pattern.

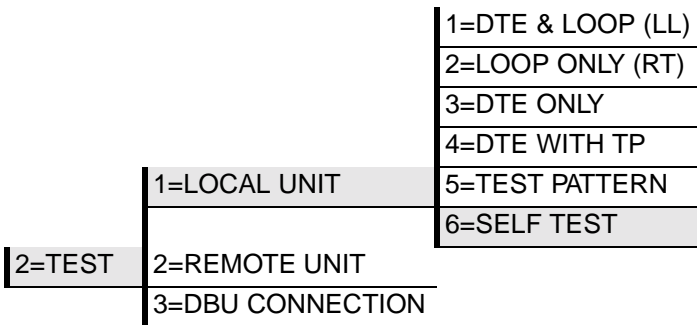

Figure 11-15. Initiating a Self Test

Interpreting Test Results

Once **SELF TEST** is activated, the LEDs cycle on and off as the system runs the self test. A pass or fail status will be displayed on the LCD along with a checksum indicating the current firmware revision.

REMOTE UNIT DIAGNOSTICS

A remote DSU III DBU can perform seven different tests; see Table 11-5.

Table 11-5. Remote Tests and AT Commands

Front Panel	AT Command	Description
1=2047 PATTERN	_T0&T7	Standard 2047 random data pattern
2=511 PATTERN	_T1&T7	Standard 511 random data pattern
3=STRESS PTRN #1	_T2&T7	DDS Stress Pattern #1
4=STRESS PTRN #2	_T3&T7	DDS Stress Pattern #2
5=STRESS PTRN #3	_T4&T7	DDS Stress Pattern #3
6=STRESS PTRN #4	_T5&T7	DDS Stress Pattern #4
7=DATA FROM DTE	&T6	Data from DTE

The **REMOTE UNIT** submenu allows a remotely installed DSU to be placed into loopback. There are six test patterns to choose from or **DATA FROM DTE** may be selected.

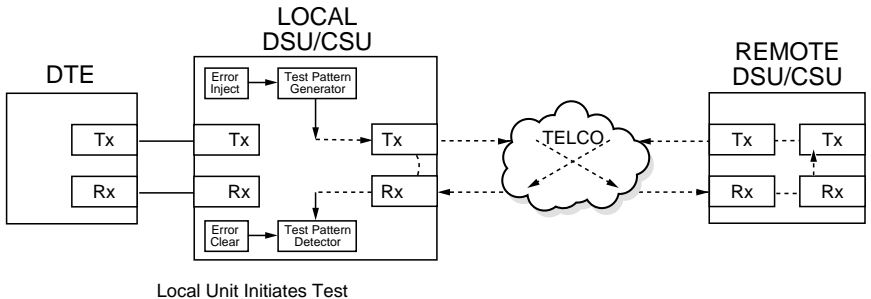

Figure 11-16. V.54 RDL with Test Pattern

Test Purpose

The test purpose is to test the local DSU, the DDS circuit, and the remote DSU.

Initiating

Follow the menu path outlined in Figure 11-17 to place a remote DSU III DBU into loopback.

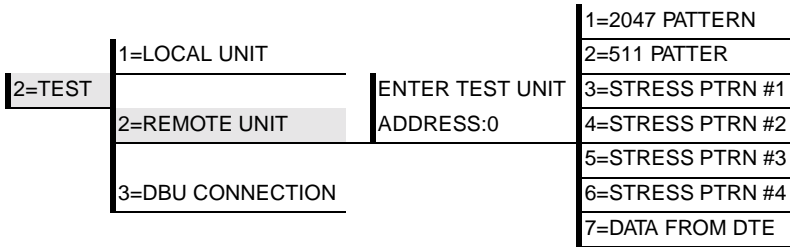

Figure 11-17. Initiating a Remote Test

After selecting **REMOTE UNIT** from the menu, the following prompt is displayed for entering the address for the remote unit:

```
Enter Test Unit
Address:XX
```

Use the number keys to type the address of the remote DSU, then press **Enter**. The test pattern selections are displayed. After a test pattern is selected, the system briefly displays `Please Wait`.

Test Results

If the test is successful the status menu is displayed. If not, `Unable to Execute Test` is displayed.

Interpreting Test Results

If the unit is functioning properly, the test error count should be 0.

DBU CONNECTION

When the DSU III DBU is equipped with a dial backup option, the **DBU CONNECTION** option appears as one of the **TEST** menu selections. This test allows the dial backup network to be tested while data is transmitted on the main line.

When this option is selected, choose a stored number or enter a number to dial. After establishing DBU connection, the DSU III DBU designated at the answer unit is placed into loopback and a test pattern is transmitted from the originate unit to the answer unit. Receive data is checked for errors and the results displayed on the front panel. While running this test, errors may be injected by pressing **2** and cleared by pressing **1**. During the DBU test the LEDs scan back and forth and the Test LED is *On*.



When running at a substrate over a 56k or 64k loop (or a 64k loop with Scrambler activated), the DSU will not send data during a DBU test.

*The **DBU ANSWER TEST** option must be enabled. Enabling **DBU ANSWER TEST** does not affect the unit during dial backup.*

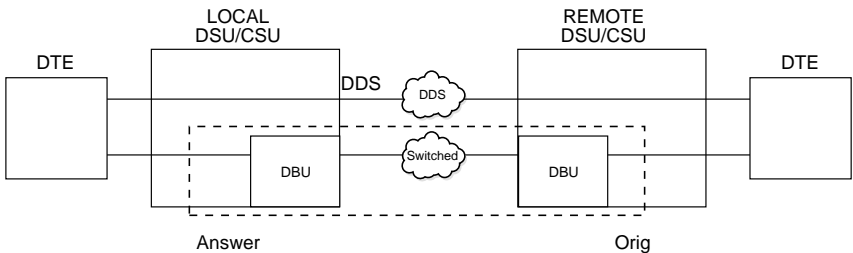

Figure 11-18. DBU Connection Test

Test Purpose

The purpose of this test is to verify the DBU circuit and DBU modules in both the local and remote DSU III DBU are functioning properly.

Initiating

Follow the menu path outlined in Figure 11-19 to place a remote DSU III DBU into loopback.

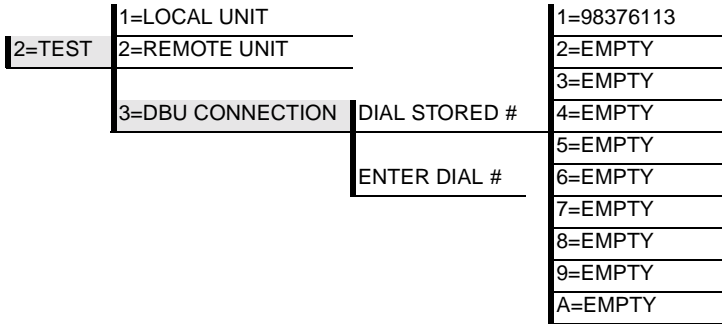

Figure 11-19. Initiating a DBU Connection Test

Interpreting Test Results

If the unit is functioning properly, the DSU III DBU displays:

```
DBU TEST PATTERN  
TST ERR = 0000
```

Chapter 12 Manual Command

MANUAL COMMAND

The **MANUAL COMMAND** option is a shortcut method for entering configuration and control commands for the DSU III DBU.

The first display prompts the user to enter the command number.

```
COMMAND : 00
```

Figure 12-1 on page 12-2 shows the menu path for manual command. The available manual commands are listed in Table 12-1 on page 12-3.

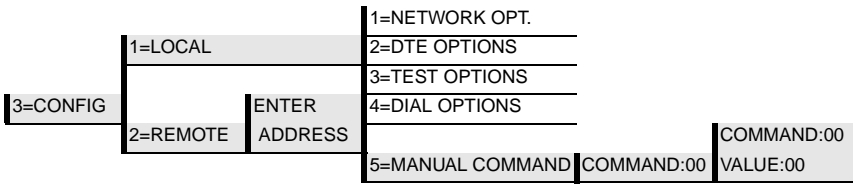

Figure 12-1. Manual Command

Use the number keys to enter the hexadecimal command number. Press **Enter** to complete. Once the command number is entered, the display shows both the command number and the present value or setting for the command. The command value can be edited or reissued with the existing value.

```
COMMAND : XX
VALUE : 00
```

Use the number keys to enter the hexadecimal value. Press **Enter** to complete. The system briefly displays `Command Accepted` and returns to the active menu.

Table 12-1. Manual Commands

Command Description	Command	Value
AT Command Echo		
Disable	82	00
Enable	82	01
AT Result code		
Enable	85	00
Disable	85	01
AT Long or Short code		
Short form (Numeric)	86	00
Long form (Verbose)	86	01
AT Escape Character	2	00 to FF
AT CR Character	3	00 to FF
AT LF Character	4	00 to FF
AT BS Character	5	00 to FF
AT Escape Char. Timer	0C	00 to FF
Abort Call Timer	7	00 to FF
DTR Recognize Delay	19	00 to FF
DTR Initiated Command Timeout	28	00 to FF
Load Factory Opt.		
Option Set #1	8A	00
Option Set #2	8A	01
Option Set #3	8A	02
Option Set #4	8A	03
Network Address Lock		
Network Addr. Unlock	C3	00
Network Addr. Lock	C3	01
Front Panel En/Dis		
Disable	AA	00
Enable	AA	01

Appendix A AT Commands

Table A-1 shows the AT commands available for the DSU III DBU.

Table A-1. AT Commands

Command	Title	Default
A/	Re-execute Command	none
ATA	Answer	none
ATDn	Dial Number	none
ATE	Echo Command	1
ATH	Hang Up Call	none
ATO	Go Online	none
ATQn	Result Code Display	0
ATSn?	Read S-Register	none
ATSn=x	Write to S-Register	none
ATVn	Result Code From Firmware	1
ATZ	Self Test	none
AT&Cn	DCD Option	0
AT&Dn	DTR Option	0
AT&Fn	Restore Factory Options	none
AT&Kn	Flow Control	none
AT&Ln	Network Type	0
AT&Qn	DTE Data Format	0
AT&Rn	CS Options	0
AT&Sn	SR Options	0
AT&Tn	Test Commands	0
AT&V	View Current Configuration	none
AT&Xn	Transmit Clock	0
AT&Zn=x	Store Phone Number	none

Table A-1. AT Commands (Continued)

Command	Title	Default
AT\Nn	MNP Option (V.32 DBU)	0
AT\Tn	Inactivity Timer	
AT%Bn	Loop Rate Select	0
AT%Cn	Compress Option (V.32 DBU)	0
AT%Kn	DTE Rate Select	
AT%P	Password Control	0
AT%P=x	Password Entry	0
T%P>x	Password Verify	0
AT%Rx	Initiate Remote Config.	
AT%Tn	Anti-stream Option	0
AT_An	LLB Control	0
AT_Bn	DBU Number to Dial	0
AT_Cn	SR Control During Test	0
AT_Dn	RTS-CTS Delay	0
AT_En	DBU Originate/Answer	0
AT_Fn	Scrambler Control	0
AT_Gn	DBU When OOS	0
AT_Hn	DBU When No RX Signal	0
AT_In	DBU When No Sealing Current	0
AT_Jn	Auto Answer Enable/Disable	0
AT_Kn	DBU Enable/Disable	0
AT_Ln	DTE Routing Main/Backup	0
AT_N=xx	Set Network Address	none
AT_Pn	Front Panel Enable/Disable	0
AT_RR	LB Enable/Disable	0
AT_S=xx	Set Serial Number	none
AT_Tn	Select Test Pattern	0
AT_Xn	Clock Source Select	0
AT_Yn	Secondary Channel Rate Select	0
AT&T10	Local DTE & Loop	none
AT&T11	Local Loop Only	none
AT&T1	Local DTE Only	none

Table A-1. AT Commands (Continued)

Command	Title	Default
AT&T8	Local DTE with TP	none
AT&T9	Local Test Pattern	none
AT&T0	Exit Test	none
AT_T0&T7	Remote test using 2047 pattern	none
AT_T1&T7	Remote test using 511 pattern	none
AT_T2&T7	Remote test using stress PTRN #1	none
AT_T3&T7	Remote test using stress PTRN #2	none
AT_T4&T7	Remote test using stress PTRN #3	none
AT_T5&T7	Remote test using stress PTRN #4	none
AT_T0&T8	Local test using 2047 pattern	none
AT_T1&T8	Local test using 511 pattern	none
AT_T2&T8	Local test using stress PTRN #1	none
AT_T3&T8	Local test using stress PTRN #2	none
AT_T4&T8	Local test using stress PTRN #3	none
AT_T5&T8	Local test using stress PTRN #4	none
AT&T6	Remote test using data from DTE	none

Appendix B Default Configuration Profiles

The DSU III DBU contains four different user profiles (sets of configurations options) stored in read-only memory; see Table B-1 on page B-2. The unit is shipped from the factory with profile 1 loaded into the nonvolatile configuration memory. See the chapters *Installation* on page 2-1 and *Manual Command* on page 12-1 for more information.

Profile 1

Profile 1 is configured for a 56 kbps, synchronous, point-to-point or dial-up operation with a V.35 connector. Automatic DBU has been disabled for this configuration profile.

Profile 2

Use profile 2 for a 56 kbps, asynchronous, point-to-point or dial-up operation, with an EIA-232 connector. Automatic DBU has been disabled for this configuration profile.

Profiles 3 and 4

Profiles 3 and 4 are used for enabling dial backup using two DSU III DBU units. One unit must be set for **Answer** and the other for **Originate**. Use profile 3 to set the remote unit to **Answer** and profile 4 to set the host unit to **Originate**.

Table B-1. Default Configuration Profiles

	Profile Numbers			
	(00) 1	(01) 2	(02) 3	(03) 4
Manual Command				
Escape Character	43=2BH	43=2BH	43=2BH	43=2BH
CR Character	13=0DH	13=0DH	13=0DH	13=0DH
LF Character	10=0AH	10=0AH	10=0AH	10=0AH
BS Character	8	8	8	8
DBU Abort Call Timer	50=32H	50=32H	50=32H	50=32H
Escape Guard Timer	50=32H	50=32H	50=32H	50=32H
Command Echo	Enable	Enable	Enable	Enable
Result Code	Enable	Enable	Enable	Enable
Long or Short Code	Long	Long	Long	Long
Test Pattern Type	2047	2047	2047	2047
CS Delay	Short	Short	Short	Short
DTR Recog. Delay (x100ms)	3	3	3	3
DTR Command Timeout (x100)		8	8	8
Front Panel En/Dis	Enable	Enable	Enable	Enable
Inactivity Timer	Off	Off	Off	Off
AT Password Control	Disable	Disable	Disable	Disable
Network Options				
Loop Rate	AUTO	AUTO	AUTO	AUTO
Network Address	0	0	0	0
Remote Conf. En/Dis	Enable	Enable	Enable	Enable
Clock Source	From Network	From Network	From Network	From Network
DTE Options				
Remote DSU Address	0	0	0	0
DTE Rate (56k loop)	56k/57.6k	56k/57.6k	56k/57.6k	56k/57.6k
Scrambler Mode	OFF	OFF	OFF	OFF
Connector Type	V.35	RS232	V.35	V.35
DTE Data Format	SYNC	ASYN	SYNC	SYNC
DTE Command Options	DIS	DIS	DIS	DIS
Transmit Clock	Normal	Normal	Normal	Normal
CS Options	Follow RS	Follow RS	Follow RS	Follow RS
Anti-stream Timer	Timer Off	Timer Off	Timer Off	Timer Off
CD Option	Normal	Normal	Normal	Normal
TR Options	Ignored	Ignored	Ignored	Ignored
SR Options	Off Test+OOS	Off Test+OOS	Off Test+OOS	Off Test+OOS
Secondary Channel Rate	OFF	OFF	OFF	OFF
Test Options				
Test Timeout	Off	Off	Off	Off
RDL En/Dis	RDL Accepted	RDL Accepted	RDL Accepted	RDL Accepted
EIA Controlled LLB	Disable	Disable	Disable	Disable

Table B-1. Default Configuration Profiles (Continued)

	Profile Numbers			
	(00) 1	(01) 2	(02) 3	(03) 4
EIA Controlled RLB	Disable	Disable	Disable	Disable
DBU Answer Test	Disable	Disable	Disable	Disable
Dial Options				
Automatic DBU	Disable	Disable	Enable	Enable
DBU Number to Dial	#1	#1	#1	#1
DBU Originate/Answer	Answer	Answer	Answer	Originate
DBU when OOS	Enable	Enable	Enable	Enable
DBU when No RX Signal	Enable	Enable	Enable	Enable
DBU when No Sealing Current	Enable	Enable	Enable	Enable
DBU Auto Restore Timer	1 minute	1 minute	1 minute	1 minute
DBU Redial Counter	5	5	5	5
DBU Fail-Timer (x10 seconds)	3	3	3	3
DBU Redial Wait Time	10	10	10	10
When all 1s/0s	Disable	Disable	Disable	Disable
Network Type	AT&T	AT&T	AT&T	AT&T
Error Control	Auto V.42/MNP	Auto V.42/MNP	Auto V.42/MNP	Auto V.42/MNP
Flow Control (V.32)	CTS Only	CTS Only	CTS Only	CTS Only
Data Compression (V.32)	Enabled	Enabled	Enabled	Enabled

Appendix C DSU to Modem Interconnect

MODEM TAIL CIRCUIT APPLICATION

A DSU to modem interconnect diagram for a modem tail circuit application is shown in Figure C-1.

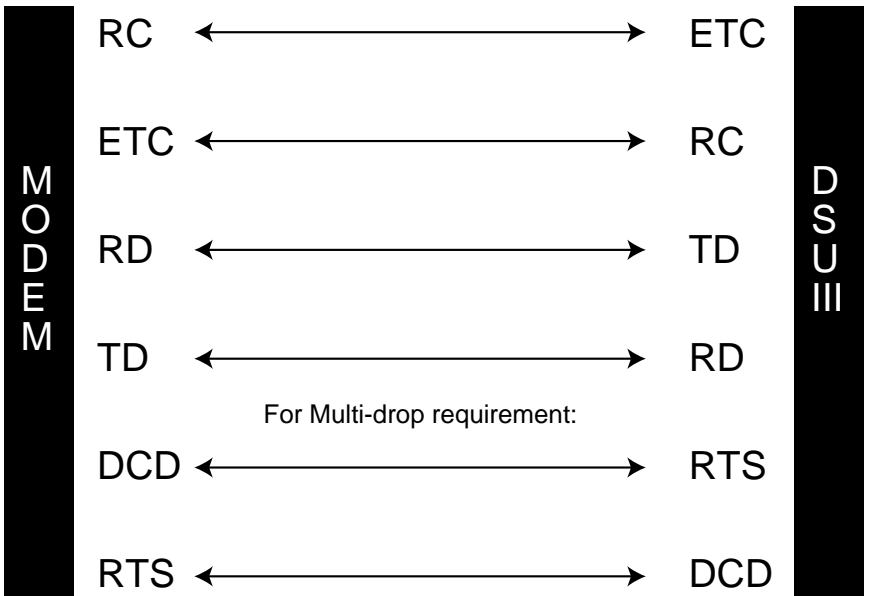

Figure C-1. DSU to Modem Interconnect

Appendix D EIA-232 Connector

56 AND 64 KBPS APPLICATION

The EIA-232 connector, shown in Figure D-1, may be used for 56 and 64 kbps applications. Using the **External Clock** option and this cable should eliminate data errors caused by excessive delays in the DTE transmit clock receiver and transmit data driver. When creating this cable at the DTE interface EIA-232 connector, tie the transmit clock lead (TC) to the external transmit clock lead (ETC) as shown.

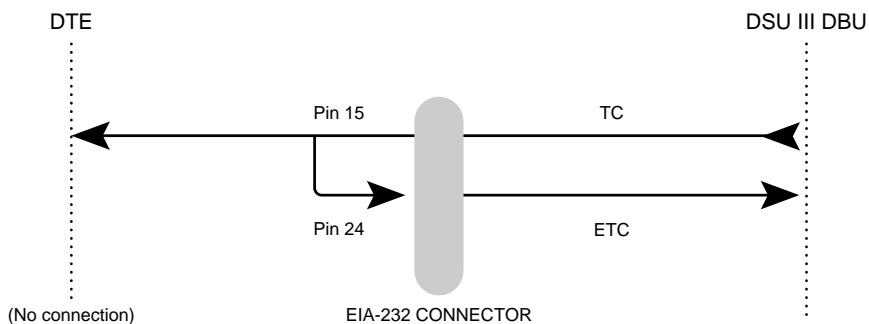

Figure D-1. EIA-232 Connector

SPECIFICATIONS AND FEATURES

This section describes the standard specifications and features incorporated in the DSU III DBU.

Operating Modes

Dedicated DDS: Point-to-point and multipoint

Switched Backup: (Automatic or manual) 4-wire Switched 56, 2-wire Switched 56, V.32 bis/V.42 bis, or ISDN (1B+D)

Data Rates

Dedicated mode service rates: 2.4, 4.8, 9.6, 19.2, 38.4, 56, and 64 kbps

Switched mode service rate: 56 kbps and 64 kbps

DTE Rates

DTE-to-loop rate matching in both dedicated and switched modes

Synchronous rates: 2.4, 4.8, 9.6, 19.2, 38.4, 56, and 64

Asynchronous rates: 2.4, 4.8, 9.6, 19.2, 38.4, and 57.6 kbps

DTE Interface Data Rates

V.35 and EIA-232: up to 57.6 kbps async, up to 64 kbps sync

FCC Approval

FCC part 15, class A and Part 68

DTE Interfaces

Both EIA-232 and V.35 electrical and physical DTE interfaces

Data Buffering

Internal slack buffer

Clocking

Normal DDS or private network tributary
(slaved to network receive clock)

Private network master (internal clock)

Private network master (slaved to external clock)

Diagnostics

Network: CSU and DSU loopbacks

User: Local DTE and loop, remoteV.54

Test Patterns: 2047, 511, DDS, and stress patterns 1-4

Line Requirements

Loop transmission parameters as defined in:

AT&T PUB 62310: Dedicated DDS

AT&T PUB 41468: Switched 56

SPRINT TS 0046: Switched 56

Line Interface

RJ-48S, 4-wire, full duplex

Backup as applicable

Receiver Sensitivity

-45dB at all rates

Environment

Operating Temperature: 0 to 50 °C (32 to 122 °F)

Storage Temperature: -20 to 70 °C (-4 to 158 °F)

Physical

Relative Humidity: Up to 95%, non-condensing

Dimensions: 2.25"H, 8.75"W, 10.25"D

Weight: 3 lbs

Power

115 VAC, 60 Hz, 8 W

2047

A pseudorandom test pattern that is repeated every 2047 bits; used to test DSU/CSUs.

511

A pseudorandom test pattern that is repeated every 511 bits; used to test DSU/CSUs.

2-Wire Switched 56

A Northern Telecom proprietary 56 kbps switched digital data service offered by telco service providers and delivered to users over a single pair of copper wires.

4-Wire Switched 56

An AT&T proprietary 56/64 kbps switched digital data service offered by telco service providers and delivered to users over four copper wires.

AT&T Publication 41458

An AT&T specification titled "Special Access Connections to the AT&T Communications Network," used to design compatibility into DSU/CSU products.

AT&T Publication 62310

An AT&T specification titled "Digital Data System Channel Interface Specification," used to design compatibility in DSU/CSU products.

BERT

Bit error rate test. A known pattern of bits is transmitted and the errors received are counted to figure the bit error rate. The idea is to measure the quality of data transmission. The bit error rate is the ratio of received bits that are in error, relative to the number of bits received. Usually expressed in a power of 10.

CD

Carrier Detect. A signal generated by a modem or DSU/CSU. CD indicates its connection status. If the CD light is on, the device is speaking to another device.

channel service unit

CSU. A DCE device used to connect a digital phone line (T1 or Switched 56 line) coming in from the phone company to either a multiplexer, a channel bank, or directly to another device producing a digital signal (for example a digital PBX, a PC, or data communications device). A CSU performs certain line-conditioning and equalization functions, and responds to loopback commands sent from the central office. A CSU regenerates digital signals. It monitors them for problems, and provides a way of testing the digital circuit.

clocking

An oscillator-generated signal that provides a timing reference for a transmission link. A clock provides signals used in a transmission system to control the timing of certain functions. The clock has two functions: (1) to generate periodic signals for synchronization and (2) to provide a time base.

control port

An interface to a device or system that allows users to issue commands pertaining to dialing, configuration, diagnostics, management, etc.

CPE

Customer premise equipment. All telecommunications terminal equipment located on the customer premises, including telephone sets, private branch exchanges (PBXs), data terminals, and customer-owned coin-operated telephones.

CS

See CTS.

CSU

See *Channel Service Unit*.

CSU loopback

A telco initiated test which loops the CSU portion of the DSU/CSU back to the telco and allows the telco to test the DDS circuit as well as the CSU portion of the customer's DSU/CSU.

CTS

Clear to send. A signal on the DTE interface indicating that the DCE is clear to send data. Sometimes referred to as CS.

data compression

A technique for encoding information so that fewer data bits are required to represent a given amount of data. Compression facilitates the transmission of more data for a given amount of transmission time and circuit capacity. It also reduces the amount of memory required for data storage.

data service unit

DSU. A device designed to transmit and receive digital data on digital transmission facilities.

DDS

Dataphone Digital Service also called Digital Data System. A private line digital service for transmitting data end-to-end at speeds of 2.4, 4.8, 9.6, and 56 kbps and in some cases 19.2, 38.4, or 64 kbps. The systems can use central hub offices for obtaining test access, bridging legs of multipoint circuits, and cross connecting equipment. DDS is offered on an inter-LATA basis by AT&T and on an intra-LATA basis by the Bell operating companies.

DDS Stress Patterns 1-4

A series of test patterns designed to test DDS circuits. Each pattern is designed to stress the DDS circuit in a particular manner to assure its reliability.

DSU

See *data service unit*.

DSU loopback

A telco initiated test which loops the DSU back to the telco and is used to test the DDS circuit as well as the DSU/CSU.

DTE

Data terminal equipment. In the EIA-232C standard specification, the EIA-232C is connected between the DCE and a DTE. The main difference between the DCE and the DTE is that pins two and three are reversed.

DTE to loop rate matching

A feature designed into ADTRAN DSU/CSU products that allows slower DTE devices to communicate over 56/64 kbps digital circuits.

DTR-dialing

Data terminal ready. A control signal sent from the DTE to the DCE that indicates the DTE is powered on and ready to communicate. DTR dialing allows a DSU/CSU to dial a predetermined number when DTR goes high.

EIA-232C

A set of standards specifying various electrical and mechanical characteristics for interfaces between computers, terminals, and modems. Defines the mechanical and electrical characteristics for connecting DTE and DCE data communications devices. It defines what the interface does, circuit functions, and their corresponding connector pin assignments. The standard applies to both synchronous and asynchronous binary data transmission.

EIA-366A

An EIA interface standard for autodialing.

FCC Part 15 of Class A

Radiated and conducted emissions standards set for commercial and industrial use.

FCC Part 15 of Class B

Radiated and conducted emissions standards set for residential use.

FCC Part 68

FCC rules and regulations intended to provide protection of the telephone network from harm caused by connection of equipment to the network.

in-band

Signaling (dialing, diagnostics, management, configuration, etc.) over the same channel used for data.

ISDN

Integrated Services Digital Network. A network architecture that enables end-to-end digital connections. The network supports diverse services through integrated access arrangements and defines a limited set of standard, multipurpose interfaces for equipment vendors, network providers, and customers. Interworking with a public switched telephone network is retained.

local DTE and loop test

A test initiated by the user that loops the DSU to the central office and back. This is used to test the local DSU's DTE and local loop.

multidrop

A communications arrangement in which multiple devices share a common transmission channel, although only one may transmit at a time.

out-of-band

Signaling that is separated from the channel carrying information (voice, data, video, etc.). Typically the separation is accomplished by a filter. The signaling includes dialing and other supervisory signals.

private network tributary clocking

Clocking in which the timing is derived from the DDS loop.

private network master clocking

Clocking in which timing is derived internally from the DSU.

private network master - slaved to external clock

Clocking in which timing is slaved to the DSU's external transmit clock.

PSTN

Public switched telephone network. A direct distance dialing telephone network that is available for public use. The network is an integrated system of transmission and switching facilities, signaling processors, and associated operations support systems that is shared by customers. PSTN also is called public network, public switched network, or public telephone network.

point-to-point

A private circuit, conversation, or teleconference in which there is one person at each end, usually connected by some dedicated transmission modem.

RDL

Remote digital loopback.

remote configuration

A feature designed into ADTRAN DSU/CSU products that allow a remote DSU/CSU to be configured from a local DSU/CSU or VT 100 compatible terminal.

remote V.54 test

A diagnostic feature that allows testing of the DDS circuit by looping the remote DSU/CSU back to the local DSU/CSU.

RJ-45S

Registered jack. 8-pin connector used for data transmission over standard telephone wire. Single line, 2-wire T/R, PR/PC, programmed data, 8 position, keyed.

scrambler

A device that transposes or inverts signals, or otherwise encodes a message at the transmitter, to make it unintelligible at a receiver not equipped with an appropriately set descrambling device.

service

The provision of telecommunications to customers by a common carrier, administration, or private operating agency, using voice, data, and/or video technologies.

SNMP

Simple Network Management Protocol. A control and reporting scheme widely used to manage devices from different vendors. SNMP operates on top of the Internet protocol.

SR

Data set ready. A signal on the EIA-232 interface that indicates if communication is connected and ready to start handshaking control signals so communication can begin.

switched

In regards to DSU/CSUs, the ability to perform the functions of establishing and releasing connections on a per call basis between two or more circuits, services or communications systems. The DSU III S2W and DSU III S4W are examples of Switched 56 DSU/CSUs.

tail circuit

A feeder circuit, which may be digital or analog, that provides an access line to a digital or analog network.

U interface

A twisted-pair subscriber loop carrying an ISDN 160 kbps digital signal between the ISDN central office and the NT1 at the customer premises.

UL

Underwriters Laboratories. A laboratory established by the National Board of Fire Underwriters that tests equipment, materials, and systems that may affect insurance risks, with special reference to fire dangers and other hazards to life.

UL 1459

A UL rating that assures the connected equipment (DSU/CSU) provides protection from current overloads and power line crosses.

V.25 bis

Automatic calling and answering command set including the ability to work with async, bisync and HDLC devices. Provides a small subset of the functions of the Hayes Standard AT Command Set.

V.32 bis

Higher speed CCITT standard for full-duplex transmission on two-wire leased and dial-up lines at 4.8, 7.2, 9.6, 12, and 14.4 kbps. They do not rely on compression to achieve that high speed.

V.34

Latest high-speed CCITT standard for full-duplex transmission on two-wire leased and dial-up lines at the following rates: 2.4, 4.8, 7.2, 9.6, 12, 14.4, 16.8, 19.2, 21.6, 24, 26.4, and 28.8 kbps without compression. The maximum connection rate between two V.34 modems is 28.8 kbps. Occasionally, connections occur at 26.4, 24, and 21.6 kbps because line quality differs from one call to the next.

V.FC (V. Fast Class)

Proprietary modulation scheme developed by Rockwell International for data communication speeds up to 28.8 kbps.

VT 100

A non-intelligent terminal or terminal emulation mode used for asynchronous communications.

Index

Numerics

- 1B+D basic rate ISDN 1-4
- 2047 F-1
- 2-Wire Switched 56 1-3, F-1
- 4 F-1
- 4-Wire Switched 56 1-3
- 4-Wire switched 56 F-1
- 511 F-1

A

- All 1s or all 0s condition 1-5, 8-5
- Answer
 - Call 10-2, 10-4
- Anti-stream 6-10
 - Factory default 6-10
- AT commands 2-7, 11-1
 - Clear to send (CS) 6-9
 - DTE
 - Rate 6-2
 - Phone number 8-4
- AT&T 5ESS 8-10
- AT&T Publication 41458 F-1
- AT&T Publication 62310 F-1
- Auto DBU fail 8-6
- Automatic DBU 8-4
- Auxiliary EIA-232 3-7

B

- BERT F-2

C

- Call disconnect 10-2
- Cancel 3-2, 3-5
- Carrier detect (CD) 3-6, 6-11
- Channel service unit F-2
- Check telco 10-4
- Clear to send (CS) 3-6, 6-8
 - commands 6-9
- Clock source 5-5
- Clocking F-2
- commands
 - ta set ready (SR) 6-14
- Compression 8-8
- Configuration 3-2
 - Dial backup 8-1
 - Local 4-1
 - Methods 2-7
 - Network options 5-1
 - Test options 7-1
- Configuration DTE options 6-1
- Configuration local 2-10
- Configuration remote 2-11
- Connector
 - EIA-232 D-1
- Connector type 6-4
 - Factory default 6-4
- Control port F-2
- CPE F-2
- CS F-3
- CSU F-3
- CSU loopback F-3
- CTS F-3
- Customer service 2-1

D

- Data buffering E-2
- Data compression F-3
- Data format 6-5
 - Factory default 6-5
- Data invert option 6-3
- Data mode 10-3
- Data service unit F-3
- Data set ready (SR) 6-13, 10-4
 - commands 6-14
 - Factory default 6-13
- Data terminal ready (TR) 6-12, 10-4
 - Factory default 6-12
- DATAPATH 1-1, 1-3
- DBU answer test 7-4
- DBU connection 11-23
- DBU line in RDL 10-3
- DBU online test 9-2
- DBU options
 - 2-wire and 4-wire 8-8
 - All models 8-4
 - ISDN 8-10
 - V.32 bis 8-8
- DBU passcode 8-10
- DBU status 10-2
- DDS F-3
- DDS network status 10-4
- DDS stress patterns 1-4 F-3
- Diagnostics E-2
- Dial 3-2
- Dial backup 9-2
 - atus information 10-2
 - Configuration 8-1
 - de 9-1
 - ISDN 8-3
 - Mode
 - Status 10-2
- Dial options 4-1, 9-1
- Dial up operation B-1
- Dialing 10-2
- Digital data service (DDS) 1-1, 1-2, 1-4, 2-2, 5-5, 9-1
- Down arrow 3-2
- DSU F-4
- DSU loopback F-4
- DSU status 10-3
- DSU to modem interconnect C-1
- DTE F-4
- DTE & loop (LL) 11-10
- DTE command option 6-6
- DTE connectors 3-6
- DTE control leads 10-4
- DTE data connection 2-3
- DTE interface 3-7
 - rameters 4-1
- DTE only 11-14
- DTE options 4-1
- DTE rate 6-1
 - commands 6-2
 - Factory default 6-1
 - Same as the network 6-1
- DTE to loop rate matching F-4
- DTR-dialing F-4
- DU DBU status 10-2

E

- EIA local loopback (LLB) 7-3
- EIA remote loopback (RLB) 7-3
- EIA-232 connector D-1
- EIA-232 interface 1-1
- EIA-232C F-4
- EIA-366A F-4
- Enter 3-2, 3-4
- Error control 8-8
- Exit test 11-3
- External clock 6-7, D-1

F

- Fail timer 8-6
- FCC Part 15 of Class A F-4

FCC Part 15 of Class B F-5

FCC Part 68 F-5

Flow control

 AT commands 8-8

Function keys 3-2

G

Going to DBU 10-2, 10-4

H

Hang up 9-2

I

Idle 10-2

In dial backup 10-2, 10-4

In-band F-5

Incoming call 10-2

Installation 2-1

INV 2-10

INVBL 2-10

INVBM 2-10

INVCU 2-10

INVPS 2-10

INVPV 2-10

ISDN F-5

 DBU status 10-2

 Dial backup 8-3

L

LCD

 Description 3-6

LCD window 3-4

LED

 Description 3-5

line 1 connector 2-2

line 2 connector 2-2

LL test from telco 10-4

Local configuration 4-1

Local DTE and loop test F-5

Local loopback 10-4, 11-1

Local unit

 Test 11-8

Loop is normal 10-4

Loop only (RT) 11-12

Loop rate 3-3, 5-3

Loss of sealing current 1-4

M

Main menu 3-1, 3-5, 11-3

Manual command 4-1, 12-1

Menu navigation 3-1

Modem tail circuit

 plication C-1

Multidrop F-5

N

National ISDN1 8-10

Network

 interface connection 2-2

 terface parameters 4-1

Network address 5-4

Network options 3-3, 4-1, 5-1

Network rate 10-1

Network type 8-8

No DBU installed - DBU status 10-2

No receive (RX) signal 1-5, 8-5, 10-3

No sealing current 8-5

No wink from CO 10-3

Not installed 10-3

NT DMS-100 8-10

Number to dial 8-4

Numeric keypad 3-4

O

OOS/OOF from net 10-3

OOS/OOF from telco 10-4

Open loop 10-3, 10-4

Operation 3-1, 11-1

Originate 8-5
Originate/answer 8-5
Out of service (OOS)
 gnal 1-4
Out-of-band F-5

P

Phone number 8-3
 AT command 8-4
Pin assignments
 Line 1 connector 2-2
 line 2 connector 2-3
Point-to-point F-6
Point-to-point operation 6-3, B-1
Pon assignments
 Primary V.35 connector 2-6
Power cord 3-7
Power switch 3-7
Power up 2-2
Primary EIA-232 3-7
Primary V.35 3-7
Private network master
 aved to external clock F-6
Private network master clocking F-5
Private network tributary clocking F-5
PSTN F-6

Q

Quick 3-5

R

RDL F-6
Rear panel 3-6
Receipt inspection 2-1
Receive data 3-6
Redial counter 8-6
Remote command 2-11

Remote configuration F-6
 able/disable 5-4
Remote digital loopback (RDL) 7-2
Remote loopback 10-4, 11-1
Remote V.54 test F-6
Restore timer 8-5
return material authorization (RMA) xi
RJ-45S F-6

S

Scrambler F-6
Scrambler on option 6-3
Scrambler on/off
 Factory default 6-3
Secondary channel 3-6, 6-14
 Connection 2-6
 rvices 3-7
Secondary rate 6-14
 Factory default 6-14
Self test 11-20
Service F-7
Shift 3-5
SNMP F-7
SR F-7
Status 3-1, 10-1
 DDS network 10-4
 Dial backup mode 10-2
Stay on leased 9-2
Stay on line 9-3
SW56 DBU status 10-2
Switch type 8-10
Switched F-7
Synchronous operation 11-1

T

Tail circuit F-7
Telco jack 3-6
Test 3-1, 10-4
 DTE only 11-14

- Self 11-20
- Test pattern 11-18
- Test from telco 10-3
- Test mode manual 3-6
- Test options 4-1
 - Configuration 7-1
- Test pattern 11-18
- Test timeout 7-2
- Transmit clock 6-7, D-1
- Transmit data 3-6

U

- U interface F-7
- UL F-7
- UL 1459 F-7
- Unit dialing options 4-1
- Unit in test 10-3
- Unit test options 4-1
- Up arrow 3-2, 3-5

V

- V.25 bis F-8
- V.25 bis commands 2-8, 11-1
 - Asynchronous option 2-9
 - Bi-sync option 2-9
 - SDLC option 2-9
- V.32 bis F-8
- V.32 bis backup option 1-3
- V.32 bis/42 bis 1-1, 1-3
- V.32 DBU status 10-2
- V.34 1-1, 1-4, 2-2, 8-8, F-8
 - DBU status 10-2
- V.35 connector 2-3
- V.FC (V. Fast Class) F-8
- VALA 2-10
- VT 100 F-8

W

- Wait to redial 8-6
- Waiting for call 10-3, 10-4
- When out of service (OOS) 8-5

Product Support Information

Presales Inquiries and Applications Support

Please contact your local distributor, ADTRAN Applications Engineering, or ADTRAN Sales:

Applications Engineering (800) 615-1176

Sales (800) 827-0807

Post-Sale Support

Please contact your local distributor first. If your local distributor cannot help, please contact ADTRAN Technical Support and have the unit serial number available.

Technical Support (888) 4ADTRAN

Repair and Return

If ADTRAN Technical Support determines that a repair is needed, Technical Support will coordinate with the Customer and Product Service (CaPS) department to issue an RMA number. For information regarding equipment currently in house or possible fees associated with repair, contact CaPS directly at the following number:

CaPS Department (256) 963-8722

Identify the RMA number clearly on the package (below address), and return to the following address:

ADTRAN, Inc.
CaPS Department
6767 Old Madison Pike
Progress Center
Building #6, Suite 690
Huntsville, AL 35807

RMA # _____

