

NetVanta 1560-48-740W

48-port Managed GbE 740W PoE+ Switch

P/N: 17108148PF2

Quick Start

Overview

This quick start describes how to install, configure, and troubleshoot the NetVanta 1560-48-740W, 48-port Managed GbE 740W PoE+ Switch. Figures 1 and 2 show the Front and Rear Panel layouts of the switch.

- “Installing the Switch” on page 1
- “Initially Configuring the Switch” on page 4
- “Power Over Ethernet (PoE)” on page 5
- “Understanding the Status LEDs” on page 6
- “Using the MODE Button” on page 7
- “Troubleshooting the Switch” on page 7

Figure 1. Front Panel Layout

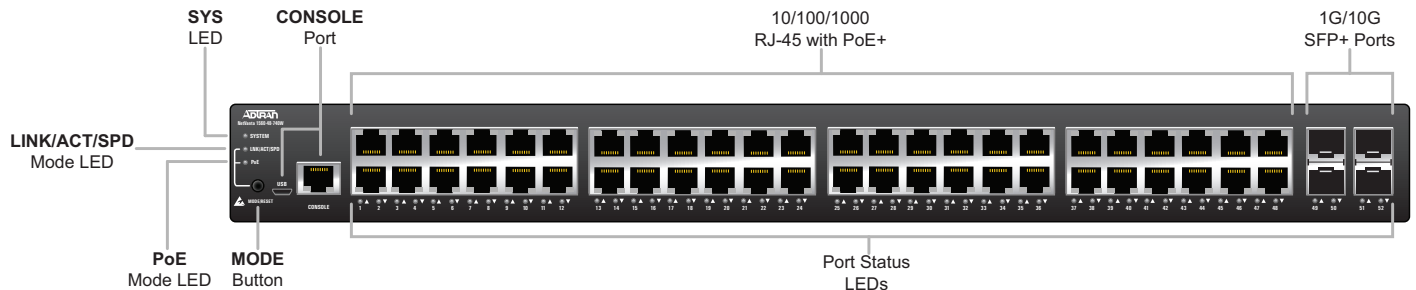

Figure 2. Rear Panel Layout



Installing the Switch

Package Contents

- NetVanta 1560-48-740W switch
- AC power cord
- DB-9 to RJ-45 cable
- Micro-USB to USB cable
- Four adhesive rubber feet
- Mounting kit (two brackets and eight screws)
- Quick Start



WARNING!

The NetVanta 1560-48-740W is intended for indoor use only. Ethernet, PoE cables, and attached equipment are intended for use within the same building with equipotential bonding, and not intended to be placed in separate buildings or structures. Failure to deploy as described could result in permanent damage from lightning or other electrical events and voids the warranty.

Installation Overview

To install the switch, you will need to do the following:

1. Mount the switch
2. Connect AC Power
3. Install SFP+ Modules

Installation Steps

To install the NetVanta 1560-48-740W switch, complete the following steps:

Mount the Switch

The switch can be mounted in a 19-inch rack, or on a desk or shelf.

Mounting in a 19-inch Rack

To mount the switch into a 19-inch rack, complete the following steps.

1. Attach the mounting brackets to both sides of the chassis. Insert the provided screws and tighten them with a screwdriver to secure the brackets.

Figure 3. Attaching Brackets to the Switch

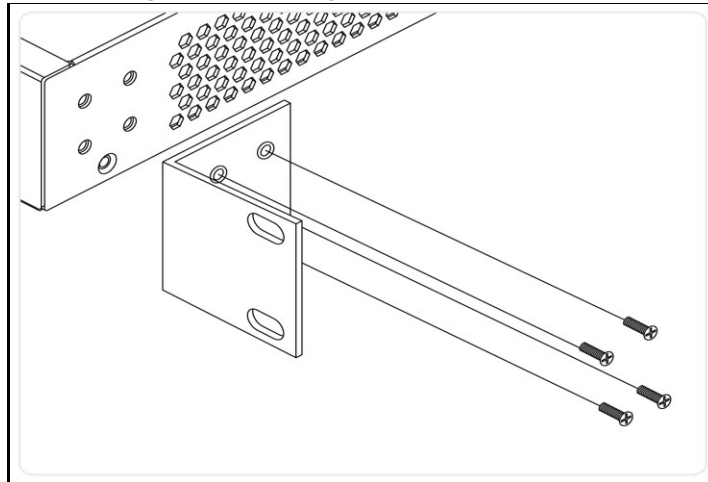

2. Place the switch on a rack shelf in the rack. Push it in until the oval holes in the brackets align with the mounting holes in the rack posts.
3. Secure the brackets to the posts by inserting rack screws and tightening them with an appropriate screwdriver. Rack mount brackets are a default accessory with the unit; spare brackets can be ordered through ADTRAN, part number: 1700519F1.

Figure 4. Attaching Brackets to the Rack Post

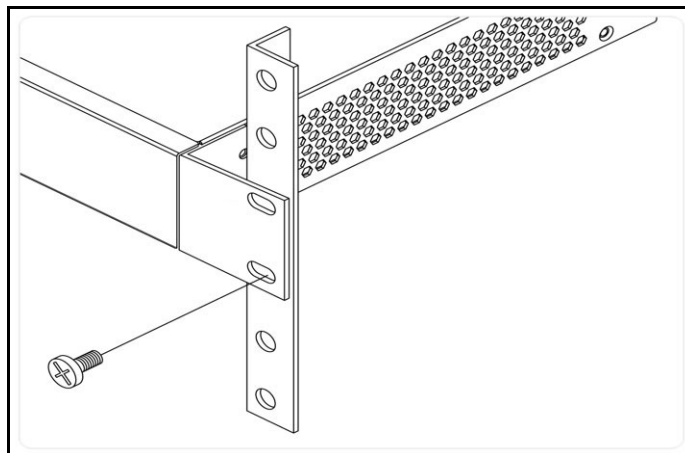

Mounting on a Desk or Shelf

To mount the switch on a desk or shelf, complete the following steps.

1. Verify that the desk or shelf is sturdy enough to support the switch.
2. Attach the four adhesive rubber feet to the bottom of the switch.

Figure 5. Attaching the Rubber Feet

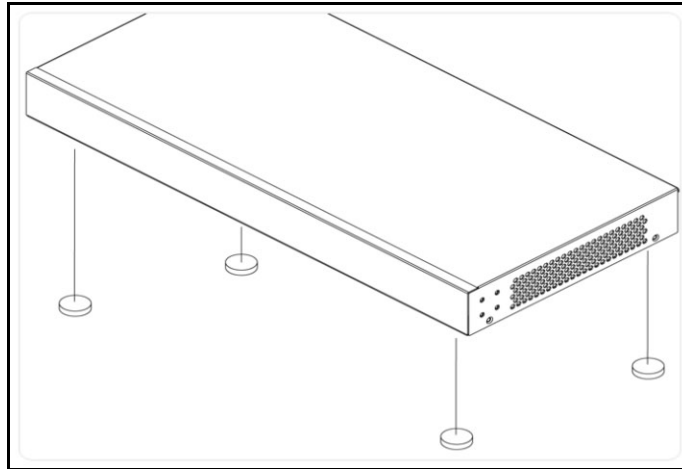

CAUTION!

Desk or shelf mounting of the equipment should be such that the amount of air flow required for safe operation of the equipment is not compromised. Allow 1-inch clearance on the top and sides of the unit for sufficient air flow.

Connect AC Power

To connect the AC power cord to the switch, complete the following steps.

1. Connect the AC power cord to the AC power receptacle on the rear panel of the switch.
2. Connect the other end of the AC power cord to a properly grounded AC power outlet.
3. Confirm that the power is connected properly. The **SYSTEM LED** should be **ON** (see ["SYSTEM Status LED"](#)).

Figure 6. Connecting the AC Power Cord

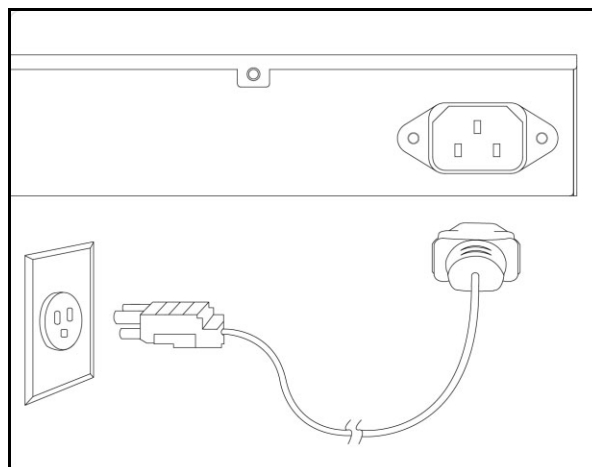

Install SFP+ Modules

You can install or remove a mini-GBIC SFP+ module from a SFP+ port without having to power off the switch. To install an SFP+ module, complete the following steps.

1. Insert the module into the appropriate SFP+ port.

2. Press firmly to ensure that the module seats properly into the connector.

Figure 7. Installing an SFP+ Module into an SFP+ Port

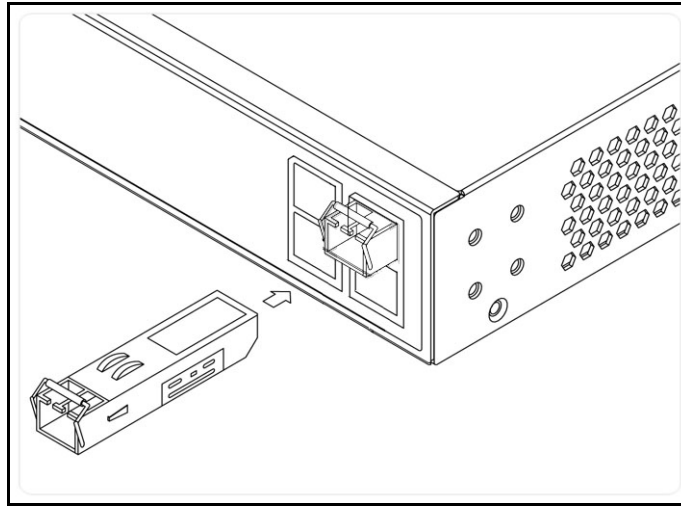

i NOTE

This product is intended for use with a Class 1 Laser module that complies with FDA 21 CFR 1040.10, 1040.11 and IEC 60825-1. For continued compliance with the above standards, only approved Class 1 Laser modules from an ADTRAN approved vendor list (located online at www.adtran.com) should be installed in this product. ADTRAN cannot certify system integrity with other laser modules.

Initially Configuring the Switch

The Switch can be configured by two methods:

- Web based Graphical User Interface (GUI)
- Command Line Interface (CLI)

Initial Switch Configuration Using a Web Browser

After powering up the switch for the first time, you can perform the initial switch configuration using a web browser.

To begin with the initial configuration stage, you need to reconfigure your PC's IP address and subnet mask to make sure the PC can communicate with the switch. After changing PC's IP address (for example, 10.10.10.250), then you can access the web interface of the switch using the switch's default IP address as shown below.

i NOTE

The factory default IP address of the switch is **10.10.10.1** and the subnet mask is **255.255.255.0**. If the switch is connected to a Dynamic Host Control Protocol (DHCP) server, the server assigns the switch an IP address and the default **10.10.10.1** IP address is not configured. The DHCP server also assigns your PC the correct IP address to allow a connection on the same subnet as the switch.

Initial Switch Configuration Procedure

To initially configure the switch, complete the following steps.

1. Power up the PC that you will use for the initial configuration. Please make sure the PC has the Ethernet RJ-45 connector to be connected to the switch via standard Ethernet LAN cable. If the switch is connected to a DHCP server, skip to Step 3.
2. Reconfigure the PC's IP address and subnet mask as below, so that it can communicate with the switch. For example, the method to change the PC's IP address for a PC running Windows® 7/8.x/10 is as follows:
 - a. Type **network and sharing** into the Search box in the Start Menu.
 - b. Select **Network and Sharing Center**.
 - c. Select **Change adapter settings** on the left of PC screen.

i NOTE

Users can also skip Steps 1-2, by pressing **WinKey+R** and typing the **ncpa.cpl** command to get to Step 4 directly.

- Right-click on your **local adapter** and select **Properties**.
- In the **Local Area Connection Properties** menu, highlight **Internet Protocol Version 4 (TCP/IPv4)**. Then, select the **Properties** button.



NOTE

Be sure to record all your PC's current IP settings to be able to restore them later.

- Select the radio button **Use the following IP address** and enter in the IP address for the PC (e.g., any IP address not in use, and in between 10.10.10.2 and 10.10.10.254), subnet mask (e.g., 255.255.255.0).
 - Select **OK** to change the PC's IP address.
3. Power up the switch to be initially configured, and wait until it has finished its start-up processes.
 4. Connect the PC to any port on the switch using a standard Ethernet cable, and check the port LED on the switch to make sure the link status of the PC is OK.
 5. Run your web browser on the PC; enter either the DHCP-assigned or factory default IP address to access the switch's web interface. If your PC is configured correctly, you will see the login page of the switch requesting your username and password. In some browsers, the information needed may be requested in a new window.

If you do not see the login page, perform the following steps:

- a. Refresh the web page.
 - b. Check to see if there is an IP conflict issue.
 - c. Clean browser cookies and temporary Internet files.
 - d. Check your PC settings again and repeat Step 2.
6. Enter the factory default username in the login page. Select **Login** to log into the switch.



NOTE

The factory default username of the switch is **admin**. The factory default password is **password**.

Initial Switch Configuration Using CLI

The CLI can be accessed using any one of the two console ports (USB & RJ45) available in the switch. To establish the connection to the console port, the following are needed:

- PC with VT100 terminal emulation software
- Micro USB to USB cable or a DB-9 to RJ45 Serial Cable (the cables are provided along with the unit)



NOTE

There are many terminal emulation applications available on the web. PuTTY, SecureCRT, and HyperTerminal are a few examples.

Complete the following steps:

1. Connect a Micro USB cable to the micro USB CONSOLE port or connect a DB-9 to RJ-45 serial cable to the RJ-45 CONSOLE port.
2. If using a Micro USB cable, connect the other end of the USB cable to a USB port on the PC. If using an RJ-45 serial cable, connect the other end to the serial terminal on the PC.
3. If using the Micro USB cable to connect the switch, check if the USB drivers are automatically installed in the PC. If not install manually.
4. Open a VT100 terminal session using the following settings: 115200 baud; 8 data bits; no parity bits; 1 stop bit; and no flow control. Press <Enter> to activate the CLI.
5. Login with the default user name (**admin**) and password (**password**).

Power Over Ethernet (PoE)

The switch provides the PoE on the 48 Ethernet ports shown in [Figure 1](#). PoE provides the ability to detect attached Powered Devices (PDs), and deliver power to the PD via Ethernet cabling. The switch is fully compliant with the IEEE 802.3af PoE and IEEE 802.3at PoE+ standards. By default, the PoE switch discovers and provides power to IEEE-compliant PDs, it also supports legacy PDs. The total PoE budget for the switch is 740W. Each port can provide a maximum of 30W in compliance to the IEEE 802.3at PoE+ standard. All 48 ports cannot have 30W PD devices as this exceeds the PoE budget of the switch; a combination of few 30W PDs and low power PDs can be used as long as the sum of load is less than 740W.

Understanding the Status LEDs

The LEDs on the front panel provide you with switch status checking and monitoring. The following section describes the three types of LEDs.

SYSTEM Status LED

The SYSTEM Status LED indicates if the switch is powered up correctly or if a system alarm has been triggered for troubleshooting.

LED	Color	State	Description
SYSTEM	○	Off	The switch is not receiving power.
	●	On	The switch is powered ON correctly.
	●	On	An abnormal state, such as exceeding operating temperature range, has been detected in the switch.

LINK/ACT/SPD Mode LED

The LINK/ACT/SPD Mode LED indicates the port status LEDs are displaying in link/act/speed mode.

LED	Color	State	Description
LINK/ACT/LED	●	On	The port status LEDs are displaying link status, network activity, and the speed of each port.

PoE Mode LED

The PoE Mode LED indicates the port status LEDs are displaying in PoE mode.

LED	Color	State	Description
PoE	●	On	The RJ-45 port status LEDs are displaying the PoE powering status of each port.

Port Status LEDs

The Port Status LEDs indicate the current status of each port in either Link/Act/Speed mode or PoE mode. By pressing the **MODE** button for less than two seconds, you can change LED modes from **LINK/ACT/SPD** mode to **PoE** mode, to check the port status in each mode.

When LINK/ACT/SPD Mode LED Is Lit

When the LINK/ACT/SPD Mode LED is lit, the link/act/spd status is indicated by the LED behavior.

LED	Color	State	Description
RJ-45 Ports	●	On	The port is enabled and established a link to connected device, and the connection speed is 1000 Mbps.
		Flashing	The port is transmitting/receiving packets, and the connection speed is 1000 Mbps.
	●	On	The port is enabled and established a link to connected device, and the connection speed is 10/100 Mbps.
		Flashing	The port is transmitting/receiving packets, and the connection speed is 10/100 Mbps.
	○	Off	The port has no active network cable connected or has not established a link to connected device. Otherwise, the port may have been disabled through the switch user interface.
	SFP+ Ports	●	On
Flashing			The port is transmitting/receiving packets, and the connection speed is 10 Gbps.
●		On	The port is enabled, has established a link to connected device, and the connection speed is 1 Gbps.
		Flashing	The port is transmitting/receiving packets, and the connection speed is 1 Gbps.
○		Off	The port has no active network cable connected or has not established a link to connected device. Otherwise, the port may have been disabled through the switch user interface.

When PoE Mode LED Is Lit

When the PoE Mode LED is lit, the PoE status is indicated by the LED behavior.

LED	Color	State	Description
RJ-45 Ports	●	On	The port is enabled and supplying power to a connected device.
	●	On	An abnormal state, such as an overload status, has been detected in the switch.
	○	Off	The port has no active network cable connected, or it is not connected to a PoE powered device. Otherwise, the port may have been disabled through the switch user interface.

Using the MODE Button

By pressing the **MODE** button for certain period of time, you can perform the following tasks:

- Change Port Status LED Mode
To read the port status Link/Act/Speed or PoE modes.
- Reset the Switch
To reboot and restore the switch to the previous configuration settings saved.
- Restore the Switch to Factory Defaults
To restore the original factory default settings to the switch.



NOTE

As seen in the table below, you can easily judge which task is being performed by reading the LED behaviors while pressing and holding the **MODE** button. **Once the correct LED behaviors are displayed, release the button.**

Task	Press for...	System LED Behavior	Port Status LED Behavior
Change LED Mode	0 ~ 2 seconds	Solid Green	LED status will change according to the mode selected.
Reset the Switch	2 ~ 7 seconds	Flashing Green	All LEDs are OFF.
Restore to Factory Defaults	7 ~ 12 seconds	Flashing Green	All LEDs are ON.

Troubleshooting the Switch

The following table provides information to easily troubleshoot problems by taking actions based on the suggested solutions.

Symptoms	Possible Causes	Suggested Solutions
System LED is OFF	The switch is not receiving power.	<ol style="list-style-type: none"> 1. Check if correct power cord is connected firmly to the switch and to the AC outlet socket. 2. Cycle the power on the switch by unplugging and plugging the power cord back into the switch. 3. If the LED is still off, try plugging the power cord into different AC outlet.
System LED is RED	An abnormal state has been detected by the switch.	Check the system log within the switch from web user interface to understand the abnormal state (e.g., exceeding operating temperature range) and take corresponding actions to resolve.
Port Status LED is OFF when the LINK/ACT/SPD LED is LIT	The port is not connected or the connection is not functioning.	<ol style="list-style-type: none"> 1. Check if the cable connector plug is firmly inserted and locked into the port at both the switch and the connected device. 2. Make sure the connected device is up and running correctly. 3. If the symptom still exists, try using a different cable or different port, in order to identify if it is related to the cable or specific port. 4. Check if the port is disabled in the configuration settings via web user interface.
Port Status LED is OFF when the PoE LED is LIT	The port is not supplying power.	<ol style="list-style-type: none"> 1. Check if the cable connector plug is firmly inserted and locked into the port at both the switch and the connected device. 2. Make sure the correct Ethernet cables were used. 3. If the symptom still exists, try using a different cable or different port, in order to identify if it is related to the cable or specific port. 4. Check if the port is disabled in the configuration settings via web user interface.



Product Specifications

Compliance

- This device complies with Part 15 of the FCC rules. Operation is subject to the following two conditions:
 - 1. This device may not cause harmful interference.
 - 2. This device must accept any interference received, including interference that may cause undesired operation.
- Changes or modifications not expressly approved by ADTRAN could void the user's authority to operate this equipment.



NOTE

This equipment has been tested and found to comply with the limits for a Class A digital device, pursuant to part 15 of the FCC Rules. These limits are designed to provide reasonable protection against harmful interference when the equipment is operated in a commercial environment. This equipment generates, uses, and can radiate radio frequency energy and, if not installed and used in accordance with the instruction manual, may cause harmful interference to radio communications. Operation of this equipment in a residential area is likely to cause harmful interference in which case the user will be required to correct the interference at his own expense. CAN ICES-3 (A)/NMB-3(A)

- NRTL Listed to UL/CSA 60950-1 and 62368-1
- Meets IEC 62368-1, EN 62368-1, and AS/NZS 62368.1 Safety Requirements
- IEEE 802.3at PoE+

Environment

- Operating Temperature: 32°F to 113°F (0°C to 45°C)
- Storage Temperature: -40°F to 158°F (-40°C to 70°C)
- Relative Humidity: 10 to 95 percent, non-condensing

Electrical

- Power Supply: 100 to 240 VAC, 50-60 Hz, 11A

Documentation for ADTRAN Network Solutions products is available for viewing and download directly from the ADTRAN Support Community website.

Go to: <https://supportcommunity.adtran.com>

ADTRAN offers training courses on our products, including customized training and courses taught at our facilities or at customer sites.

For inquiries, go to: <http://adtran.com/training>

The following documents and resources provide additional information for this product.

[Configuring the CLI in ASE](#)
[Configuring QoS in ASE](#)
[Configuring Layer 2 Services in ASE](#)
[Configuring PoE in ASE](#)
[Configuring DHCP in ASE](#)
[Configuring MRP and MVRP in ASE](#)
[ASE Command Reference Guide](#)

Warranty: ADTRAN will replace or repair this product within the warranty period if it does not meet its published specifications or fails while in service. Warranty information can be found online at www.adtran.com/warranty.

Trademarks: Brand names and product names included in this document are trademarks, registered trademarks, or trade names of their respective holders.

Copyright © 2020 ADTRAN, Inc. All Rights Reserved.



CAUTION!
SUBJECT TO ELECTROSTATIC DAMAGE
OR DECREASE IN RELIABILITY
HANDLING PRECAUTIONS REQUIRED

ADTRAN CUSTOMER CARE:

From within the U.S. 1.888.423.8726

From outside the U.S. +1 256.963.8716

PRICING AND AVAILABILITY 1.800.827.0807



* 6 1 7 1 0 8 1 4 8 P F 2 - 1 3 0 *