

Model 5260 Cable Simulator

SECTION 1

1.0	Introduction	2
1.1	Equipment Supplied	2
1.2	Warranty	2

1.0 INTRODUCTION

The Model 5260 is a small, lightweight, portable cable simulator ideally suited to both engineering and manufacturing testing of ISDN, DDS, or similar products. Using passive distributed RLC components, it is capable of modeling a single gauge of PIC cable with a maximum length of 60,000 feet at 100 kHz bandwidth or 20,000 feet at 300 kHz bandwidth. The different lengths are controlled via front panel switches with mechanical indicators for easy setup. The unit has rear panel terminals for the wiring of bridged taps between each selectable wire section and at the inputs and outputs. Multiple units can be easily wired into simple or complex bridged tap configurations and chained to create lengths of varying gauge.

An optional remote control card can be added to the basic unit to provide RS-232-C and IEEE-488 remote control capabilities.

1.1 EQUIPMENT SUPPLIED

The Model 5260 is supplied with the following items:

- Basic Cable Simulator for Selected Gauge
- Product Manual with Users Guide
- Spare Fuses (4)

Optional equipment supplied when ordered include:

- Internal Option Card for Remote Control
- Power Transformer for Remote Control Option
- 19-Inch Rack Mount Kit

1.2 WARRANTY

Processing Telecom Technologies warrants each Model 5260 against defects in material and workmanship for a period of one year from the date the Model 5260 was shipped to the customer. If, at any time during the warranty period, the Model 5260 should malfunction, PTT will repair or, at PTT's option, replace the unit free of charge.

The remedies listed herein are the users sole and exclusive remedies. PTT shall not be liable for any indirect, direct, incidental, or consequential damages. Owner must return the unit to the factory; shipping prepaid, insured, and packaged to best commercial standard for electronic equipment. PTT will pay shipping charges for delivery on return. The customer is responsible for mode and cost of shipping to PTT.

Warranty does not apply if the unit has been damaged by accident, misuse, or as a result of service or modification by other than PTT personnel.

When returning a 5260 for warranty or repair work, a Return Material Authorization (RMA) number must be obtained from PTT customer service at the address and phone number below.

Customer Service Manager
 Processing Telecom Technologies
 4955 Corporate Drive
 Huntsville, Alabama 35805
 Telephone: (205) 837-7880
 FAX: (205) 722-8751

SECTION 2
OPERATION OF THE MODEL 5260

2.0 Front Panel Operation2
 Figure 2.1 Model 5260 Front Panel (earlier model)2
 Figure 2.2 Model 5260 Front Panel (latest model).....2

2.1 The Wire Select Buttons2
 Figure 2.3 Wire Select Buttons2

2.2 The 2-Wire/4-Wire Button.....2
 Figure 2.4 2-Wire/4-Wire Buttons3
 Figure 2.5 A/B Crossover3

2.3 Connecting User Equipment to the Model 52603
 2.3.1 Option Switches.....3
 Figure 2.6 Model 5260 Main Board Switch Settings4

2.4 Rear Panel Connectors.....4
 Figure 2.7 Model 5260 Rear Panel5

2.4.1 Terminal Strip.....4
 Figure 2.8 2-Wire Connections5
 Figure 2.9 4-Wire Connections5

2.4.2 Remote Control Ports4

2.4.3 AC Adapter Connector4

2.0 FRONT PANEL OPERATION

The 5260 front panel is shown in **Figures 2.1 and 2.2**. **Figure 2.1** is a depiction of earlier 5260 models. The block diagram oriented front panel on the 5260 makes manual setup and operation simple and easy. The use of large push-buttons makes configuration of the unit easy. Yellow indicator flags on each button provide an immediate visible indication of configuration information.

2.1 THE WIRE SELECT BUTTONS

The Wire Select buttons provide access to eight different wire sections of varying length. These sections can be selected in any combination to give the desired total length. The sections available are 500 feet, 1000 feet, 1500 feet, 2000 feet, 5000 feet, 10,000 feet, and two sections of 20,000 feet each. All the lengths are operable up to 300 kHz bandwidth except the two 20,000 feet sections which only operate up to 100 kHz bandwidth. The Wire Select buttons can be identified on the 5260 front panel as shown in **Figure 2.3**.

2.2 THE 2-WIRE/4-WIRE BUTTON

Figure 2.4 is an illustration of the Model 5260 front panel identifying the 2-Wire/4-Wire button. To select 2-Wire operation, press the button; a yellow flag will be visible inside. When the button is not depressed, 4-Wire operation is selected. The signal pairs are crossed over in 4-Wire operation, as illustrated in **Figure 2.5**.

Important

The 5260 provides simulated wire only in the pair 1 input signal path. When 4-Wire operation is selected, the pair 2 signal path is always set to zero length.

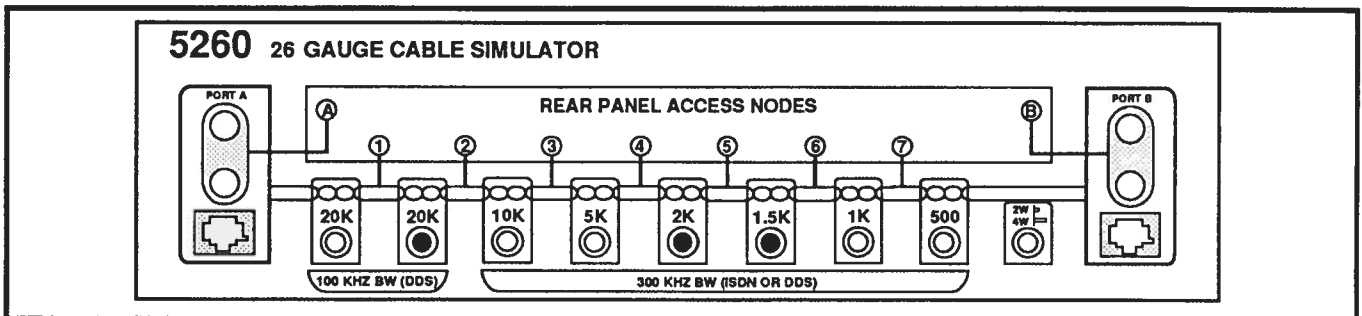

FIGURE 2.1

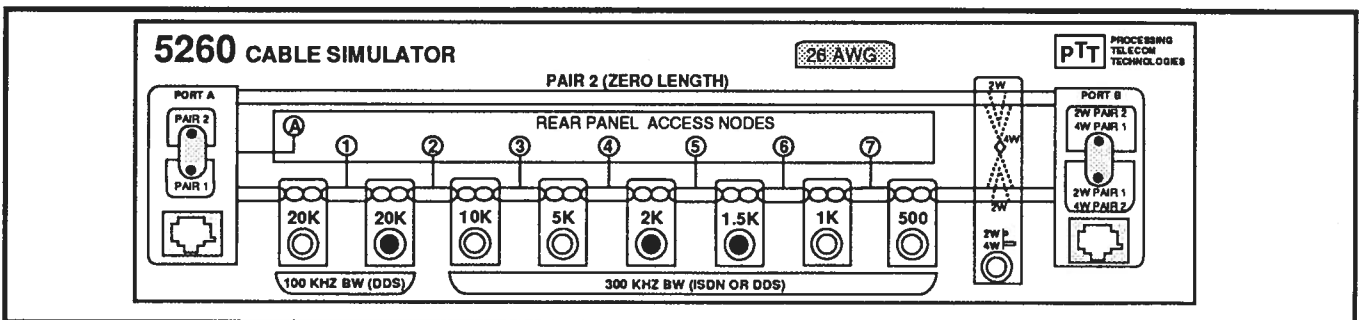

FIGURE 2.2

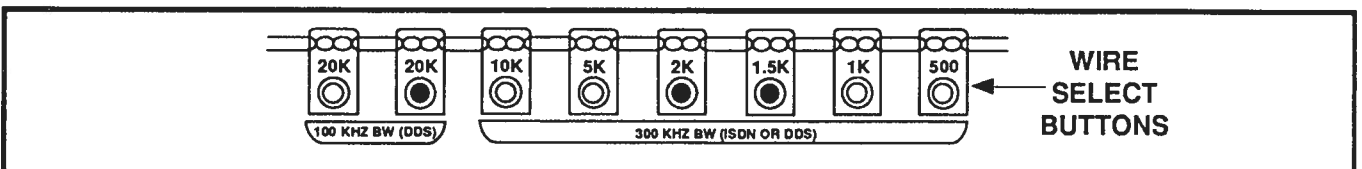

FIGURE 2.3

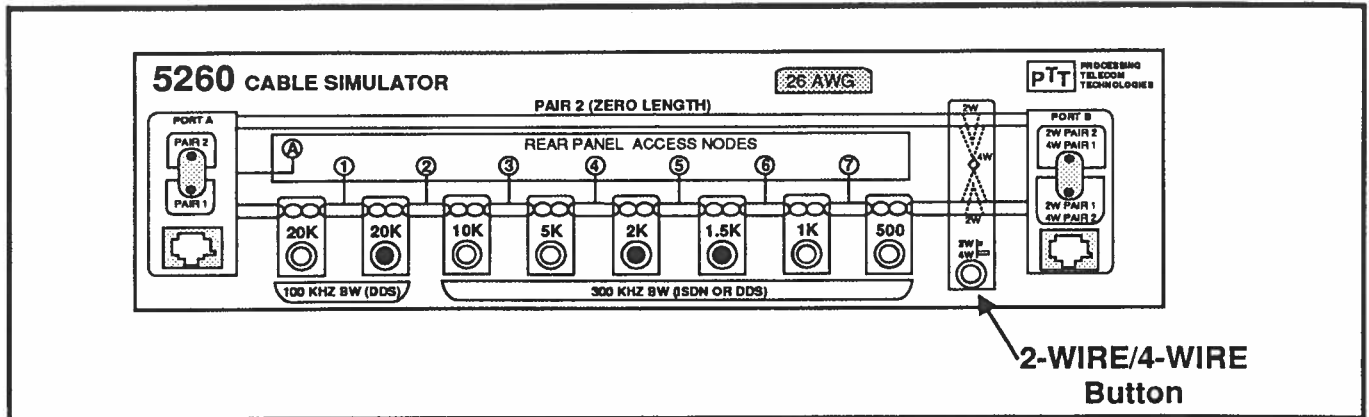

FIGURE 2.4

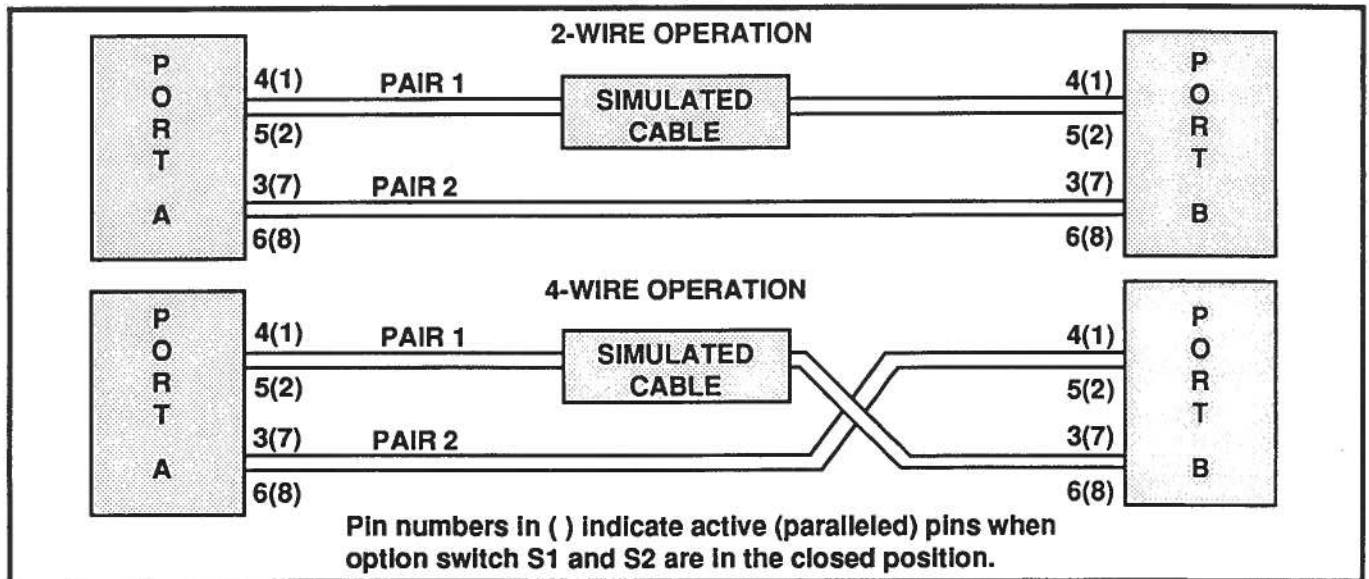

FIGURE 2.5

2.3 CONNECTING USER EQUIPMENT TO THE MODEL 5260

User equipment can be connected via Model 5260 front or rear panel jacks. Standard RJ-45S and dual Bantam jacks are provided on the front panel for connection to the pair 1 and 2 signal paths. Either jack may be used in 2-Wire and 4-Wire operation.

Note: Instead of Bantam jacks, a dual binding post provided for attachment of two wires, supporting only 2-Wire operation on earlier models of the 5260.

A terminal strip located on the rear panel of the 5260 provides for connection to the signal path nodes (labeled 1 through 7 on the front panel), as well as the pair 1 and 2 inputs and outputs (labeled Port A and Port B on the front panel).

All jacks are connected in parallel and are fully protected against over-voltage and over-current. For more information on the rear panel connectors, refer to Section 2.4.

2.3.1 Option Switches

There are two option switches located on the Model 5260 main board labeled S1 and S2 which connect pair 1 and pair 2 signal paths with Port A and Port B connector pins (see Figure 2.6). Setting all of the switches to the On or Closed position provides for the following pins to be paralleled on the Port A and Port B connector respectively:

- Pins 1 and 4
- Pins 2 and 5
- Pins 3 and 7
- Pins 6 and 8

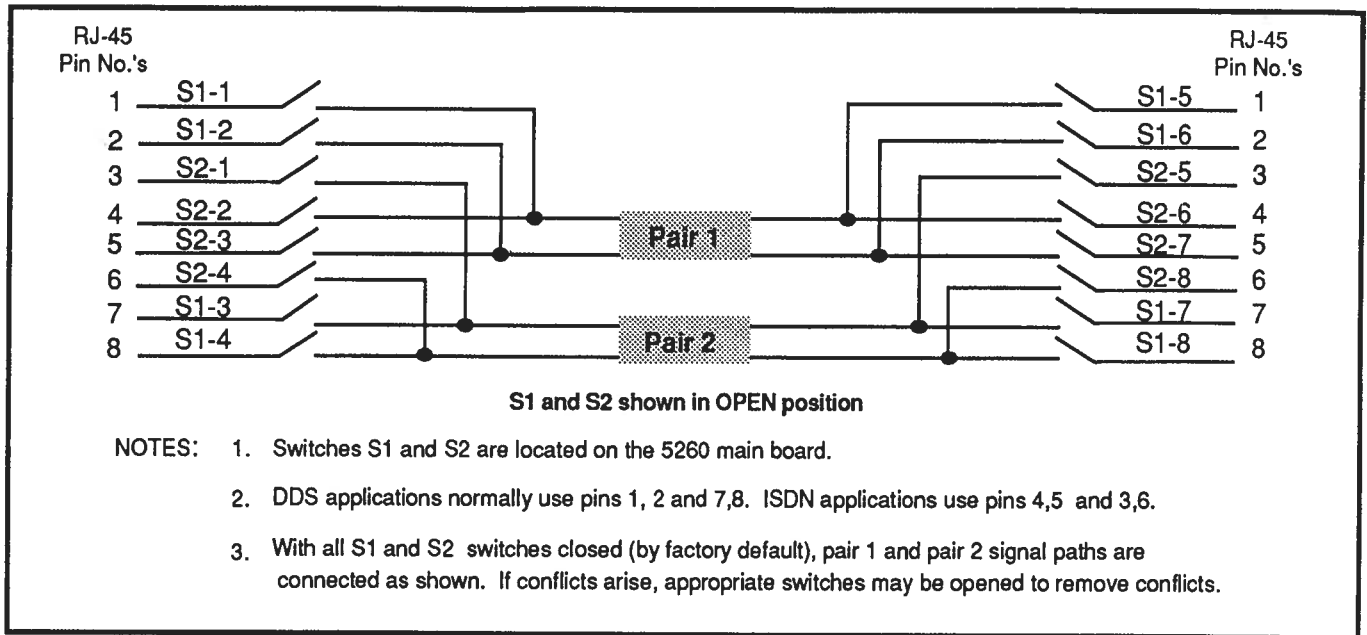

FIGURE 2.6

If conflicts exist between any of the above paralleled pins, the appropriate switch position can be turned **Off** or **Open** to disconnect those particular pins from pair 1 and pair 2 signal paths.

2.4 REAR PANEL CONNECTORS

In addition to the front panel connectors used to connect user equipment to the Model 5260, there are several other connectors located on the rear panel, as shown in **Figure 2.7**. The terminal strip connector provides secondary connection points along the signal paths while the RS-232 and IEEE-488 connectors support remote control operation.

Note: Remote control is available only with option card installed, see Figure 2.9.

2.4.1 Terminal Strip

Connection to the Port A and B signal paths, or any of the seven numbered nodes along the simulated wire paths is provided for by the rear panel terminal strip. The rear panel pair 1 and 2 terminals are connected in parallel with the front panel RJ-45S and Bantam jacks. The seven node points available on the rear panel terminal strip can be used for connecting bridged taps along the simulated wire path or monitoring signals along the signal path. Details on how to connect user equipment during 2- or 4-Wire operation is shown in **Figures 2.8** and **2.9**.

2.4.2 Remote Control (Optional)

The RS-232-C and IEEE-488 remote control ports are located on the upper part of the rear panel. The RS-232-C serial data rate, character size, parity and stop bits along with the IEEE-488 device address can be programmed via internal dip switches. See **Section 3.4** for more information.

Note: Remote control connectors are available only if unit is equipped with an option card.

2.4.3 AC Adapter Connector

The connector for the supplied AC adapter is in the upper left hand corner of the rear panel. When power is supplied to this connector, the unit is powered up. A standard size barrel type connector is used so any adapter which meets the voltage and current requirements can be used. The unit requires 9 VDC with a current rating of at least 1.0 amps.

CAUTION

Do not use an AC adapter which supplies more than 9 VDC. Higher voltages could cause severe damage to the unit.

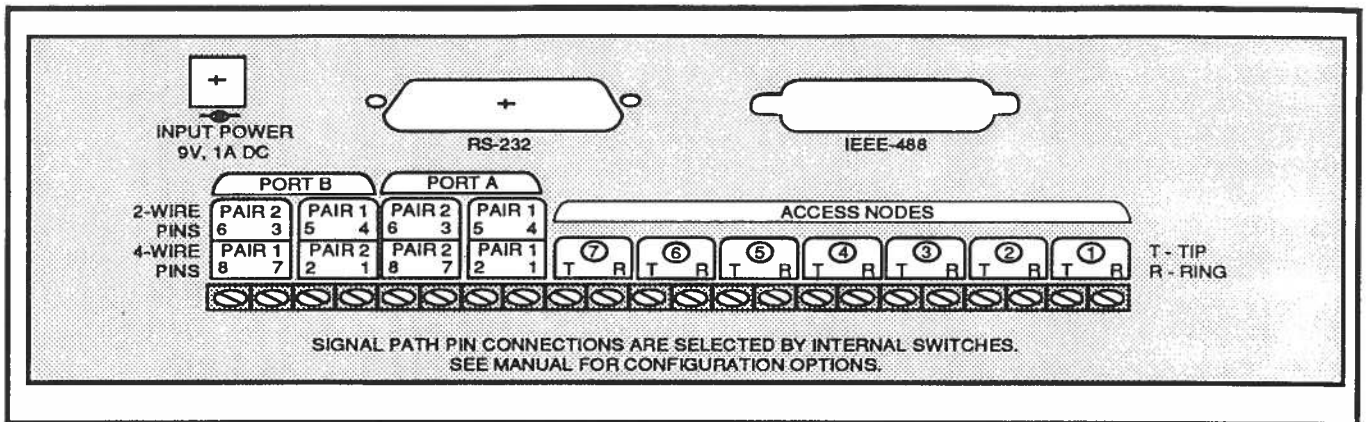

FIGURE 2.7

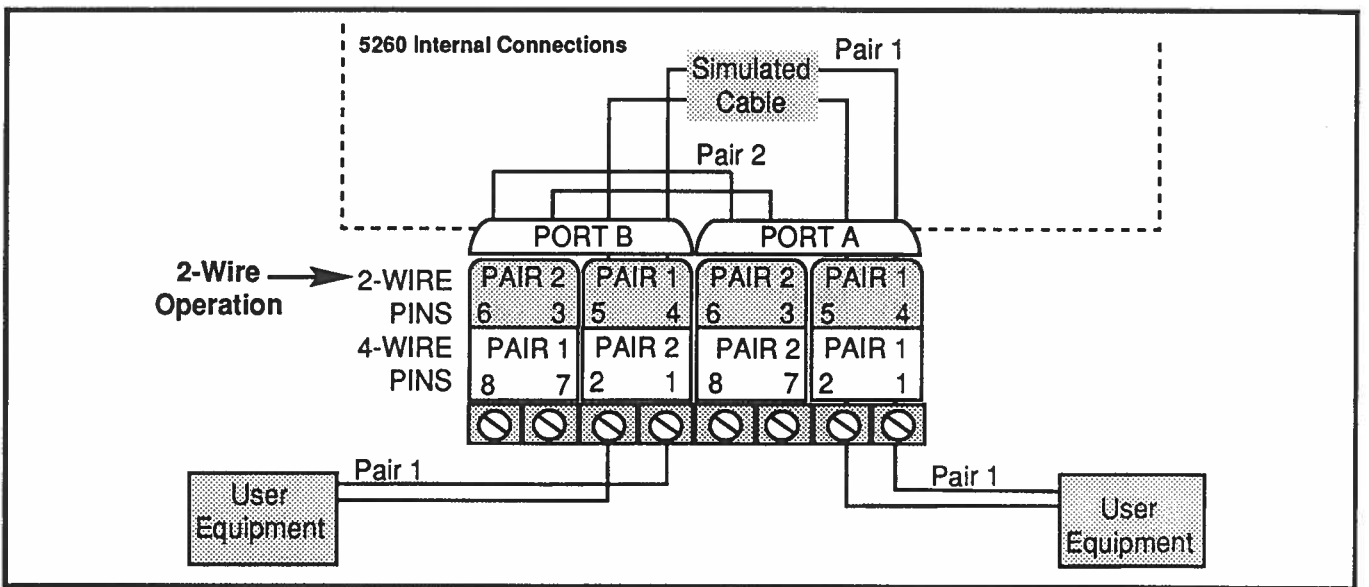

FIGURE 2.8

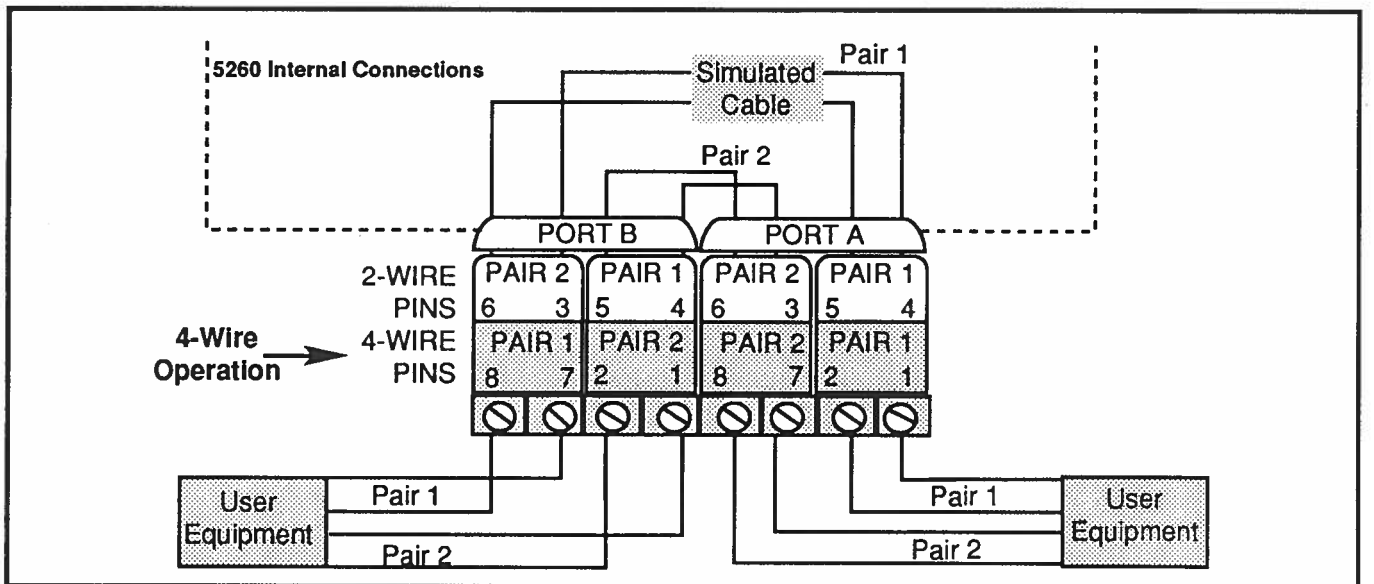

FIGURE 2.9

**SECTION 3
REMOTE CONTROL**

3.0 Introduction2

3.1 Rear Panel RS-232-C Remote Control Option2

3.2 Rear Panel IEEE-488 Remote Control Option2

3.3 Communication Port Setup2

3.3.1 Changing RS-232-C Setup2

3.3.2 Changing IEEE-488 Setup2

 Figure 3.13

3.3.3 Changing RS-232-C and IEEE-488 Option Switches2

3.4 Command Format4

 Table 3.34

3.5 Model 5260 Remote Control Commands5

3.0 INTRODUCTION

In addition to operation from the front panel controls, the Model 5260 may be controlled remotely via an RS-232-C or IEEE-488 interface. The following section describes the controls and commands that are necessary to properly interface with the Model 5260 and provides explanation of messages generated by the simulator.

Note: Remote control is possible only if the unit is equipped with a remote control option card and 9VDC power is supplied.

3.1 REAR PANEL RS-232-C REMOTE CONTROL OPTION

The remote control connector labeled RS-232-C is a standard 25-pin D-type connector for interfacing serial data devices to the Model 5260. A dumb terminal or computer with a standard serial port can control the Model 5260 through this port.

3.2 REAR PANEL IEEE-488 REMOTE CONTROL OPTION

The remote control connector labeled IEEE-488 is a standard 24-pin connector for interfacing parallel type GPIB controllers to the Model 5260. The pin definitions and functionality are specified in *ANSI-IEEE Std. 488-1978* and *IEEE Std. 728-1982*.

3.3 COMMUNICATION PORT SETUP

The Model 5260 remote programming ports use internal dip switches for configuring the setup of the IEEE-488 address and the RS-232-C bit rate, stop bits, and parity. The 5260 is initially configured to an IEEE-488 address of 10 and an RS-232-C format of 9600 bps, 8 data bits, no parity, and 1 stop bit. If any of the settings need changing, the top of the enclosure must be removed and the option card dip switches changed to the desired settings.

3.3.1 Changing the RS-232-C Setup

The RS-232-C format is controlled by the 6-pin dip switch located on the right hand side of the option card, as illustrated in **Figure 3.1**. All the possible formats and the necessary switch settings for each one are also shown in **Figure 3.1**.

3.3.2 Changing the IEEE-488 Setup

The IEEE-488 address is controlled via the 8-pin dip switch closest to the rear of the option card on the right side as illustrated in **Figure 3.1**. There are 31 possible addresses ranging from 0 to 30. Switch settings to obtain the desired address are also shown in **Figure 3.1**.

Note: The dip switch packages are inverted; care should be taken not to confuse the order of the switches.

3.3.3 Changing RS-232-C and IEEE-488 Option Switches

To access the internal dip switches, the top of the enclosure must be removed. The procedure to change dip switch settings is:

1. Remove the four screws on each side of the unit.
2. Remove the screw on the top center of the rear panel.
3. Carefully remove the top cover.
4. Make desired changes to option switch settings.
5. Replace cover.
6. Replace all screws.

3.4 COMMAND FORMAT

All commands sent to the model 5260 using either the IEEE-488 or RS-232-C control ports must be terminated with a Carriage Return (CR). A Line Feed (LF) character after the carriage return is optional. Blanks preceding and following the actual command are allowed, but blanks embedded in the command are not allowed. The backspace key can be used to erase previous entries and reenter the information. An entire line can be deleted using a Control X (^X) key sequence.

Responses from the Model 5260 are terminated with carriage return and line feed characters. For the IEEE-488, the EOI line is asserted when sending the line feed character.

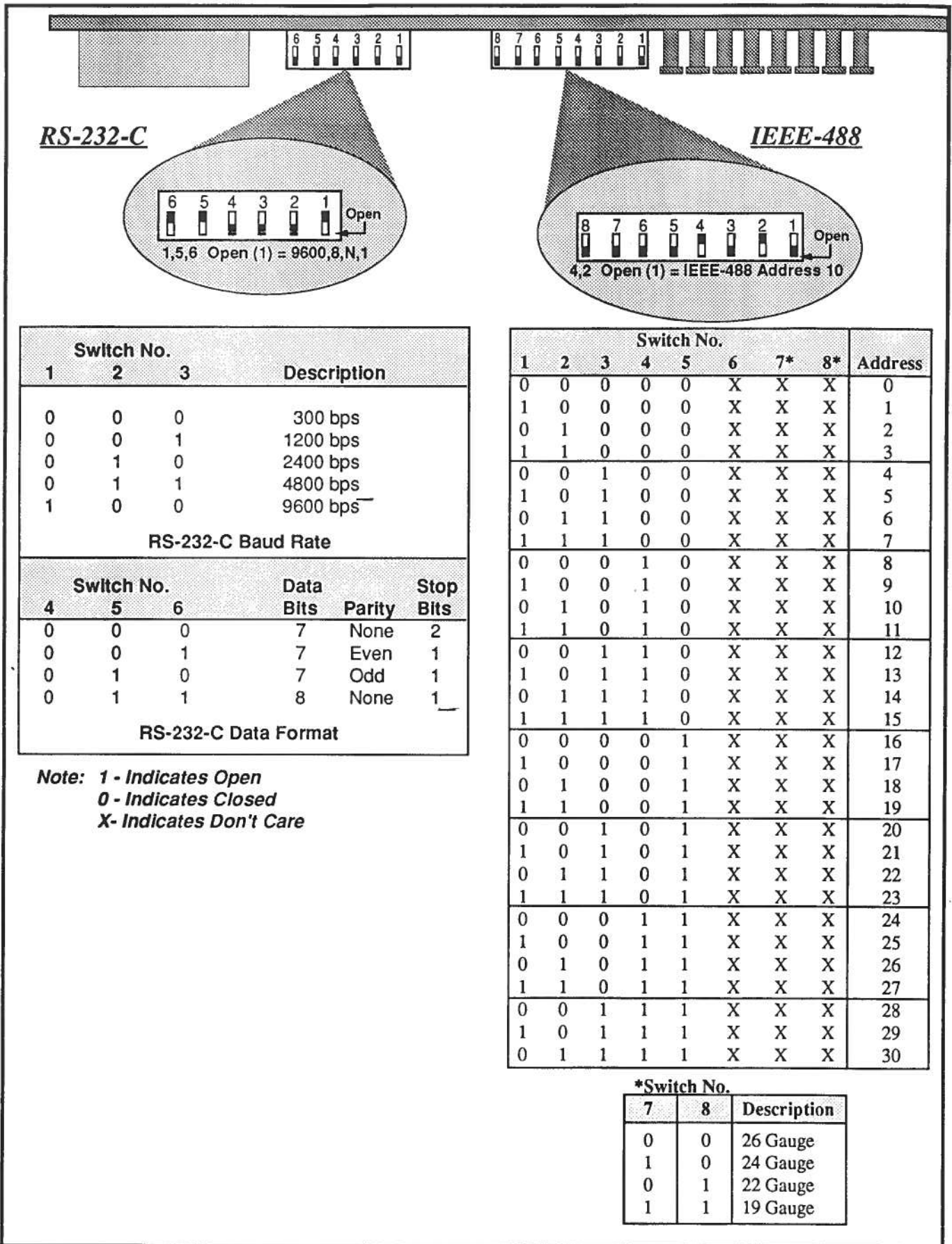

Switch No.			Description
1	2	3	
0	0	0	300 bps
0	0	1	1200 bps
0	1	0	2400 bps
0	1	1	4800 bps
1	0	0	9600 bps

RS-232-C Baud Rate

Switch No.			Data Bits	Parity	Stop Bits
4	5	6			
0	0	0	7	None	2
0	0	1	7	Even	1
0	1	0	7	Odd	1
0	1	1	8	None	1

RS-232-C Data Format

Note: 1 - Indicates Open
 0 - Indicates Closed
 X - Indicates Don't Care

Switch No.								Address
1	2	3	4	5	6	7*	8*	
0	0	0	0	0	X	X	X	0
1	0	0	0	0	X	X	X	1
0	1	0	0	0	X	X	X	2
1	1	0	0	0	X	X	X	3
0	0	1	0	0	X	X	X	4
1	0	1	0	0	X	X	X	5
0	1	1	0	0	X	X	X	6
1	1	1	0	0	X	X	X	7
0	0	0	1	0	X	X	X	8
1	0	0	1	0	X	X	X	9
0	1	0	1	0	X	X	X	10
1	1	0	1	0	X	X	X	11
0	0	1	1	0	X	X	X	12
1	0	1	1	0	X	X	X	13
0	1	1	1	0	X	X	X	14
1	1	1	1	0	X	X	X	15
0	0	0	0	1	X	X	X	16
1	0	0	0	1	X	X	X	17
0	1	0	0	1	X	X	X	18
1	1	0	0	1	X	X	X	19
0	0	1	0	1	X	X	X	20
1	0	1	0	1	X	X	X	21
0	1	1	0	1	X	X	X	22
1	1	1	0	1	X	X	X	23
0	0	0	1	1	X	X	X	24
1	0	0	1	1	X	X	X	25
0	1	0	1	1	X	X	X	26
1	1	0	1	1	X	X	X	27
0	0	1	1	1	X	X	X	28
1	0	1	1	1	X	X	X	29
0	1	1	1	1	X	X	X	30

*Switch No.		
7	8	Description
0	0	26 Gauge
1	0	24 Gauge
0	1	22 Gauge
1	1	19 Gauge

FIGURE 3.1

The Model 5260 can be configured via IEEE-488 or RS-232-C according to the commands summarized below. The following conventions are followed when interpreting the commands:

- Xx** - Argument
- []** - Optional argument. If the argument is omitted, the 5260 will return to the present argument value. Brackets should not be included in the command.

The Model 5260 will reconfigure the hardware according to the command given, and respond as follows:

- OK** - The command has been accepted and implemented.
- ERR x** - Error message. Refer to **Table 3.3, Command Responses.**

TABLE 3.3 Command Response, Error Messages ERRX

X	Description
3	Argument Out of Range
4	Invalid Command

The Model 5260 supports serial polling during IEEE-488 operation. After a command has been sent, the 5260 processes the command and asserts the Serial Request (SRQ) line. At this point, the controller should send the Serial Poll Enable (SPE) message and poll the device for a status response. This response will be **40 HEX**. The controller may then send the SPD message and read the Model 5260 data.

CAUTION

The command arguments must be sent to the Model 5260 in exactly the form shown in the command summary. Otherwise, an invalid argument response will be returned. Brackets [] indicate optional arguments and should not be included in the command.

3.5 MODEL 5260 REMOTE CONTROL COMMANDS

COMMAND		SUMMARY
GAUGE	Description:	Query for the 5260 wire gauge
	Arguments:	None
	Response:	XX; where XX is the American wire gauge
MANUAL	Description:	Return the unit to its initial state to allow manual control.
	Arguments:	None
	Response:	OK or ERR code
MODE[,X1]	Description:	Set unit to 2-Wire or 4-Wire operation.
	Arguments:	X1 = 2W X1 = 4W
	Response:	OK or ERR code
MODE	Response:	5260 provides present value(s)
VERSION	Description:	Query for the 5260 Software Version
	Arguments:	None
	Response:	#.XX; where # is the Software Release Number, and XX is the Software Revision.
WIRE[,X1]	Description:	Configure unit to a length of X1.
	Arguments:	X1 = 0 - 20 kFt at 300 kHz bandwidth Step = 0.5 kFt X1 = 0 - 60 kFt at 100 kHz bandwidth Step = 0.5 kFt
	Response:	OK or ERR code
WIRE	Response:	5260 provides present value(s)

**SECTION 4
MAINTENANCE**

4.0 Replacing Signal Path Fuses2

4.0 REPLACING SIGNAL PATH FUSES

The Pair 1 and Pair 2 signal paths are fused to protect internal circuitry. If at any time the signal path through the box is lost, these fuses should be checked and replaced as necessary. To check and/or replace the fuses, follow these steps:

1. Remove the power transformer (if used) from the AC outlet.
2. Remove the top cover by removing the four screws on either side of the unit, as well as the screw located at the top center of the rear panel.
3. Locate the signal path fuses. There will be either two or three fuses located toward the front of the unit. The quantity depends on the particular revision of the Model 5260 being used.
4. Remove each fuse from the socket by pulling up firmly on the fuse body.
5. Check each fuse using an ohm meter, and replace any blown fuses.
6. Replace top cover and secure.

SECTION 5
TECHNICAL REFERENCE

5.0 Model 5260 Specifications.....2

5.1 Connector Specifications.....2

5.1.1 Port A and Port B Front Panel RJ-45S2

5.1.2 Port A and Port B Bantam Jacks2

5.1.3 Rear Panel Terminal Strip2

5.2 Remote Option Card Connectors.....2

5.2.1 IEEE-488 Remote Control Connector2

5.2.2 RS-232-C Remote Control Connector.....2

5.0 MODEL 5260 SPECIFICATIONS

General Specifications

- Operational Modes:**
 - 2-Wire
 - 4-Wire (see note, Section 2, page 2)
- Operating Temperature:**
 - 0 to 40°C
- Size:**
 - 3.5"H x 10"W x 11.75"D
- Weight:**
 - 5 lbs. (without option card)
 - 6 lbs. (with option card)
- Maximum Applied Loop Current:**
 - 120 mA (fused)
- Maximum Applied Loop Voltage:**
 - 300 volts, overvoltage protected
- System Control Modes:**
 - Manual Front Panel
 - Remote RS-232-C Interface (Option Card Only)
 - Remote IEEE-488 Interface (Option Card Only)

Wire Simulator Card Specifications

- Gauges:**
 - 19,22,24,26 AWG available
 - PIC Cable @ 25°C
- Maximum Length:**
 - 20,000 feet at 100 kHz
 - 60,000 feet at 300 kHz
- Resolution:**
 - 500 Ft.
- Amplitude Accuracy:**
 - 22, 24, 26 ± 0.5 dB ± 5% to 80 dB Attenuation
 - 19 AWG ± 1 dB ± 10% to 80 dB Attenuation

Control Port Interfaces

- IEEE-488 (GPIB) Interface Connector:**
 - 24-pin female
- RS-232-C Serial Port:**
 - 25-pin female "D"

5.1 CONNECTOR SPECIFICATIONS

The following connector pin assignments and electrical specifications are presented for reference.

5.1.1 Port A and Port B front Panel RJ-45S

- Manufacturing Part Number: RJ-45S
- Mating Connector Part Number: Std. 8-pin plug
- Number of Pins: 8

Pin Definition:

Pin #	Function
1	See Section 2.3.1, Option Switches
2	See Section 2.3.1, Option Switches
3	Pair 2 - RING
4	Pair 1 - RING
5	Pair 1 - TIP
6	Pair 2 - TIP
7	See Section 2.3.1, Option Switches
8	See Section 2.3.1, Option Switches

5.1.2 Port A and Port B Bantam Jacks

- Manufacturing Part Number: ADC PJ-889
- Mating Connector Part Number: Std. Bantam plug
- Conductors: Tip, Ring, Chassis Ground

5.1.3 Rear Panel Terminal Strip

- Manufacturing Part Number: Augat 4DB-R102-22
- Number of Pins: 22

5.2 REMOTE OPTION CARD CONNECTORS

These are specifications on the connectors supplied with the option card.

5.2.1 IEEE-488 Remote Control Connector

- Manufacturing Part Number: 3M 3549-1000
- Mating Connector Part Number: 3M 3548-1000
- Number of Pins: 24

5.2.2 RS-232-C Remote Control Connector

- Manufacturing Part Number: 3M 8325-6000
- Mating Connector Part Number: 3M 3225-6000
- Number of Pins: 25