

T400 DDS PWR LR 56/72 AND DDST LP POWERING UNIT INSTALLATION AND MAINTENANCE

CONTENTS

1. General	1
2. Installation	2
3. Connectors	2
4. Maintenance	2
5. Warranty and Customer Service	2

FIGURES

Figure 1. ADTRAN T400 DDS PWR	1
Figure 2. Option Switch	2
Figure 3. Connector Pin Assignments	2

1. GENERAL

1.1 This section provides installation and maintenance information for the ADTRAN T400 DDS PWR unit. **Figure 1** is a photograph of the unit.

1.2 Issue 2 of this practice contained text revisions. Issue 3 contains additions to subsection 1.4.

1.3 The T400 DDS PWR unit acts as an interface between a standard OCU or OCU DP, and a remote LR 56/72 DDS Repeater or DDST LP Digital Data System Termination unit. The T400 DDS PWR unit allows data to pass through uncorrupted, but adds the appropriate power required to run the remote unit.

1.4 Basic features of the T400 DDS PWR unit include:

- Indication of sealing current reversal from the OCU or OCU DP. The yellow LOOPBACK indicator will illuminate upon detection of current reversal and will maintain the reversed current condition toward the remote unit.
- Indication of the absence of sealing current toward the remote unit. The yellow NO SX indicator will illuminate in an open circuit condition.
- Selection of three powering modes:

V - Constant -130 V output: used when powering a DDST LP.



Figure 1. ADTRAN T400 DDS PWR

C - Constant 43 mA output: used when powering an LR 56/72 or LR 9.6/72.

N - Normal sealing current mode (4 mA - 20 mA): used when loop powering is not required.

Note: In this mode, normal sealing current resistors are connected to the loop in place of the power supply outputs. However, -130 V is still generated on the unit.

- Indication of abnormal conditions in the circuit. The red FAULT indicator will illuminate if the unit has been improperly optioned for voltage or current mode; or if a short circuit condition or excessive resistance condition exists in the circuit.

Note: The FAULT LED does not operate in the N powering mode.

- Supports loop lengths up to 45 dB in all powering modes and at all rates except 2.4 kbps. At 2.4 kbps and 2.4 SC, loop lengths up to 34 dB are supported.

2. INSTALLATION

2.1 After unpacking the unit, immediately inspect it for possible shipping damage. If damage is discovered, file a claim immediately with the carrier and then contact ADTRAN customer service.

2.2 The power selection option must be set before installation. A label on the unit indicates the proper power mode depending on the type of unit to be powered, as illustrated in **Figure 2**.

2.3 The T400 DDS PWR unit plugs directly into any slot of a standard T400 shelf.

Note: Lightning and powercross protection is only provided from the T400 DDS PWR unit to the remotely powered unit (loop side). It is intended for use in protected environments, such as the central office.

3. CONNECTORS

3.1 Connector pin assignments for the T400 DDS PWR unit are illustrated in **Figure 3**. All connections to the unit are made via the backplane. No additional backplane wiring is necessary for normal operation.

3.1 Connector pin assignments for the T400 DDS PWR unit are illustrated in **Figure 3**. All connections to the unit are made via the backplane. No additional backplane wiring is necessary for normal operation.

4. MAINTENANCE

4.1 The DDS PWR unit requires no routine maintenance to operate properly. ADTRAN does not recommend repairs be performed in the field. Repair service may be obtained by returning the defective unit to ADTRAN.

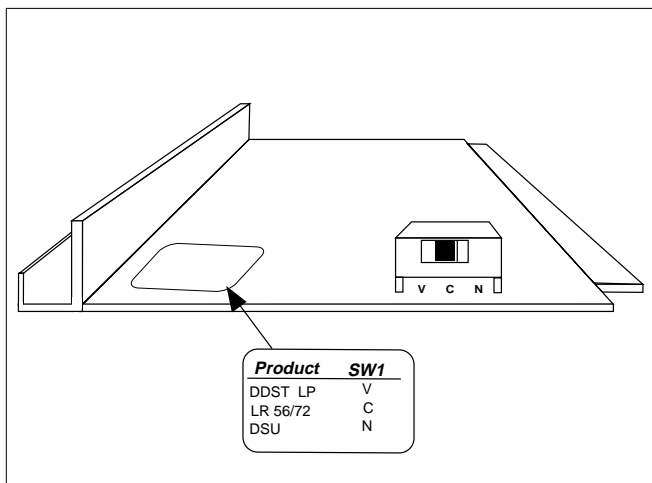

Figure 2. Option Switch

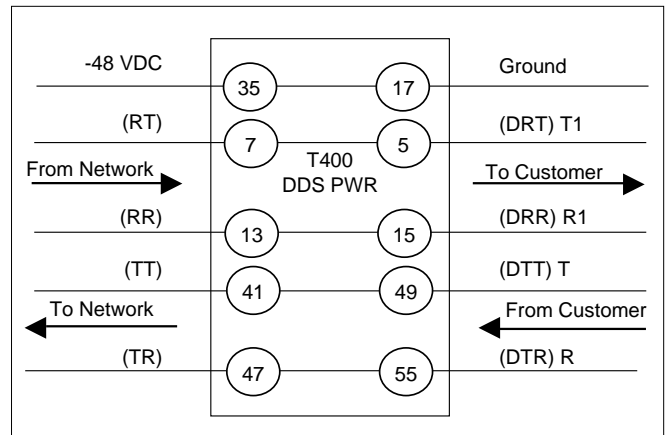

Figure 3. Connector Pin Assignments

5. WARRANTY AND CUSTOMER SERVICE

ADTRAN will replace or repair this product within five (5) years from the date of shipment, if the product does not meet its published specifications, or if it fails while in service. For detailed warranty, repair, and return information, refer to ADTRAN's Equipment Warranty and Repair and Return Policy Procedure.

5.1 Return Material Authorization (RMA) is required prior to returning equipment to ADTRAN.

5.2 For service, RMA requests, or further information, contact one of the following.

ADTRAN Customer Service:

RMA	(205) 971-8722
Technical Support	(800) 726-8663
Application Engineering	(800) 615-1176
Sales	(800) 827-0807

Repair and Return Address:

ADTRAN, Inc.
Customer Service Department
901 Explorer Boulevard
Huntsville, Alabama 35806-2807

